

SHARP SERVICE MANUAL

SERVICE-ANLEITUNG

维修手册

S06S3VLDC1EHS

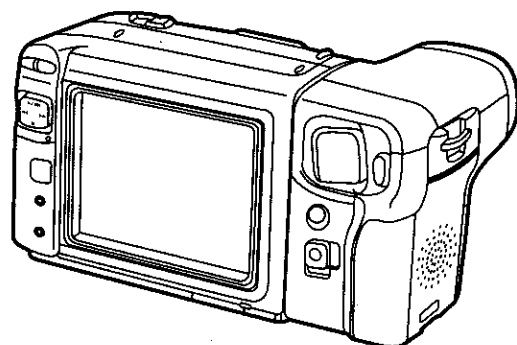

LIQUID CRYSTAL DIGITAL VIDEO CAMERA
DIGITALE VIDEO-KAMERA MIT FLÖSSIGKRISTALL-ANZEIGE
数值式液晶屏录像摄影机

Mini DV **SHARP**
VIEWCAM

MODELS
MODELLE
型号

VL-DC1E/H/S

In the interests of user-safety (Required by safety regulations in some countries) the set should be restored to its original condition and only parts identical to those specified should be used.

Im Interesse der Benutzersicherheit (erforderliche Sicherheitsregeln in einigen Ländern) muß das Gerät in seinen Originalzustand gebracht werden. Außerdem dürfen für die spezifizierten Bauteile nur identische Teile verwendet werden.

为了用户安全起见(根据一些国家的安全规程的需要), 应将液晶投影机保持于最初的状态, 而且只能使用与指定物相同的部件。

CONTENS

	Page		Page
1. SPECIFICATIONS	3	13. OVERALL WIRING DIAGRAM	193
2. PARTS NAMES	4	14. HEAD AMPLIFIER CIRCUIT SCHEMATIC DIAGRAM	195
3. DISASSEMBLING THE SET	7	15. CAM CCD CIRCUIT SCHEMATIC DIAGRAM	197
4. MECHANISM ADJUSTMENT JIGS AND PARTS	13	16. CAMERA CIRCUIT SCHEMATIC DIAGRAM	199
5. INSPECTION AND MAINTENANCE ITEMS AND INTERVALS	15	17. VCR-1 CIRCUIT SCHEMATIC DIAGRAM	213
6. MECHANICAL ADJUSTMENTS AND CHECKS	17	18. VCR-2 CIRCUIT SCHEMATIC DIAGRAM	231
7. TAPE RUNNING ADJUSTMENT	22	19. MICROPHONE AMP. CIRCUIT SCHEMATIC DIAGRAM	251
8. MECHANICAL SECTION ASSEMBLY AND PARTS REPLACEMENT (DISASSEMBLY AND REASSEMBLY)	25	20. PRINTED WIRING BOARD ASSEMBLIES	253
9. ADJUSTING ELECTRICAL CIRCUIT	37	21. SEMICONDUCTOR SHAPES	267
10. USEFUL TIPS	59	22. PARTS LIST	269
11. SIGNAL FLOW DIAGRAM	177	23. PACKING OF THE SET	300
12. BLOCK DIAGRAM	182		

INHALT

	Seite		Seite
1. TECHNISCHE DATEN	61	13. GESAMT-STROMLAUFPLAN	193
2. BEZEICHNUNG DER TEILE	62	14. STROMLAUFPLAN DES VORVERSTÄRKER-SCHALTKREISES	195
3. ZERLEGEN DES GERÄTS	65	15. STROMLAUFPLAN DES CAM CCD-SCHALTKREISES	197
4. HILFSVORRICHTUNGEN UND TEILE ZUR EINSTELLUNG DER MECHANISMUS	71	16. STROMLAUFPLAN DES KAMERA-SCHALTKREISES	199
5. TEILE UND ZEITABSTÄNDE FÜR ÜBERPRÜFUNG UND WARTUNG	73	17. STROMLAUFPLAN DES VCR-1-SCHALTKREISES	213
6. MECHANISCHE EINSTELLUNGEN UND ÜBERPRÜFUNGEN	75	18. STROMLAUFPLAN DES VCR-2-SCHALTKREISES	231
7. BANDLAUFEINSTELLUNG	80	19. STROMLAUFPLAN DES MIKROFON-VERSTÄRKERSCHALTKREISES	251
8. MECHANISCHER ABSCHNITT UND ERSETZEN VON TEILEN (ZERLEGUNG UND ZUSAMMENBAU)	83	20. PLATINEN-EINHEITEN	253
9. EINSTELLUNG DER ELEKTRISCHEN SCHALTKREISE	95	21. HALBLEITERFORMEN	267
10. NÜTZLICHE HINWEISE	117	22. TEILELISTE	269
11. SIGNALFLUSSDIAGRAMM	177	23. VERPACKUNG DES GERÄTS	300
12. BLOCKDIAGRAMM	182		

目 录

	页数		页数
1. 规格参数	119	14. 摄影机放大器电路原理图	195
2. 各部位名称	120	15. CAM CCD电路原理图	197
3. 录像摄影机的分解	123	16. 摄影机电路原理图	199
4. 机械调整用工具	129	17. 录像机-1电路原理图	213
5. 定期检查和保养的项目及其期间	131	18. 录像机-2电路原理图	231
6. 机械的检查和调整	133	19. 麦克风放大器电路原理图	251
7. 走带状况的调整	137	20. 各印刷电路板的组装件	253
8. 机械部分组件与零件的更换(拆卸与重装)	141	21. 半导体引脚的识别	267
9. 电路的调整	153	22. 零件表	269
10. 问题的处理措施	175	23. 包装方法	300
11. 信号流程图	177		
12. 方框图	182		
13. 整体电路方框图	193		

1. SPECIFICATIONS

Signal System: PAL standard
 Recording System: 2 rotary heads, helical scanning system
 Cassette: Digital VCR Mini DV video cassette
 Recording/Playback Time: 60 minutes (DVM60)
 Tape Speed: 18.831 mm/second
 Pickup Device: 1/4" (6.4 mm, effective size: 4.5 mm) CCD image sensor (with approx. 470,000 pixels including optical black)
 Lens: 12 × power zoom lens (F1.8, f = 4.2–50.4 mm), full-range auto focus
 Lens Filter Diameter: 37 mm
 Monitor: 4" (10.1 cm)—full-colour LCD screen (TFT active matrix)
 Microphone: Electret stereo microphone
 Colour Temperature Compensation: Auto white balance with white balance lock
 Minimum Illumination: 6 lux* (with gain-up, and digital zoom off)
 Video Output Level: 1.0 Vp-p 75-ohm unbalanced
 Audio Output Level: –8 dBs, impedance less than 2.2 kohms
 Speaker Output: 300 mW
 External Microphone Input: 3.5 mm diameter mini-plug, –66 dBs, output impedance 6.8 kohms, DC 4 V, for plug-in-power microphone use
 Power Requirement: DC 3.6 V
 Power Consumption: 8.5 W (during camera recording in full auto mode with zoom motor off, backlight in normal mode)
 Operating Temperature: 0°C to +40°C
 Operating Humidity: 30% to 80%
 Storage Temperature: –20°C to +60°C
 Dimensions (approx.): 181 mm (W) × 99 mm (H) × 88 mm (D)
 Weight (approx.): 690 g (without battery pack, lithium battery, video cassette)

AC Adaptor/Battery Charger

Power Requirement: AC 110-240 V, 50/60 Hz
 DC Output: 4.5 V
 Power Consumption: 25 W
 Dimensions (approx.): 120 mm (W) × 51 mm × (H)101.5 mm (D)

VL-DC1E:
 Weight (approx.): For Asia/Middle East (UADP-0233TAZZ): 394g
 For Hong Kong (UADP-0219TAZZ): 460g
 For Australia/New Zealand (UADP-0216TAZZ): 420g
 For Russia (UADP-0235TAZZ): 394g

VL-DC1H:
 Weight (approx.): (UADP-0215TAZZ): 460g

VL-DC1S:
 Weight (approx.): (UADP-0214TAZZ): 380g

Specifications are subject to change without notice.

*Minimum illumination: Since there is no widely accepted testing procedure for determining minimum illumination capability, lux ratings are comparable only between models from the same manufacturer.

2. PART NAMES

For details on the use of each control, refer to the page number indicated in the brackets.

Front view

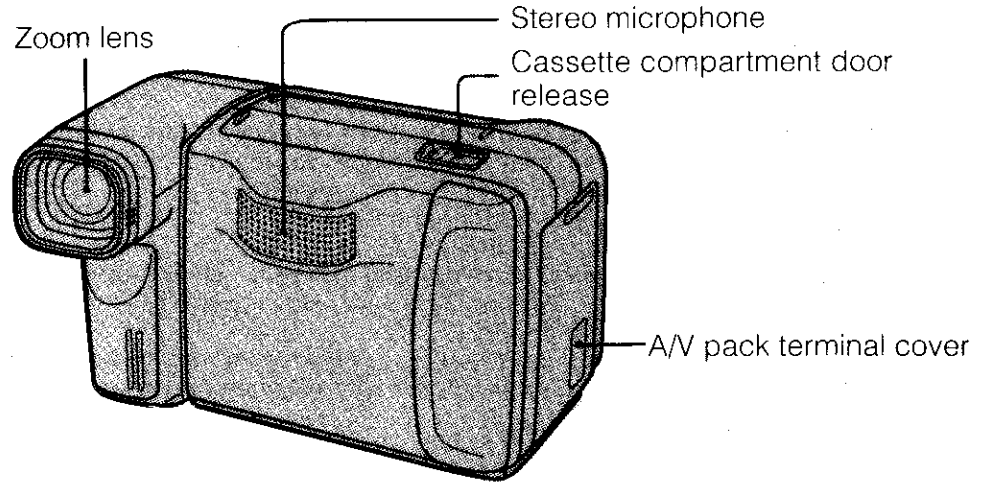

When the cassette compartment door is opened

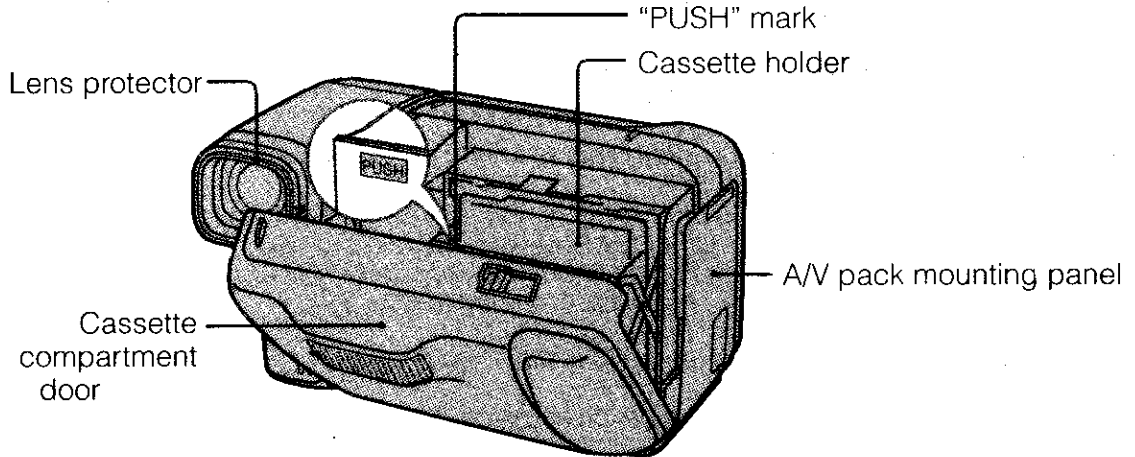

Removing the Lens Protector

Before mounting the optional wide or telephoto conversion lens, remove the lens protector by turning it anticlockwise.

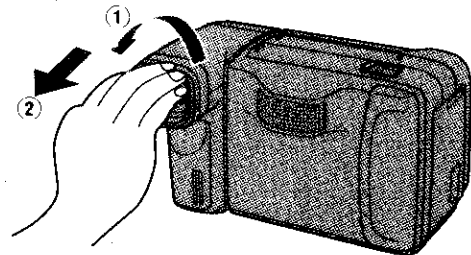

Rear view

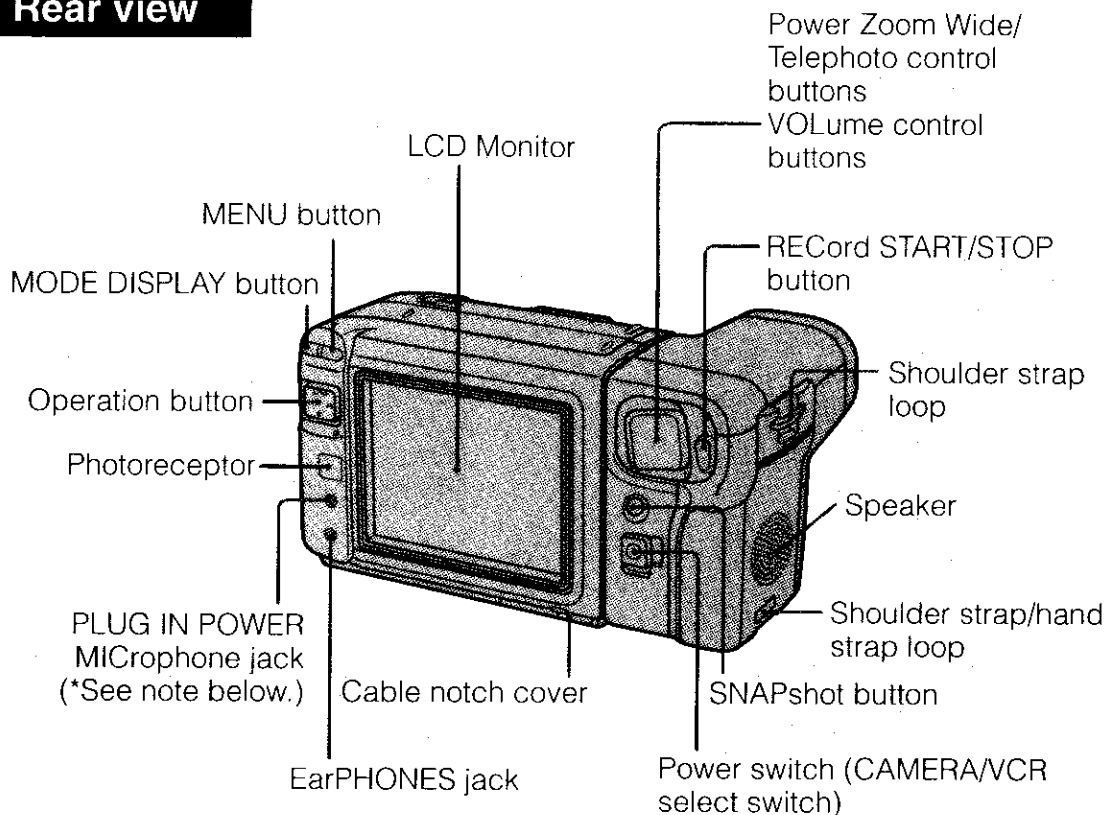

***About the PLUG IN POWER MIC Jack**

This external microphone jack outputs a DC voltage of 4.0 V. It is for use with the microphone supplied with the sports case optional accessory for this VIEWCAM, or with any 2.5-4.0 volt DC use condenser-type microphone with a 3.5 mm diameter plug. The use of other types of microphones may result in damage to the microphone or the VIEWCAM.

Side view

When camera module is rotated

Fluorescent lamp compartment

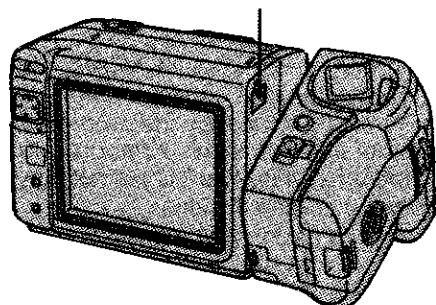

Bottom view

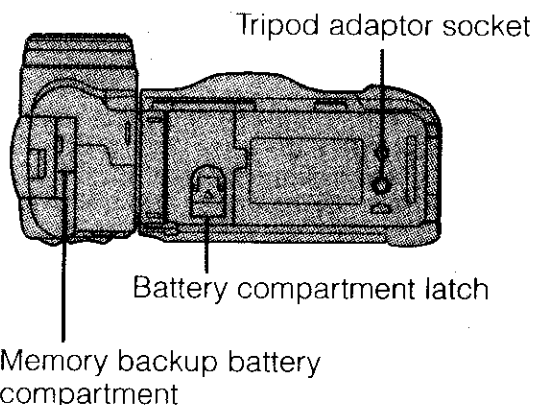

FLUORESCENT LAMP BACKLIGHT

The fluorescent lamp backlight used in this VIEWCAM will eventually need replacing. If you continue to use the VIEWCAM when the fluorescent lamp has almost reached the end of its service life, the "REPLACE THE LAMP." indicator will be displayed on the monitor for approximately one minute. When this occurs, purchase a replacement lamp (KLMPV0018TAZZ) from your dealer or a SHARP Full Line Parts Distributor, and replace the old lamp.

REPLACE THE LAMP.

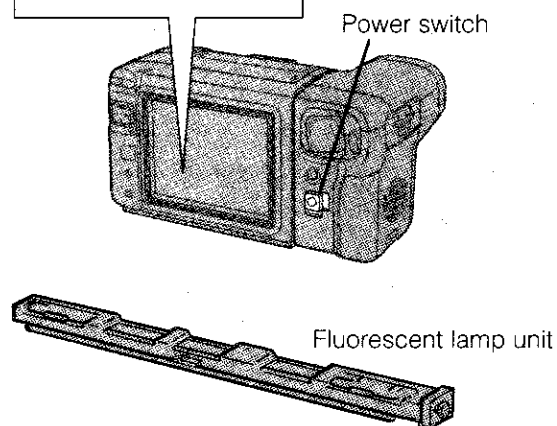

Replacing the Fluorescent Lamp Backlight

- 1** Set the Power switch to OFF to turn off the VIEWCAM, and wait about 15 minutes for the lamp unit to cool down.

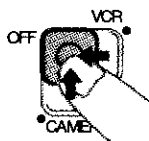

- 2** Rotate the camera module of the VIEWCAM halfway forward as shown.

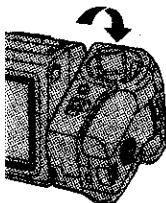

- 3** Remove the lamp compartment cover: insert a pointed object such as the point of a pen into the opening above the cover, push the cover release "L" down, and then pull off the cover.

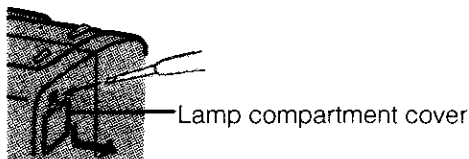

- 4** Carefully hold the end (white knob) of the lamp unit with tweezers, and pull it out.

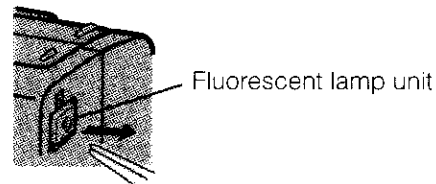

- 5** Insert the replacement lamp unit into the compartment. See note below.

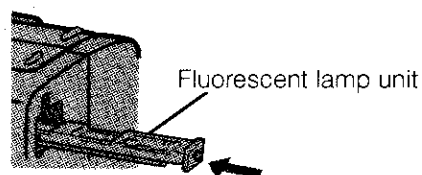

- 6** Replace the fluorescent lamp compartment cover.

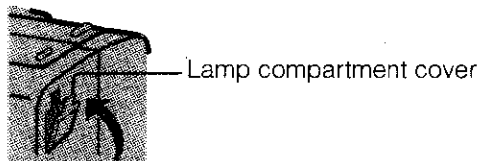

Notes:

- In step 5 above, be sure to insert the replacement fluorescent lamp straight in, in the direction of the arrow, into the compartment. Do not press diagonally as it may cause contact failure.
- The fluorescent light may flicker when first turned on. Should this occur, turn off the VIEWCAM, and then turn it on again.
- When used in cold locations, the fluorescent lamp may lose some of its brightness.
- Remove the battery pack before replacing the fluorescent lamp.

Caution:

- The fluorescent lamp is hot during and immediately after use of the VIEWCAM. Wait at least 15 minutes after turning the power off before attempting to change the lamp, to allow time for it to cool down. Attempting to change the lamp unit while it is still hot may result in burns or other injuries.

3. DISASSEMBLING THE SET

3-1. Removing the camera unit

Caution: Before detaching the covers, be sure to turn off the power and make sure that there is no battery inside.

1) Remove the four screws and detach the camera's front cover.

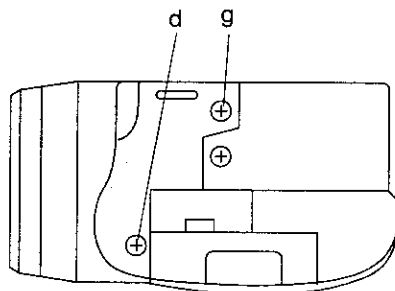
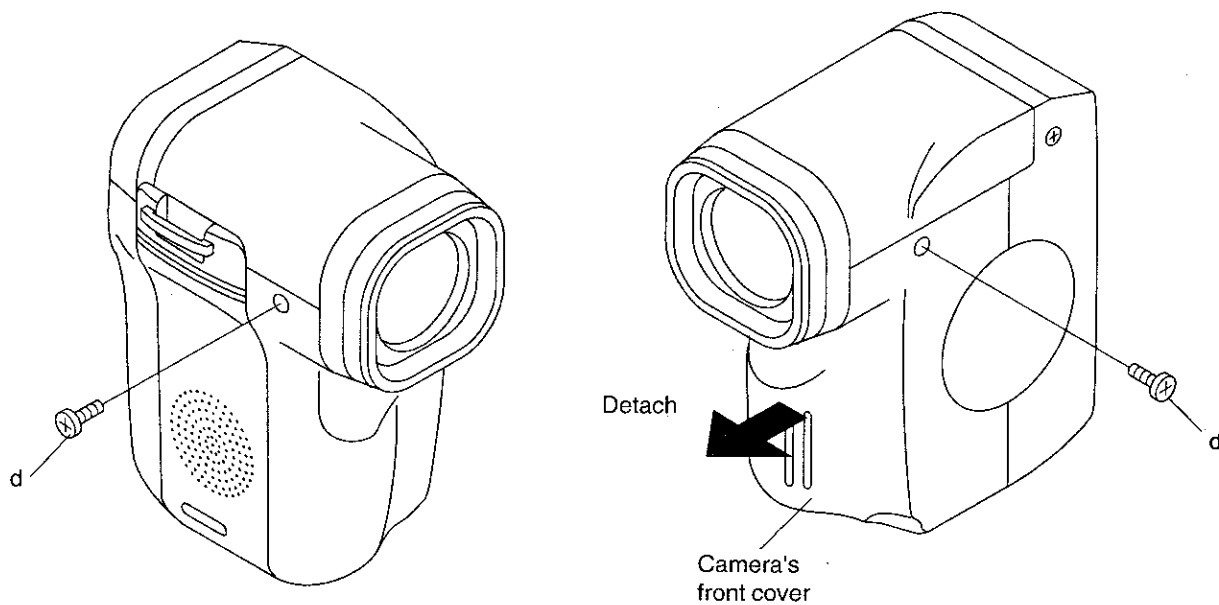

2) Disconnect the lower connector.

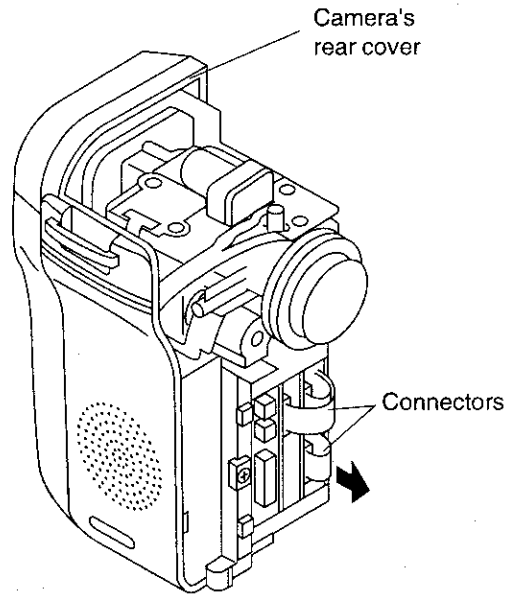

3) Remove the three screws and detach the camera's rear cover.

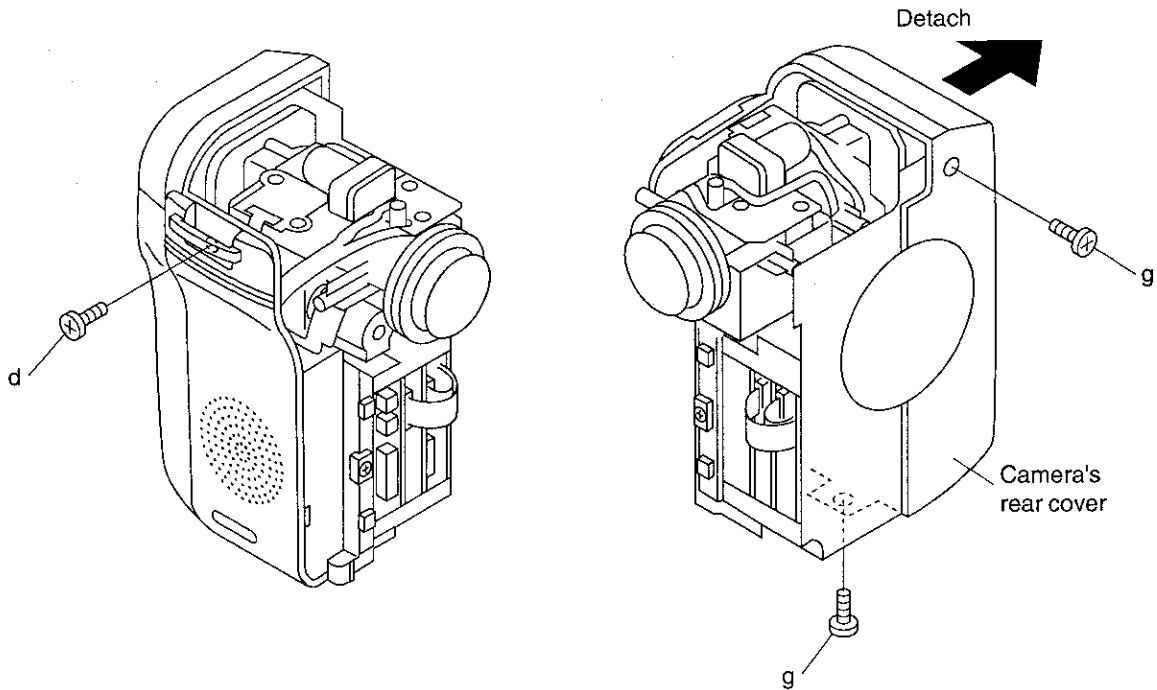

- 4) Disconnect the upper connector and the four screws.
Detach the side cover off the tilt frame C.

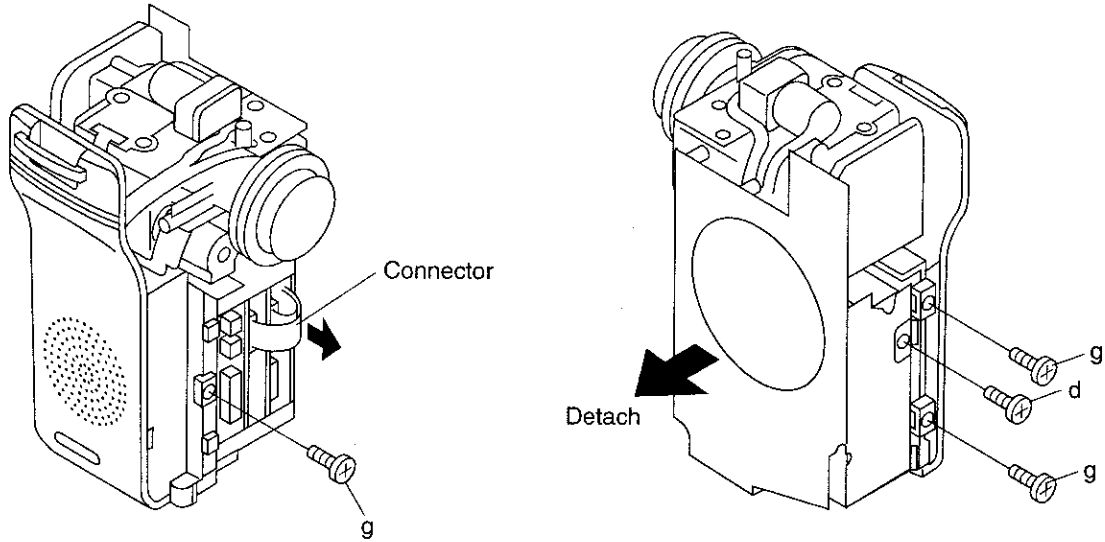

- 5) Remove the two screws, and take out the camera PWB unit and the lens unit together.

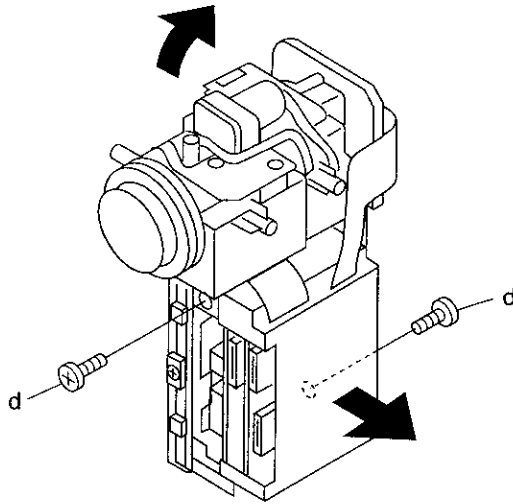

3-2. Disassembling the body

3-2-1. Removing the bottom cover

- 1) Remove the four screws and take the bottom cover assembly out of the body.

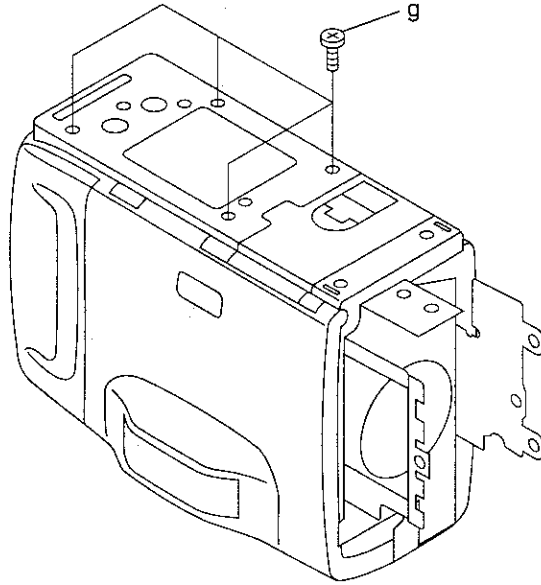

3-2-2. Removing the cabinet L

- 1) Remove the four screws, disconnect the connector, and open the VCR cover and the battery cover. Now detach the tilt cover.

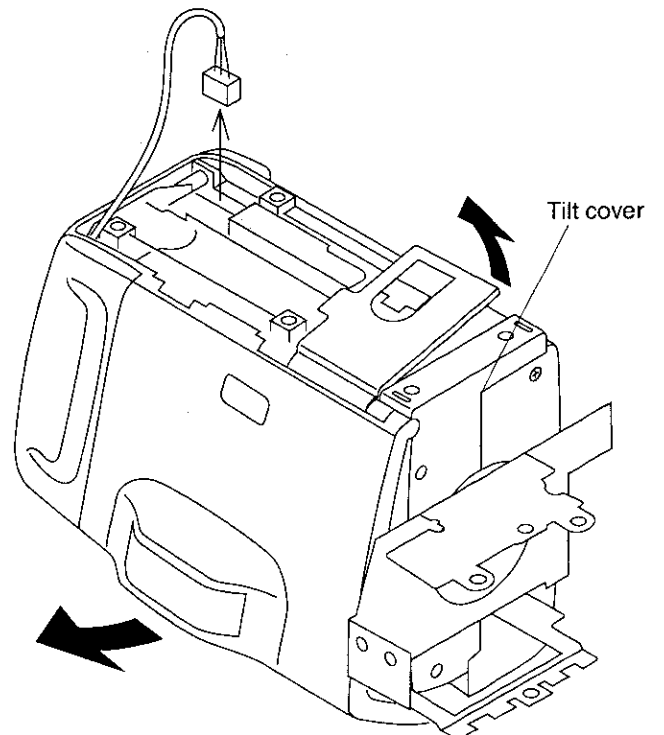
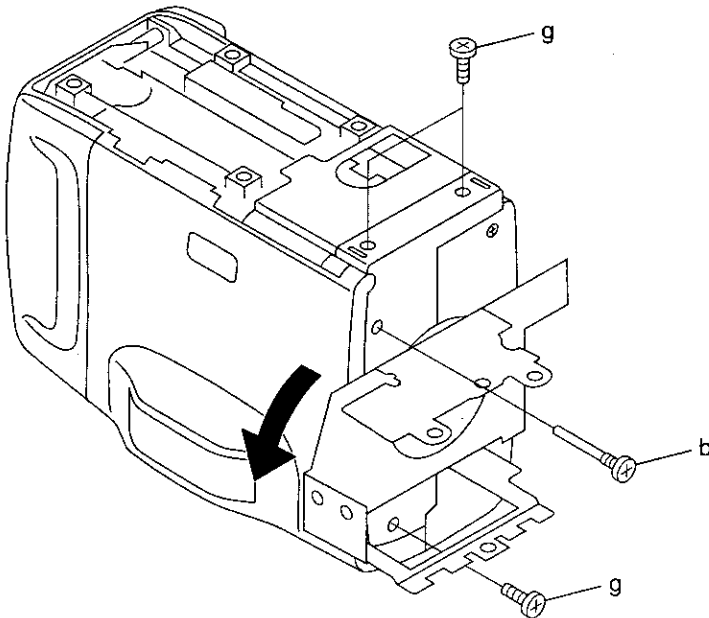

2) Remove the five screws and detach the cabinet L.

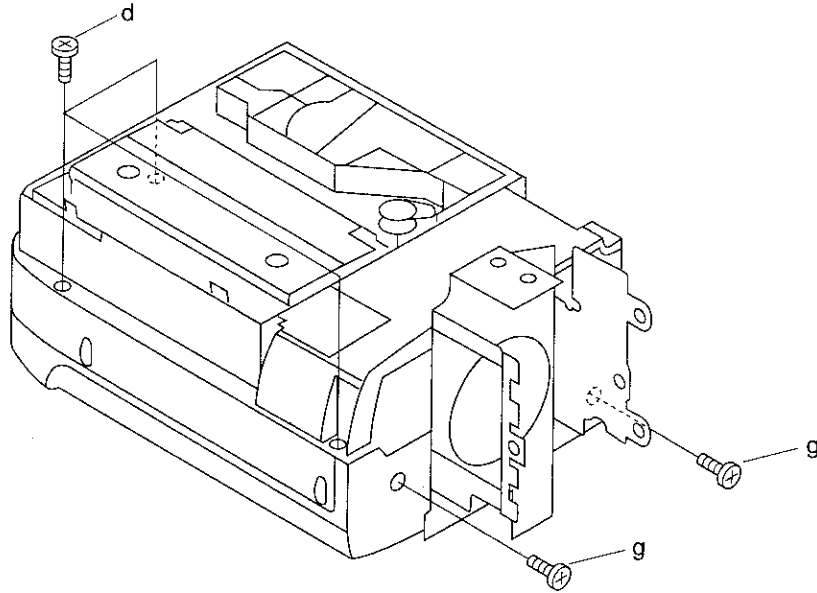

3) Detach the part A, remove the three screws, and disconnect the flexible cable connector. The LCD unit can now be taken out.

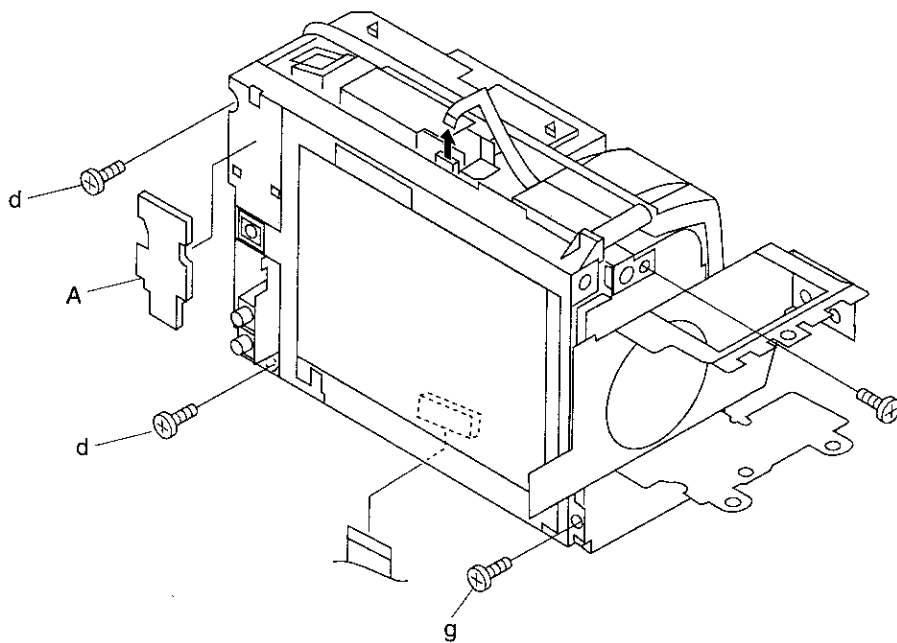

Removing the LCD unit

1. Draw the flurescent lamp unit out of the LCD holder.
2. Remove the two screws (LX-HZ0031TAFF) and detach the lamp shield plate.
3. Remove the screw (LX-HZ0031TAFF) and detach the inverter unit.
4. Remove the screw (LX-HZ0031TAFF) and detach the light guide set spring.
5. Finally detach all the sheets and plate off the holder.

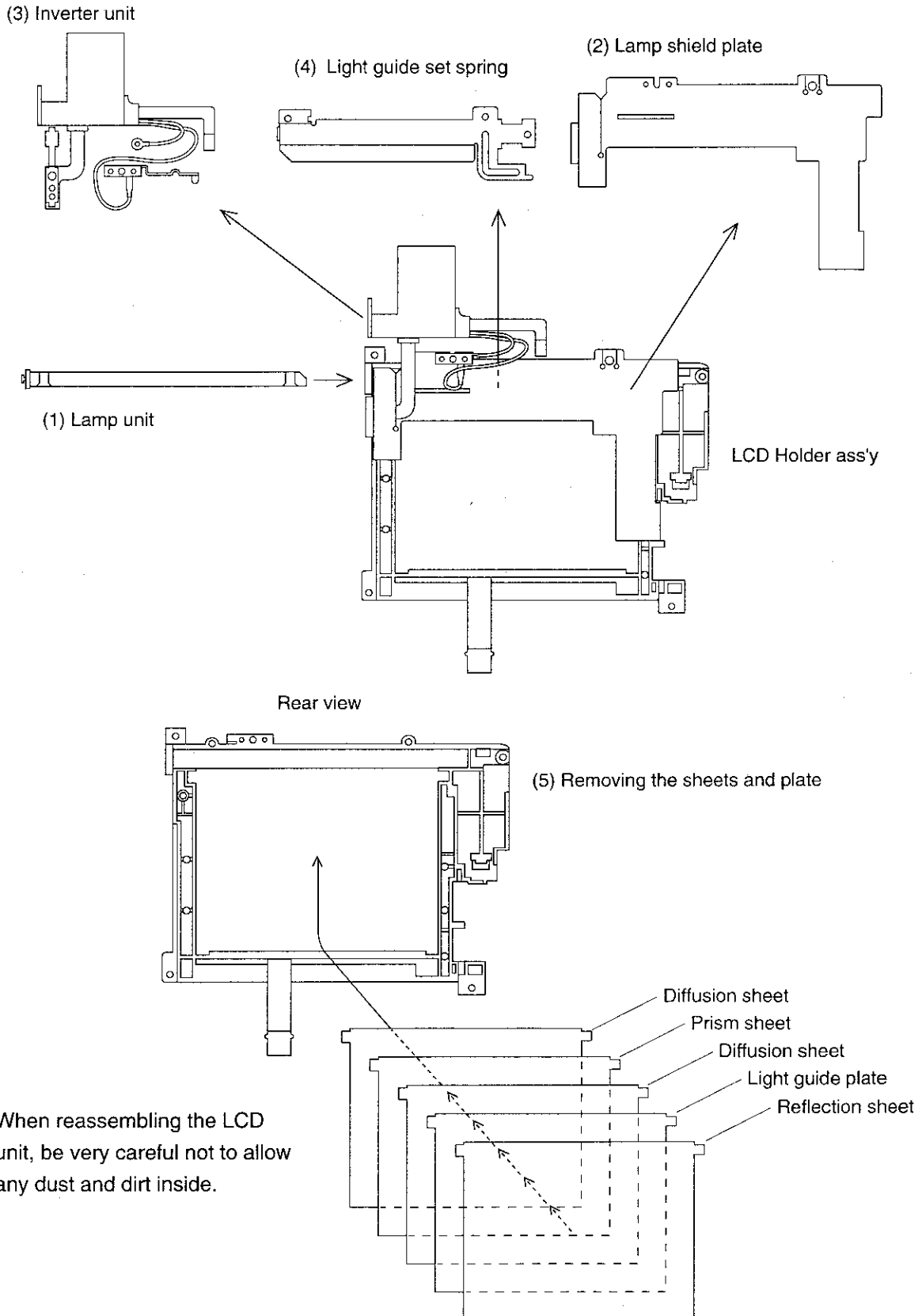

4. MECHANISM ADJUSTMENT JIGS AND PARTS

4-1. Mechanism check adjustment jigs

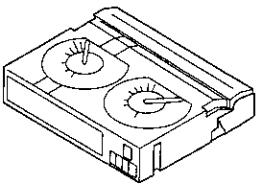
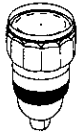
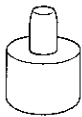
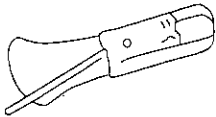
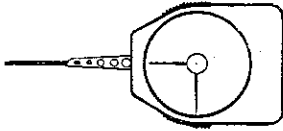
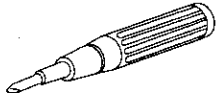
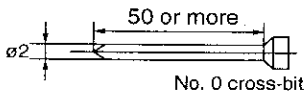
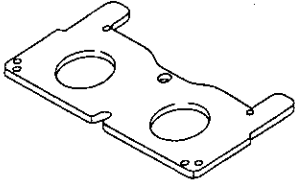
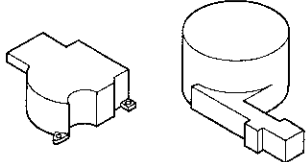
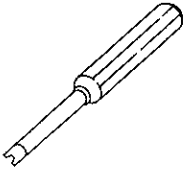
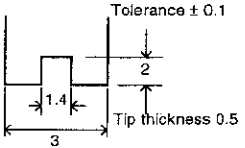
No.	Name	Part code	Shape	Model number and use
1.	PB-use cassette Torque meter	9DASD-1015		<ul style="list-style-type: none"> • SD-1015
2.	Torque gauge	JiGTG0045		<ul style="list-style-type: none"> • For use in VS-REW take up torque measurement
3.	Torque gauge head	9EQTGH-DH5000		<ul style="list-style-type: none"> • For use with the above torque gauge
4.	Tension gauge 4N (400gf)	JiGSG0400		<ul style="list-style-type: none"> • For measurement of pinch roller pressure.
5.	Dial tension gauge	9DAPTG-10-10W		<ul style="list-style-type: none"> • PTG-10
6.	Torque screwdriver 150mN•m (1.5kg•cm)	JiGTD1500RTDH		 <ul style="list-style-type: none"> • No. 0 cross-bit
7.	Master plane	9EQMP-DH5000		<ul style="list-style-type: none"> • For checking reel base height
8.	Height adjustment jig	9EQHG-DH5000		<ul style="list-style-type: none"> • For adjusting Tu guide height • For adjusting SI roller height
9.	Height adjustment screwdriver	9EQDRIVER-DH5		<ul style="list-style-type: none"> • For SI roller adjustment • For guide roller adjustment • For Tu guide adjustment • For reel base adjustment • Bit shape (see figure below) 

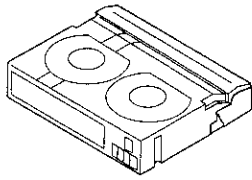
No.	Name	Part code	Shape	Model number and use
10.	Alignment tape	90ADVC-TAPEPAL		<ul style="list-style-type: none"> • For tape running adjustment (colour bar)
11.	Miscellaneous (1) Slide caliper (2) Precision screwdrivers (Phillips head and slotted) (3) Radio needle-nose pliers (4) Tweezers			

<How to make jigs for mechanism checking and adjustment>

(1) Reel hub for back tension measurement

- 1) Obtain a commercially available cassette tape reel hub. (Disassemble the cassette tape and remove the tape from the reel hub.)
- 2) Paste one end of a string (about 20cm long) to the reel hub with (for example) cellophane tape.

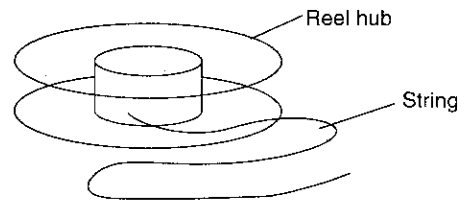

(2) String for use in pinch roller snap-fit force measurement.

- 1) Obtain an approximately 20cm length of commercially available string (diameter about 0.3mm).
- 2) Tie the 2 ends together to form a loop.

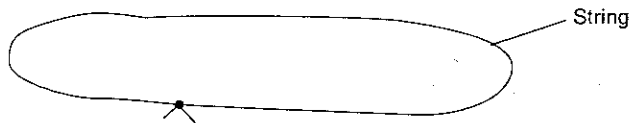

4-2. Parts for regular periodic inspection and maintenance

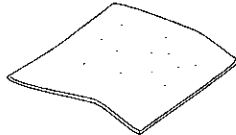
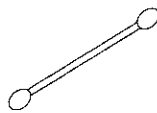
No.	Name	Part code	Shape	Model number and use
1.	Oil (1) Cosmo Hydro HV22	9EQ-OiL-HV22		* Cosmo Petroleum K.K.
2.	Cleaning paper	JIGDUSPER		<ul style="list-style-type: none"> • DUSPER (SIGMA) (ozu Co., LTD.)
3.	Extremely thin cotton swab			<ul style="list-style-type: none"> • Commercially available item
4.	Grease: Moly Coat YM-103	99FGREASE-YM103		<ul style="list-style-type: none"> • Dow Corning
5.	Screw lock (1401B)			<ul style="list-style-type: none"> • Three Bond
6.	Cleaning liquid: industrial-use ethyl alcohol			<ul style="list-style-type: none"> • Commercially available item

5. INSPECTION AND MAINTENANCE ITEMS AND INTERVALS

In order to keep the mechanical section always in good condition, perform the following inspection and maintenance at regular intervals. In addition, after repair, perform the following maintenance items regardless of how long the user has been using the unit.

5-1. List of inspection and maintenance items

	Inspection and maintenance location	Time of use (h)					Symptoms that indicate need for maintenance	Remarks
		500	1,000	1,500	2,000	3,000		
Tape running system	Tape running section (see section 7-1)	□	□	□	□	□	<ul style="list-style-type: none"> • Block-type noise • Head hole clogging • Tape damage Note: Replace the drum ass'y if the video head is cleaned but its hole is still clogged.	<Rollers> <ul style="list-style-type: none"> • Replace if there is anything abnormal in the rotation, or if there is run-out (that becomes large). <Other than the above> <ul style="list-style-type: none"> • Clean the section that contacts the tape (especially the lower drum helical section). Use the specified cleaning liquid.
	Drum section, Video head (see section 7-1)	□	□	□	□	□		
Drive system	Timing belt	—	★	—	★	★	<ul style="list-style-type: none"> • The tape fails to run. • The tape becomes slack. • Block-type noise • Abnormal noise 	<ul style="list-style-type: none"> • Replace if there is anything abnormal.
	Pinch roller	□	□	□	□○	□		
	Capstan motor	—	○	—	○	○		
	Swing arm Tu reel bases	—	★○	—	★○	★○		
	Center gear shaft PLAY gear shaft Fast gear shaft	—	△	—	△	△	<ul style="list-style-type: none"> • Abnormal noise 	<ul style="list-style-type: none"> • Lubricate with oil. [Oil] Cosmo Hydro HV22 Note: Apply oil to the shaft, then wipe lightly with a cloth.
	Tension-arm shaft	—	△	—	△	△		
	Loading motor Mode switch	—	★○	—	★○	★○	<ul style="list-style-type: none"> • Cannot eject. • Fails to enter a mode. 	<ul style="list-style-type: none"> • Replace if anything is abnormal (including the noise).
Performance checks	Abnormal noise	★	★	★	★	★	<ul style="list-style-type: none"> • The tape fails to run. • The tape becomes slack. • Tape damage • The play-back image is abnormal. 	<ul style="list-style-type: none"> • Replace any part that fails to perform within the standard.
	PB• VS/REW takeup torque	—	★	—	★	★		
	PB• VS/REW• FF• REW• loading back tension	—	★	—	★	★		
		Head cleaner	—	○	—	○	○	

[Oil] Cosmo Hydro HV22
[Grease] Moly Coat YM-103

[Screw lock] Three Bond 1401B
[Cleaning liquid] Industrial-use ethyl alcohol

○••• Replace. □••• Clean. △••• Lubricate. ★••• Check.

5-2. Precautions

- (1) When replacing any part, always replace the cut washer that was removed with a new one.
- (2) This mechanism does not have control adjustment. If the control cannot be set as required, clean and/or replace parts.
- (3) On the oil
 - a) Always use the specified oil. (Using another kind of oil can cause various kinds of trouble.)
 - b) Always use clean oil, without any mixed-in dirt, to lubricate bearings. (Using oil with dirt mixed in can cause the bearings to wear or to stick.)
 - c) One drop of oil is the amount shown in the figure below, on the point of a pin.
- (4) Perform circuit repair, tape running adjustment, etc. with the Cassette control assembly attached to the mechanism
- (5) To operate the mechanical section alone, apply voltage to the loading motor to drive it. The voltage between terminals must be DC3V or less. (Forcing the gears to turn by hand entails danger of breakage.)
- (6) To install the cassette control, push section A in the figure below. Do not push anything else.
- (7) Do not deform any of the mechanical parts.

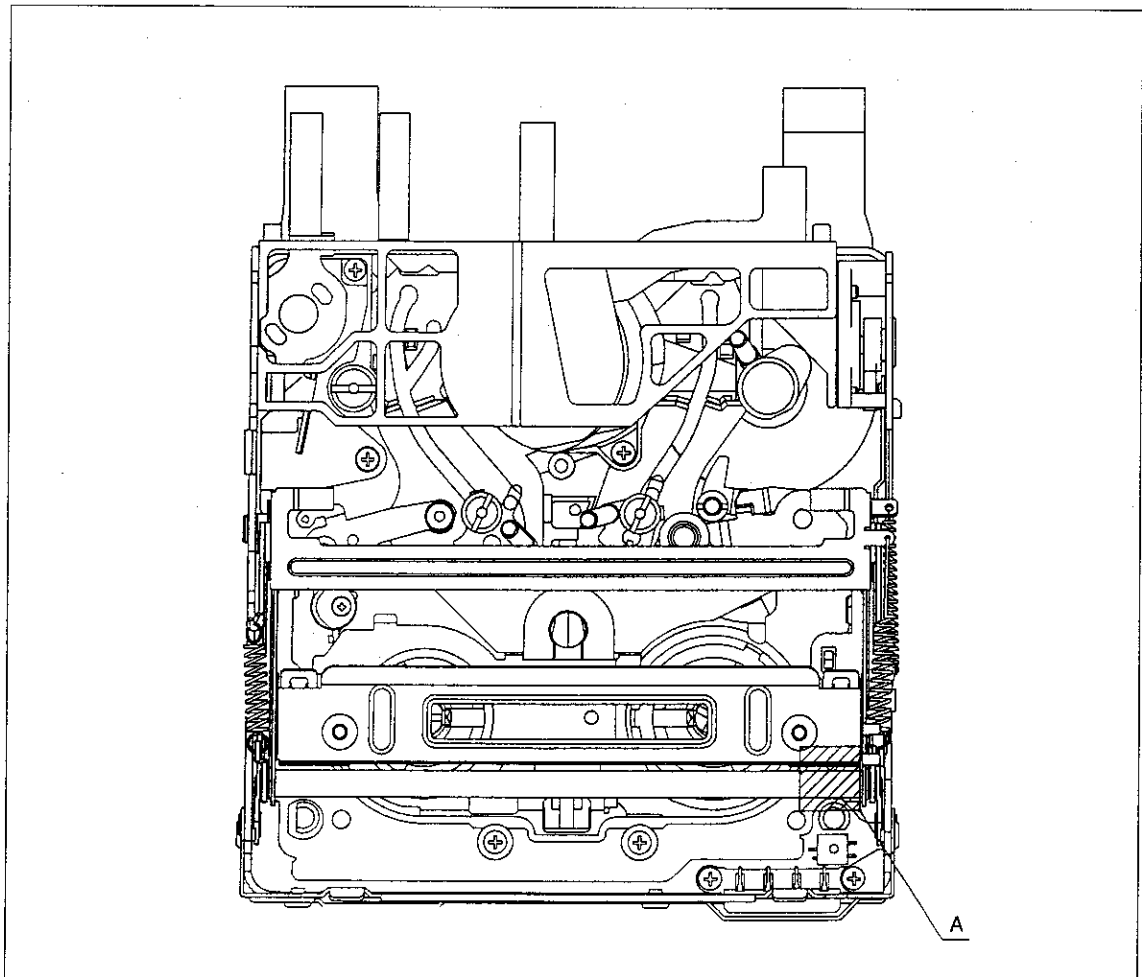
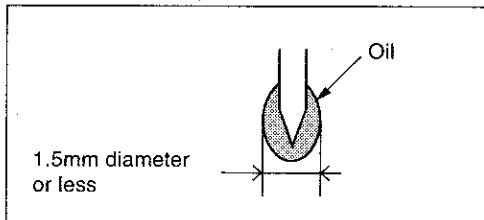

Fig. 1.

6. MECHANICAL ADJUSTMENTS AND CHECKS

The items discussed here relate to general on-site servicing (field servicing). Adjustments and replacements that require sophisticated facilities, jigs and technology are omitted.

In addition, in order to maintain the characteristics that the unit has when it is new, not only are inspection and maintenance necessary, but it is absolutely necessary that, for example, the tape not be damaged, and always use jigs for adjustments that require them.

<Precautions>

(1) Always set the power supply and state of the unit as follows for mechanism adjustments and checks.

AC adapter used, with cassette control assembly

- 6-1 Check of takeup torque during playback (recording)
- 6-2 Check and adjustment of back tension torque during playback (recording)

AC adapter used, without cassette control assembly (Independent Mechanism)

- 6-3 Check of reverse search (VS-REW) takeup torque

DC3V, without cassette control assembly (Independent Mechanism)

- 6-4 Check of reel base height
- 6-5 Check of tension post position
- 6-6 Check of FF back tension
- 6-7 Check of REW back tension
- 6-8 Check of loading back tension
- 6-9 Check of pinch snap-fit force

(2) When performing checks with a DC3V power supply and independent mechanism, disconnect the loading motor FPC from the connector.

(3) Always run the tape with the cassette control assembly attached.

6-1. Check of takeup torque during playback (recording)

(1) Set the torque cassette with the cassette control assembly attached, then, in recording mode (playback mode if a signal has already been recorded on the tape), confirm that the torque on the takeup side is within the standard.

Takeup Torque Standard During Recording (Playback)

$0.65 \pm 0.35 \text{mN}\cdot\text{m}$ ($6.5 \pm 3.5 \text{gf}\cdot\text{cm}$),
ripple $0.2 \text{mN}\cdot\text{m}$ ($2 \text{gf}\cdot\text{cm}$) or less

(If there is torque ripple, read the center value.)

6-2. Check and adjustment of back tension torque during playback (recording)

(1) Checks

With the cassette control assembly attached, set the torque cassette in place; then, in recording mode (in playback mode if a signal has already been recorded on the tape), confirm that the supply side torque is within the standard.

Torque standard $0.65 \pm 0.23 \text{mN}\cdot\text{m}$ ($6.5 \pm 2.3 \text{gf}\cdot\text{cm}$)
(If there is torque ripple, read its center value.)

(2) Adjustment

If the torque is not within the standard, adjust the position at which the tension spring is attached in Fig. 5. When the back tension torque is too high, move the spring attachment position in the A direction. When the back tension torque is too low, move the spring attachment position in the B direction.

<Caution>

After adjusting the back tension torque, always check the tension post position.

6-3. Check of reverse search (VS-REW) takeup torque

- (1) Remove the cassette control assembly; then, referring to 8-3 (3) thru (5), insert thick paper between the DOWN switch and the Tu lock release lever; then run the unit in test mode (T01) and set the system into reverse search (VS-REW) mode.
- (2) Set a torque gauge on the S reel base, then move the tension post tip in the direction of arrow A with a finger. With the tension post released, confirm that the takeup torque is within the standard. (Measure without rotating the torque gauge.)

Reverse search (VS-REW) takeup torque standard

$2.0 \pm 0.6 \text{mN}\cdot\text{m}$ ($20 \pm 6 \text{gf}\cdot\text{cm}$),
ripple $0.4 \text{mN}\cdot\text{m}$ ($4 \text{gf}\cdot\text{cm}$) or less

(If there is torque ripple, read its center value.)

- (3) After checking the takeup torque, remove the torque gauge, then remove the thick paper (refer to 8-3) that was inserted in (1). The system will automatically go into standby mode. (Absolutely do not press the EJECT lever on the VCR frame. There is danger that doing so will deform the lever and cams.)

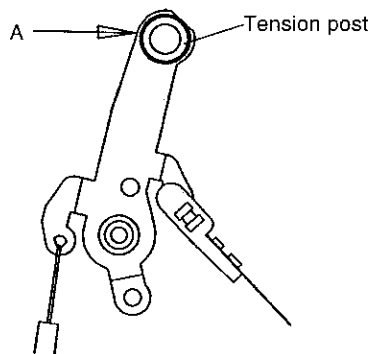

Fig. 2. How to release the tension band when measuring the reverse search (VS-REW) takeup torque.

6-4. Check of reel base height

- (1) Remove the cassette control assembly (refer to 8-2).
- (2) Referring to 8-1, apply DC3V to the loading motor and put the system into FF (REW) mode.
- (3) Taking adequate care so that the master plane does not contact drum, running parts (guide roller, etc.), or the MIC contacts. Fit the master plane holes to the 2 guides (A and B) in Fig. 3.

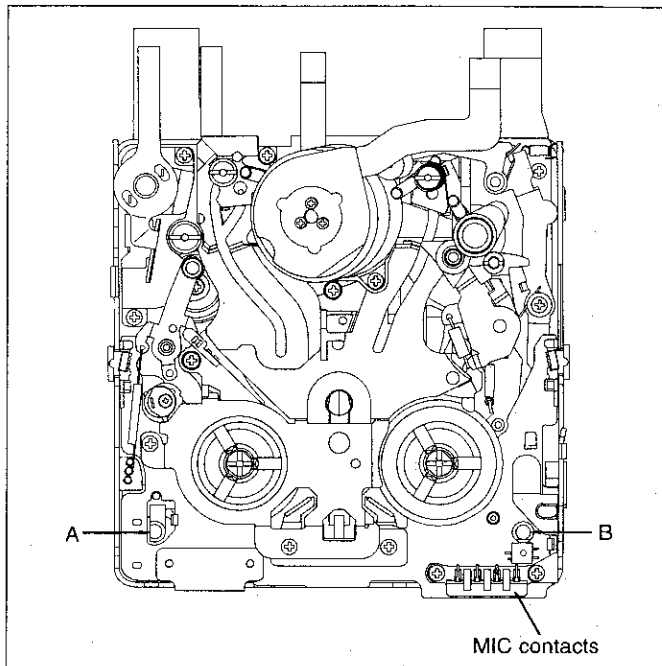

Fig. 3.

- (4) Confirm that the heights of the S reel base reel receiving surface and the Tu reel base reel receiving surface below the master plane top surface are within the set values, using, for example, a slide calliper (Fig. 4).
- (5) If these heights are not within the set values, turn the reel cap with a height adjustment screwdriver to adjust until they are within the set values.

Note: After the adjustment, make sure that the reel bases rotate smoothly. (To check the Tu reel base, release the down switch and take-up lock release-lever, referring to 8-3-(3) thru (5).)

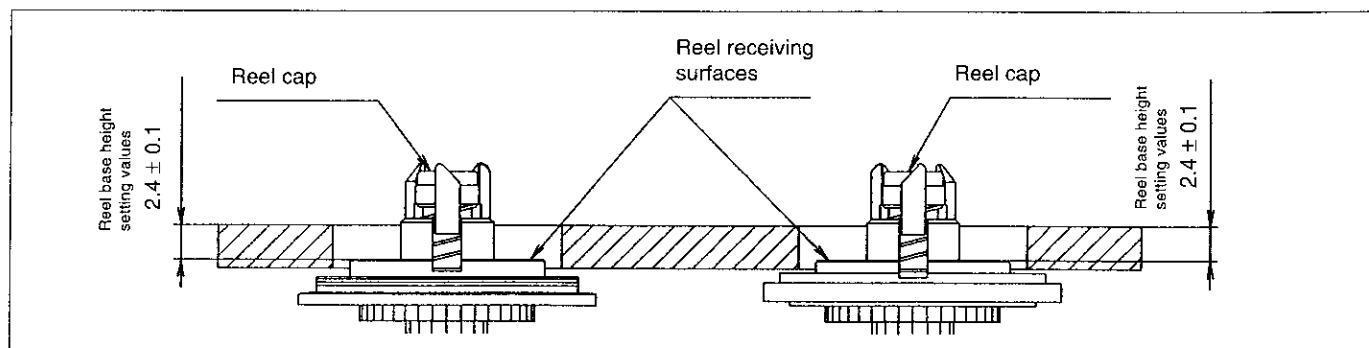

Fig. 4.

6-5. Check of tension post position

- (1) Remove the cassette control assembly, then apply DC3V to the loading motor and put the system into PB mode (without tape).
Confirm that the tension post is $8.5^{+0}_{-0.5}$ mm from the inner wall of the main chassis, as shown in Fig. 5.
- (2) If it is not at the prescribed position, adjust by turning the eccentric pin.
When the tension post is too far toward the outside, turn the eccentric pin clockwise.
When the tension post is too far toward the mechanism center, turn the eccentric pin counterclockwise.

Distance from the main chassis inner wall to the outer circumference of the tension post upper flange

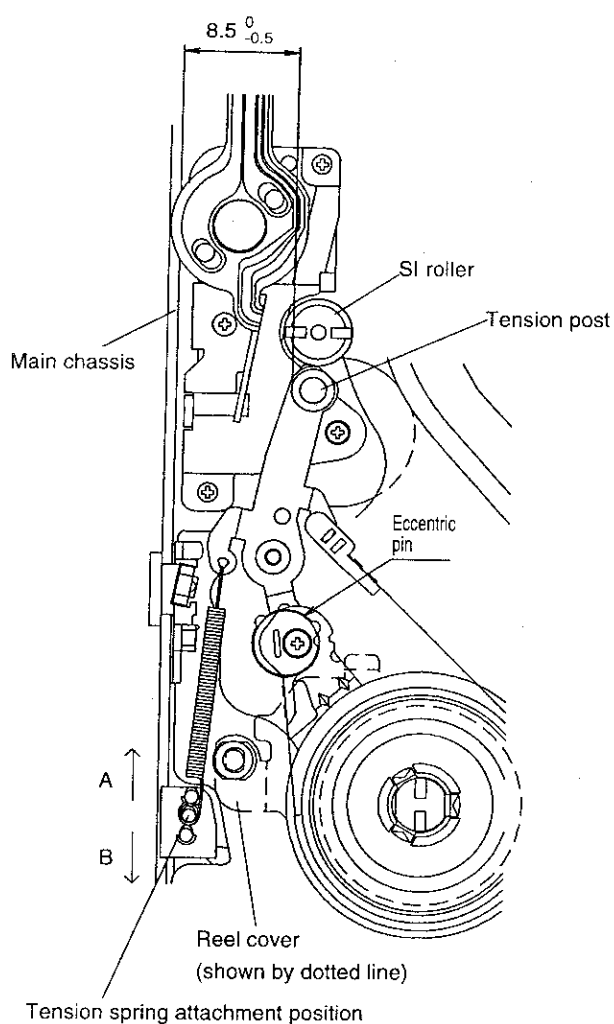

Fig. 5.

6-6. Check of FF back tension

- (1) Remove the cassette control assembly, then apply DC3V to the loading motor and put the system into FF mode (refer to 8-1).
- (2) Turn the mechanism over, then move the swing arm to the Tu reel base side, for example by using the tip of a screwdriver (refer to Fig. 7).
- (3) Set a back tension measurement reel hub on the S reel base.
- (4) Using a dial tension gauge, pull the string in the A direction, then confirm that the tension is within the standard.

FF back tension standard

$$17 \pm 12\text{mN} (1.7 \pm 1.2\text{gf})$$

(If the tension fluctuates, read its center value.)

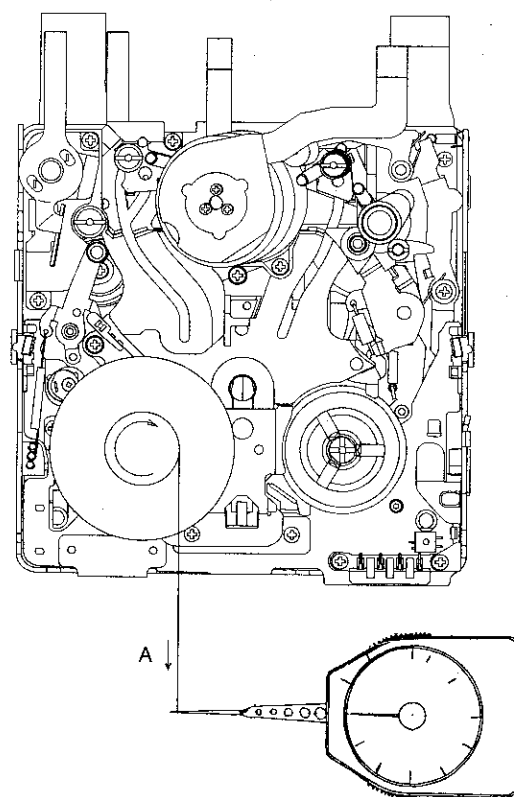

Fig. 6. How to measure the FF back tension.

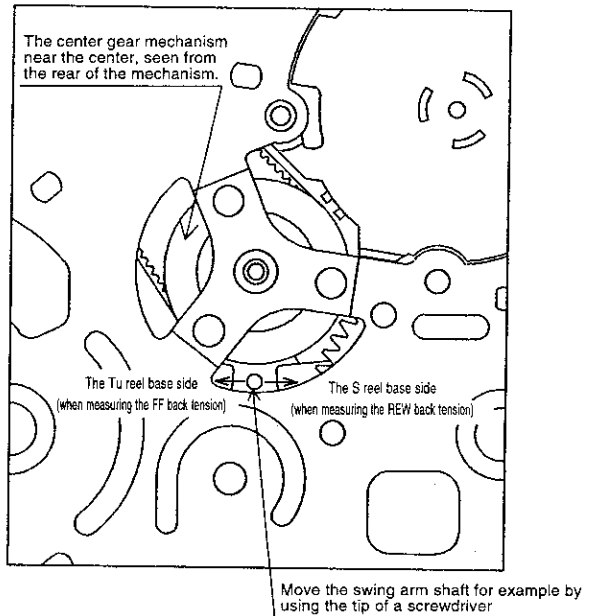

Fig. 7. The swing arm shaft position (seen from the rear of the mechanism) when measuring the FF • REW back tension.

6-7. Check of REW back tension

- (1) Remove the cassette control assembly, then apply DC3V to the loading motor and put the system into REW mode (refer to 8-1).
- (2) Referring to 8-3 (3) thru (5), insert thick paper, then release the DOWN switch and the Tu lock release lever.
- (3) Turn the mechanism over, then move the swing arm toward the S reel base side, using for example the tip of a screwdriver (see Fig. 7).
- (4) Set a back tension measurement reel hub on the Tu reel base.
- (5) Using a dial tension gauge, pull the string in the A direction, then confirm that the tension is within the standard.
- (6) Remove the paper that was inserted in (2).

REW back tension standard

$$17 \pm 12\text{mN} (1.7 \pm 1.2\text{gf})$$

(If the tension fluctuates, read its center value.)

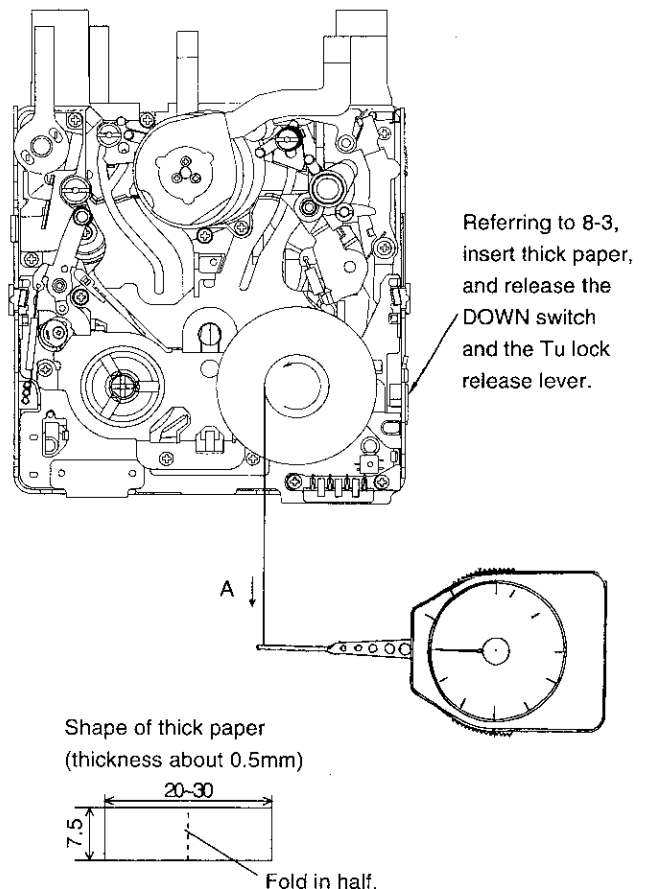

Fig. 8. How to measure the REW and loading back tension.

6-8. Check of loading back tension

- (1) Remove the cassette control assembly, then apply DC3V to the loading motor and put the system into standby mode (refer to 8-1).
- (2) Referring to 8-3 (3) thru (5), insert thick paper, and release the DOWN switch and the Tu lock release lever.
- (3) Turn the mechanism over, then move the swing arm to the S reel base side, for example with the tip of a screwdriver (see Fig. 7).
- (4) Set a back tension measurement reel hub on the Tu reel base.
- (5) With the dial tension gauge, pull the string in the A direction and confirm that the tension is within the standard. (If the tension fluctuates, read the center value.)
- (6) Remove the paper that was inserted in (2).

Loading back tension standard value
 $40 \pm 30\text{mN}$ ($4 \pm 3\text{gf}$)

6-9. Check of pinch snap fit force

- (1) Remove the cassette control Assembly.
- (2) Attach a pinch roller snap fit force measurement string to the pinch roller.
- (3) Apply DC3V to the loading motor and put the system into playback mode, then snap-fit the pinch roller onto the capstan shaft.
- (4) Hook a tension gauge onto the pinch roller snap fit force measurement string, then, as shown in Fig. 9, pull the string in the direction of the light guide to gradually remove the pinch roller from the capstan.
- (5) When the pinch roller has come off of the capstan shaft, read the tension gauge value.

<Standard>

$2.2 \pm 0.6\text{N}$ ($220 \pm 60\text{gf}$)

<Caution>

After making this measurement, quickly release the system from playback mode and remove the pinch roller from the capstan shaft. (If the pinch roller is left fitted onto the capstan shaft for a long time, the pinch roller will be deformed.)

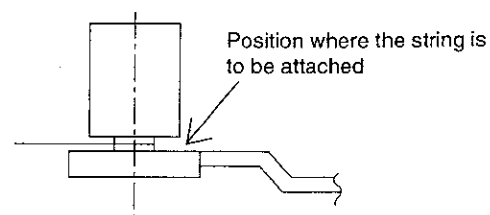
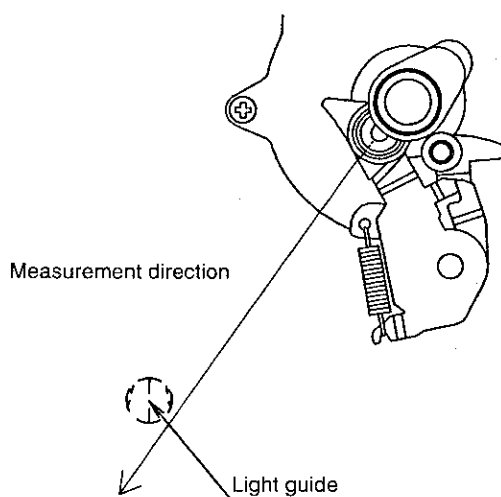

Fig. 9.

7. TAPE RUNNING ADJUSTMENT

Always make the tape running adjustment with the cassette control ass'y attached to the mechanical section.

7-1. Adjustment locations

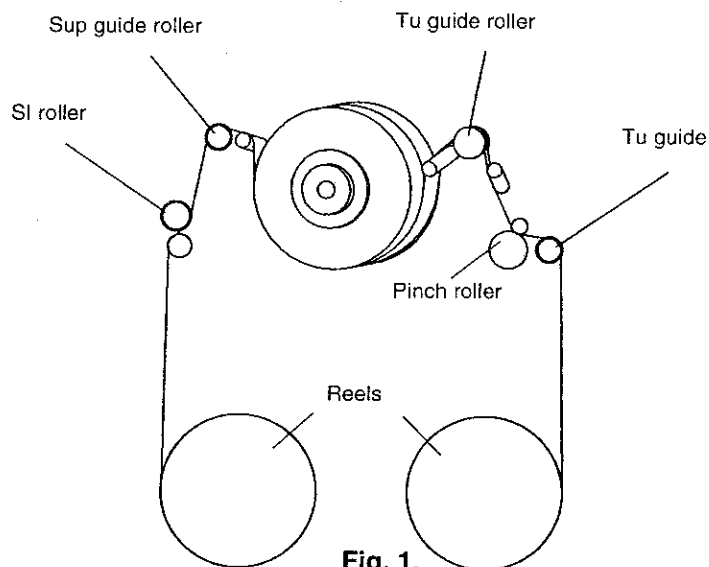
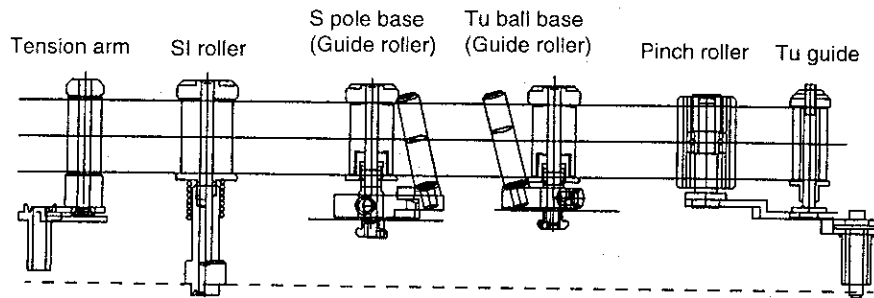
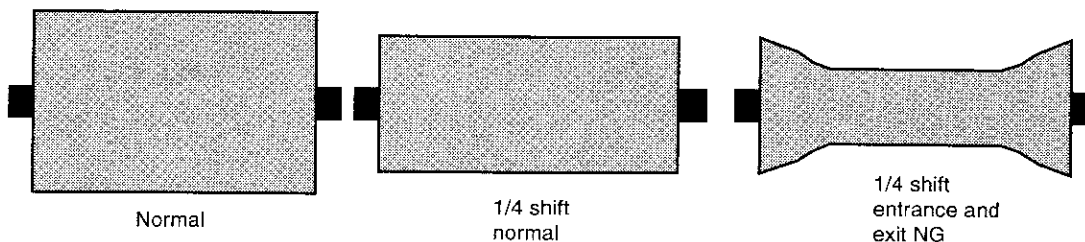

Fig. 1.

7-2. Preparation for adjustment

- (1) Clean the tape running surface (Fig. 1) (especially, adequately clean the drum surface and the lower drum helicam surface).
- (2) Connect an oscilloscope to each TP on the relay circuit board.
- (3) Turn the AC adapter power ON.
- (4) Using the adjustment remote control unit, put the system into TEST mode T05.
- (5) Replay a alignment tape for running adjustment.
- (6) Check the oscilloscope playback envelope, then, at +1/4 shift and -1/4 shift, check whether all of it is flat. If it is not, perform the following adjustment so that it becomes flat.
(Each time you push the PLAY key, the shift will change; +1/4 shift → Normal → -1/4 shift → Normal, in order.)



7-3. Steps to perform

- (1) Check and adjust the SI roller and the Tu guide height.
- (2) Adjust the Sup/Tu guide roller height.
- (3) Check the reverse search (VS-REW) envelope waveform.
- (4) Check the tape wrinkles.
- (5) Check the envelope rise.
- (6) Check the playback SWP.

<Checks and Adjustments>

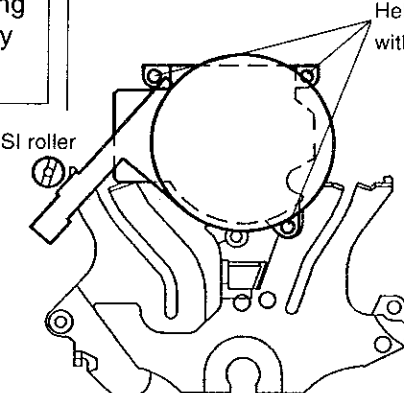
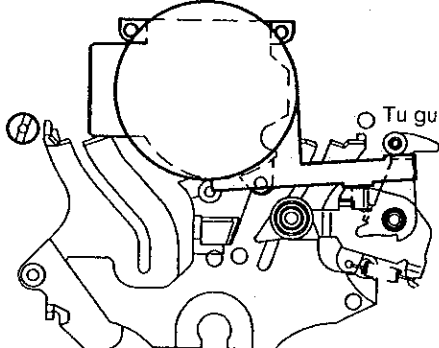
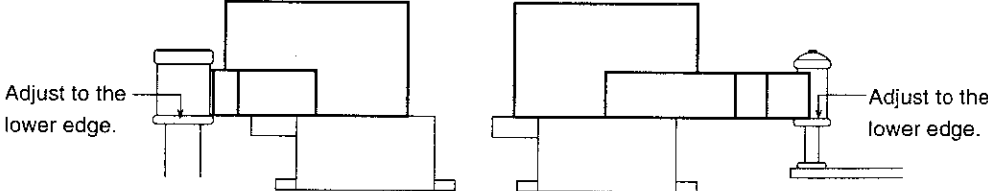
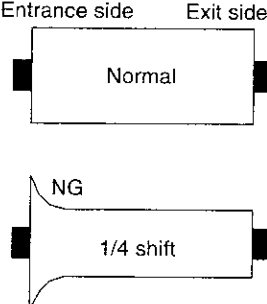
Checks and adjustments	Method	Setting values and precautions	Measuring instruments and jigs
<p>1) Si roller/Tu guide height</p> <p>Note) Perform adjustment 1) only when replacing that part itself; when replacing other parts, perform only the fine adjustment 4).</p>	<p>(1) Using a height adjustment jig, check whether the heights of each part match the preset positions. If they do not match, adjust so that they match the jig.</p>  <p style="text-align: center;">Fig. 2.</p>	<p>Setting values</p>  <p style="text-align: center;">Fig. 3.</p>	<ul style="list-style-type: none"> • Oscilloscope • Height adjustment jig • Height adjustment Screw-driver
<p>When performing the Tu guide adjustment, apply a voltage of 3V to the loading motor, then pull the Tu guide out to the position in Fig. 3.</p>			
<p>2) Sup guide roller height</p>	<ol style="list-style-type: none"> (1) Loosen the guide roller lock screw, then tighten loosely so that the roller turns easily. (2) Replay an alignment tape, and adjust the Sup guide roller so that the envelope entrance side is flat. (3) Perform a 1/4 shift, then, as in the above case, adjust until the envelope becomes flat. (4) Tighten up the Sup guide roller lock screw. 	<p>Setting values</p> <p>Entrance side Exit side</p> 	<ul style="list-style-type: none"> • Oscilloscope • Adjustment remote control • Height adjustment screw-driver • Alignment tape

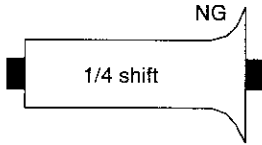
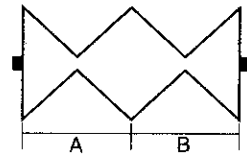
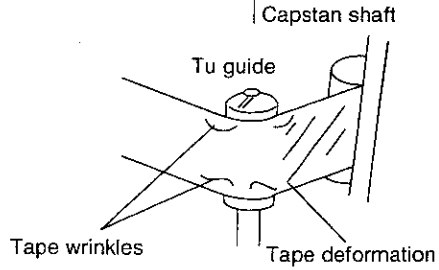
Checks and adjustments	Method	Setting values and precautions	Measuring instruments and jigs
Tu guide roller height	(1)As in the case of Sup, adjust the guide roller height so that the envelope becomes flat.	Setting values 	
3) Check of reverse search (VS-REW) envelope waveform	(1)Confirm that the envelope waveform peaks in reverse search (VS-REW) mode are uniform. (2)If they are not uniform, fine-adjust the guide roller and the Tu guide.	Setting values  Adjust so that $A \approx B$.	<ul style="list-style-type: none"> • Oscilloscope • Height adjustment screw-driver • Alignment tape
4) Check of tape wrinkles SI roller height fine adjustment	(1)In PB mode, confirm that there are no wrinkles in the SI roller tape running section. (2)If there are wrinkles, perform fine adjustment of the height. (Do not turn the SI roller over $\pm 45^\circ$.)	Setting values	<ul style="list-style-type: none"> • Height adjustment screw-driver • Alignment tape • Screw lock
Tu guide height fine adjustment	(1)In PB mode, check whether tape is being deformed between the Tu guide and the pinch roller, and whether the tape is becoming wrinkled on the upper or lower flange. (2)In reverse search (VS-REW) mode, check for deformation and wrinkles, as above. (3)If the tape is becoming wrinkled, perform fine adjustment of the Tu guide height. (4)Apply screw lock to the Tu guide upper flange.		
5) Check the rising time of the envelope.	(1)Check the rising time of the envelope when switching from reverse search (VS-REW) mode to PB mode. (2)Check the rising time of the envelope when switching from STOP mode to PB mode.	Setting value: With in 5 second.	
6) Adjustment of playback SWP	(1)Replay an alignment tape. (2)Using the adjustment remote control unit, enter SWP automatic adjustment mode.		<ul style="list-style-type: none"> • Alignment tape

8. MECHANICAL SECTION ASSEMBLY AND PARTS REPLACEMENT (DISASSEMBLY AND REASSEMBLY)

Mechanical section disassembly and reassembly are explained in this section.

For removal of the cabinet, etc., refer to **3. DISASSEMBLING THE SET.**

<Precautions>

1. Always replace cut washers that have been removed, for example in parts replacement, with new ones.
2. Turn the mechanical section over; do not place it on, for example, a desk. Deformation and scratching of mechanical parts can cause trouble.
3. When reassembling, be careful not to allow screws, washers or foreign matter to enter. They can cause mechanical misoperation.
4. Use the cleaning liquid, oil, grease and screw lock that are specified below. Use of any other kind can cause mechanical misoperation.

Oil: Cosmo Petroleum : Cosmo Hydro HV22

Grease: Dow Corning : Moly Coat YM-103

Screw lock: Three Bond :1401B

Cleaning liquid: Industrial-use ethyl alcohol

8-1. On the mechanical modes

To operate the mechanism, apply DC3V to the loading motor.

At this time, disconnect the loading motor FPC from the connector.

(1)EJECT mode

In the mechanical position in which a cassette is ejected, the EJECT lever, which is not visible through the notch window at the bottom of the chassis right side

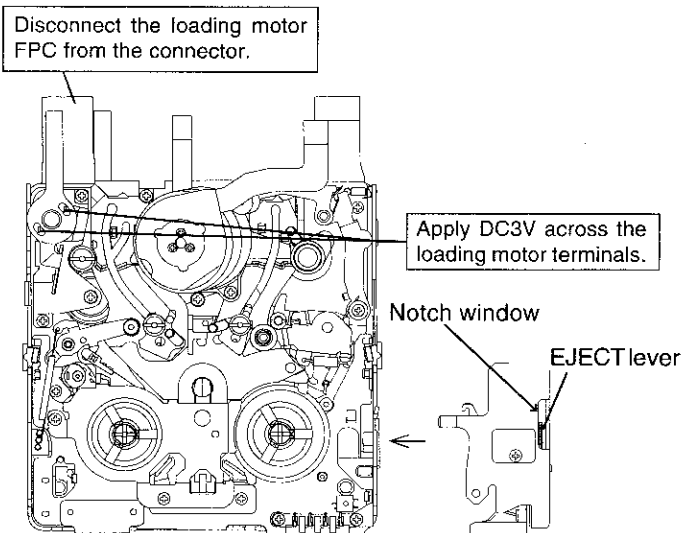

EJECT mode diagram

in standby mode, moves to a position where it is visible in this mode.

(2)STANDBY mode

In the mechanical position in which the cassette is loaded, the EJECT lever, which was in a position where it was visible through the notch window at the bottom of the chassis right side in EJECT mode, becomes invisible in this mode, so that it can be locked when the cassette control assembly is moved down.

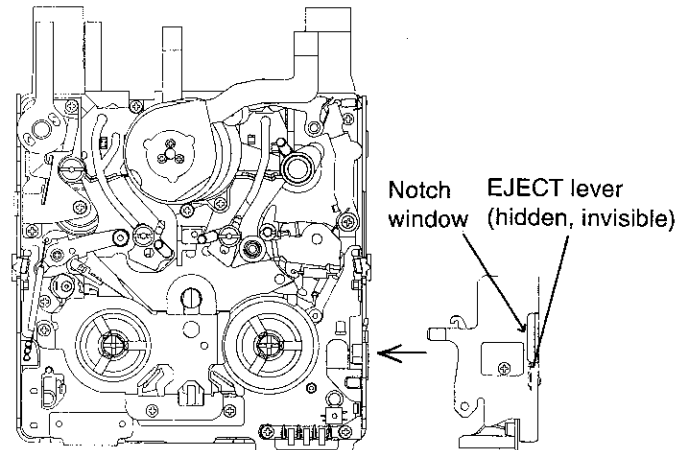

STANDBY mode diagram

(3)MIDDLE POINT mode

This is the mode where the tape is wound around the take-up reel when a cassette with visible wind start leader tape is loaded.

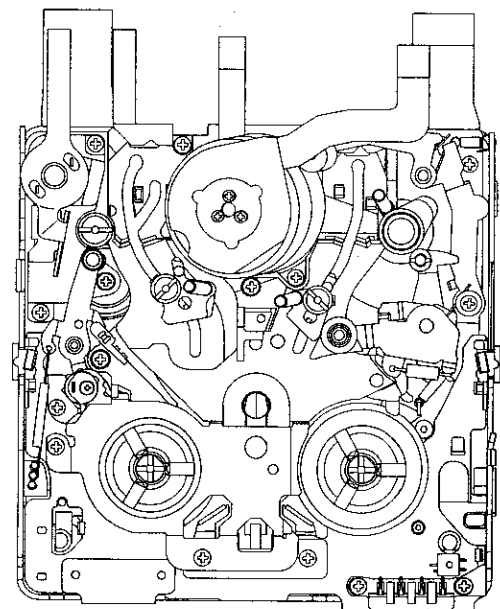

MIDDLE POINT mode diagram

(4) STOP mode

The system is in the STOP (Rec Lock in CAMERA mode) position; the S and the Tu pole bases are snap-fitted to the drum base, the S brake is in contact with the S reel base, and the Tu brake is in contact with the Tu reel base.

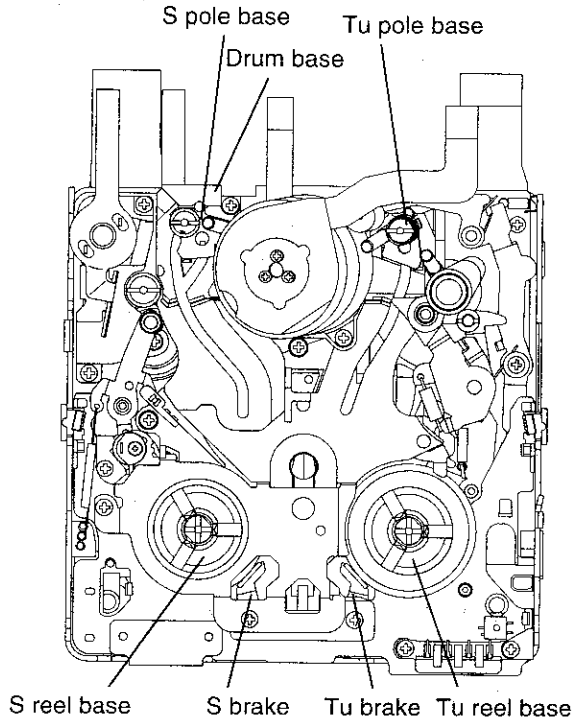

STOP mode diagram

(6) FF (REW) mode

This is the mechanical position for fast forward and rewind; compared to STOP mode, the eccentric pin rotates counterclockwise, centered on the S reel base shaft.

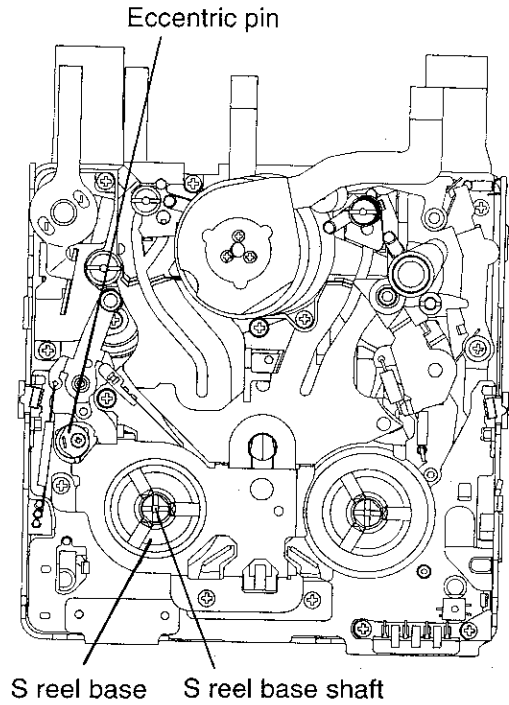

FF (REW) mode diagram

(5) PB (Rec) mode

This is the mechanical position for playback and recording; the pinch roller is snap-fitted onto the capstan shaft.

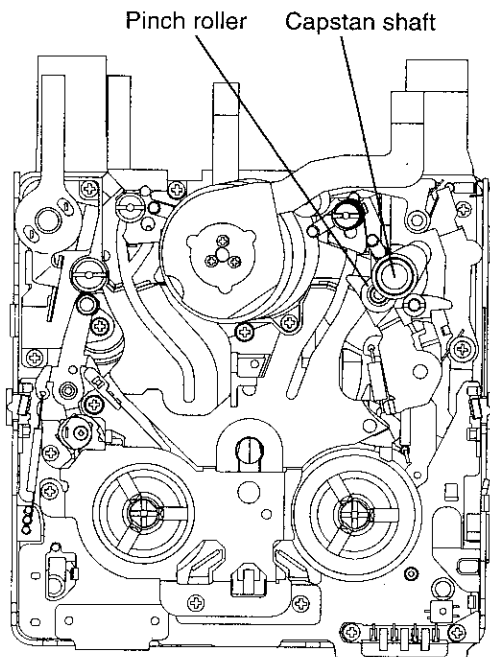

PB (REC) mode diagram

8-2. Cassette control assembly

Cassette control assembly (see Fig. 2)

<Removal>

- (1) Remove the cassette control cover.
- (2) Press the EJECT lever of the VCR frame to raise the cassette control. Or, in STANDBY mode, push the lock lever in the direction of the arrow to raise the cassette control. (See Fig. 1; direction (a) or direction (b).) (When pushing in direction (a), lift the cassette control lightly by hand to release it.)

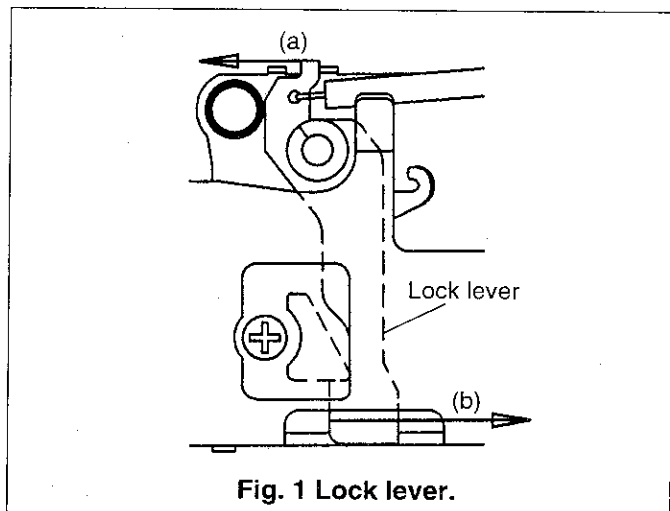

Fig. 1 Lock lever.

- (3) Remove the drum cover.
- (4) Remove the 4 screws (c), then remove the DOWN guide (d).
- (5) Remove the screw (e), then slide the damper (f) to remove it, then remove the auxiliary spring (g) from the main chassis.

- (6) Remove the cassette control outer ring shafts (2 locations (h)) from the main chassis grooves (2 locations (i)), then place them on section (j) (shown by slanting lines).
- (7) While holding the cassette control in the down position, slide the inner arm shaft (k) to the rear of the main chassis groove (round hole (l)). (At this time be careful that the damper lever (m) does not catch on the AHC release spring.)
- (8) While bending the inner arm shaft (k) slightly toward the inside, release it from the main chassis groove. (At this time be careful not to deform the inner arm.)

<How to attach>

- (1) Put the system into STANDBY mode (refer to 8-1 (2)).
- (2) Insert the inner arm shaft (k) into the main chassis groove (l) (as when it was removed, be careful not to deform the inner arm).
- (3) Place the outer link shaft (h) on section (j) of the main chassis, then, while pressing slowly on the cassette control from above, slide the shaft (h) forward and hook it on section (i) of the main chassis.
- (4) Attach the auxiliary spring (g) and the damper (f).
Tightening torque $70 \pm 7\text{mN}\cdot\text{m}$ ($0.7 \pm 0.07\text{kg}\cdot\text{cm}$)
- (5) Attach the DOWN guide. (When attaching it, press on section (n) while tightening the screw.)
Tightening torque $40 \pm 4\text{mN}\cdot\text{m}$ ($0.4 \pm 0.04\text{kg}\cdot\text{cm}$)
- (6) Attach the drum cover and the cassette control cover.

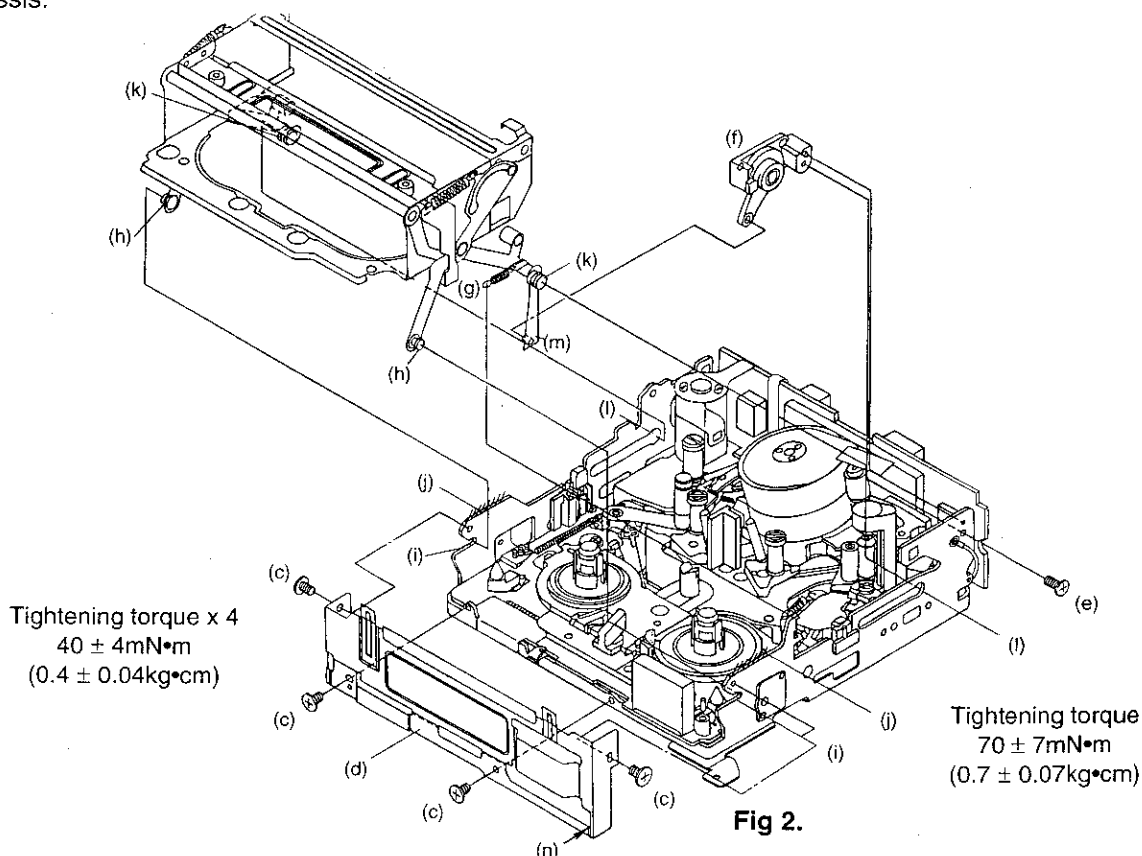

Fig. 2.

8-3. How to operate with the circuit board without the cassette control assembly.

In this method, if the procedure is followed incorrectly there is danger of damaging the mechanism and the tape, so except in special cases, such as when measuring the reverse search (VS-REW) torque, do not perform this procedure. Normally operate this unit with the cassette control assembly attached. Be sure to follow each caution mentioned.

- (1) Put the system into EJECT mode.
- (2) Connect the mechanical section to the main circuit board with the FPC jig for relay use. (Refer to 9-1.)
- (3) Remove the lock cam (1).

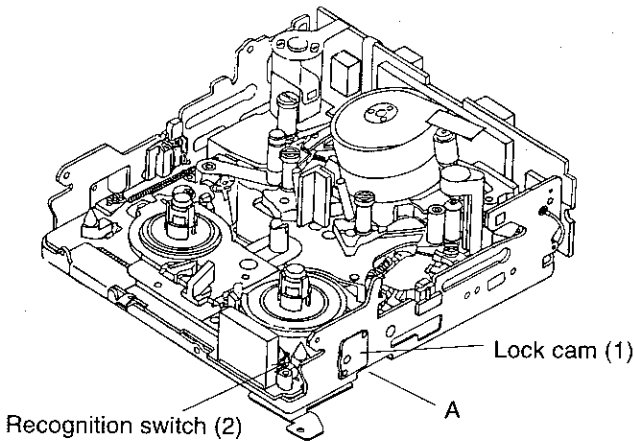
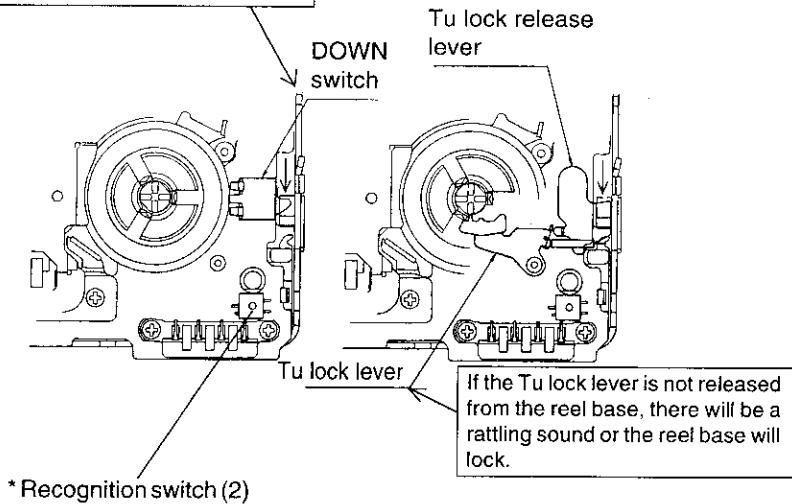

Fig. 3.

If the DOWN switch is not turned ON, a "INSERT A CASSETTE" message will appear on the liquid crystal screen and the unit will not operate.



- (4) From the front side of the mechanism, while pushing the DOWN switch and the Tu lock release lever in the direction of the arrow in Fig. 5, for example with a slotted screwdriver, insert the thick paper (about 0.5mm thick) shown in Fig. 4 from the rear side of the mechanism as shown in Fig. 5, then release the DOWN switch and the Tu lock release lever (do this in such a way that the switch will come ON). At this time, be careful not to deform the Tu lock release lever.
- (5) After releasing the Tu lock release lever, confirm that the Tu reel base rotates smoothly in both directions.

Note) If the Tu lock release lever has not been released, There will be a rattling sound; If the tape is loaded in this condition, the reel base will lock, damaging the tape and the mechanism.

Note) When putting the system into REC mode, push the pin (shown by the * mark) of the recognition switch (2) (this is not necessary in other modes).

(6) If the system is put into TEST mode (T01) with the adjustment remote control without inserting a tape, it becomes possible to operate the mechanism with the MODE key.

(7) When ejecting, remove the thick paper inserted in step (4).

Note) Absolutely do not press the EJECT lever of the VCR frame. Doing so can damage the lever and the cams.

There will be a rattling sound during the ejection, but this is not abnormal.

(Make from paper about 0.5mm thick.)

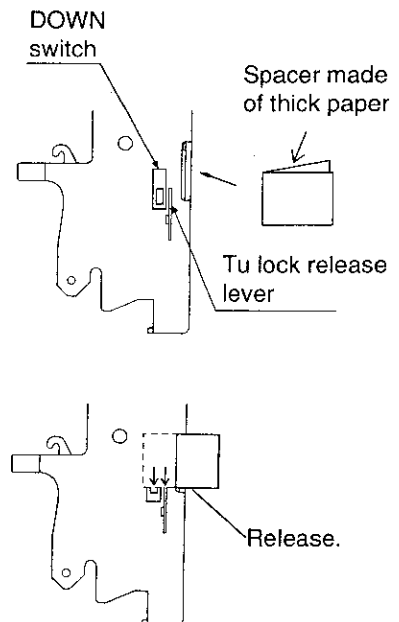
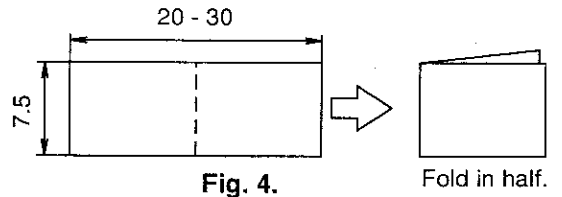

Fig. 5.

8-4. Phase matching

For the parts listed below, match the phases as shown in Fig. 6.

- (1) MODE switch
- (2) Main cam
- (3) Cam coupling gear
- (4) Pinch cam

Note) Before disassembling, check the marker positions carefully.

Note) After phase matching, turn the MODE switch by hand and confirm that it turns almost one complete turn. (After checking, return it to its original position.)

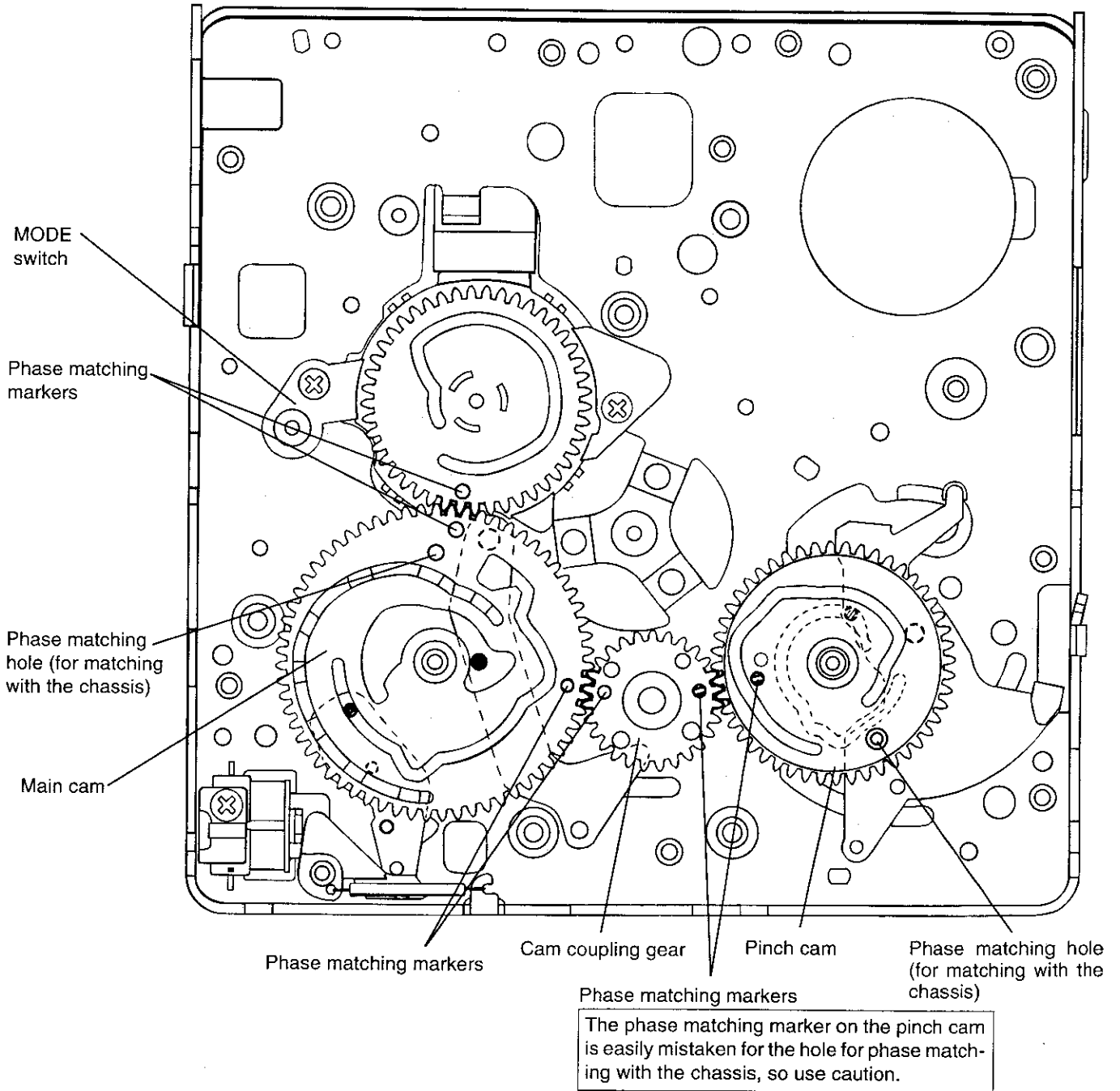
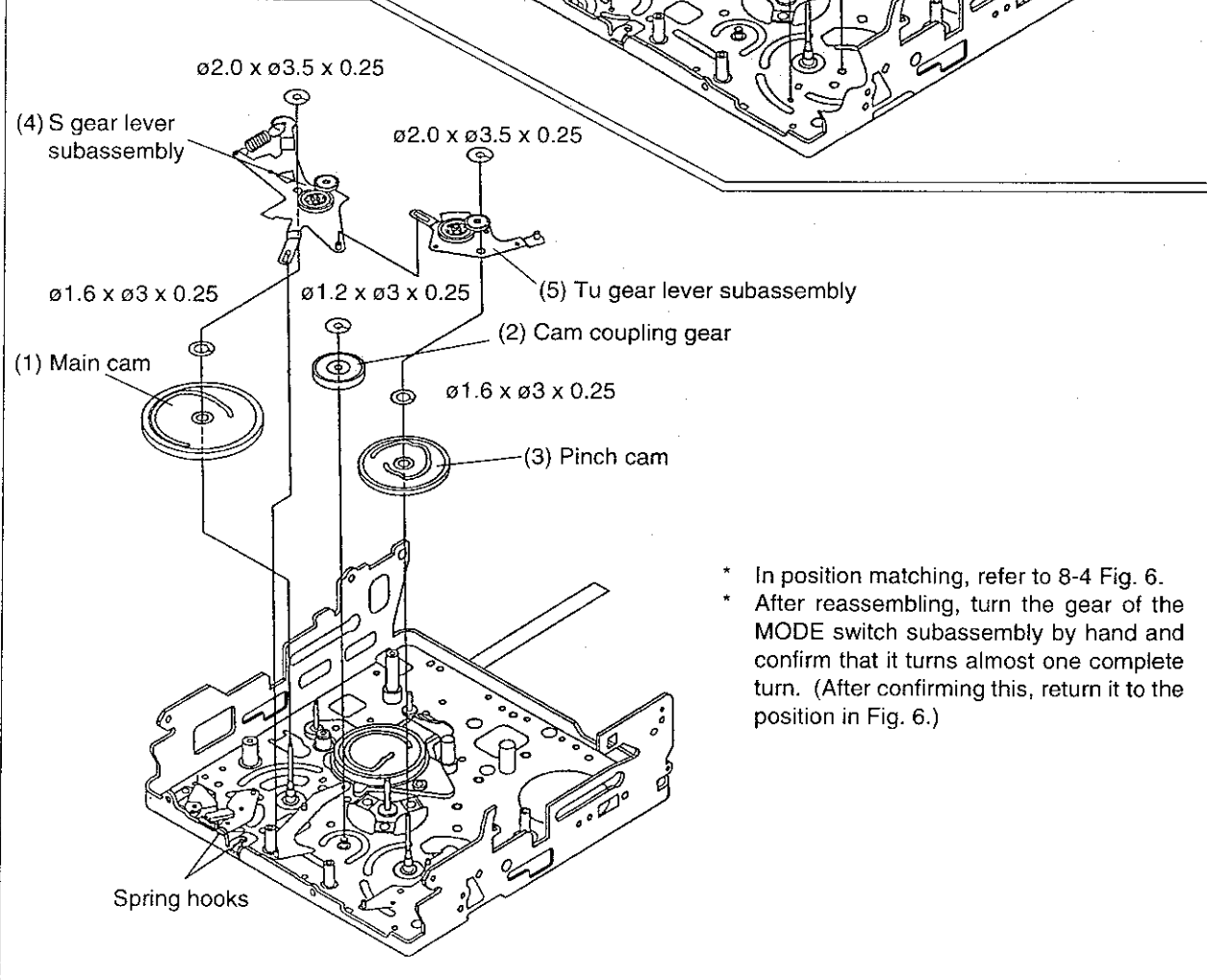
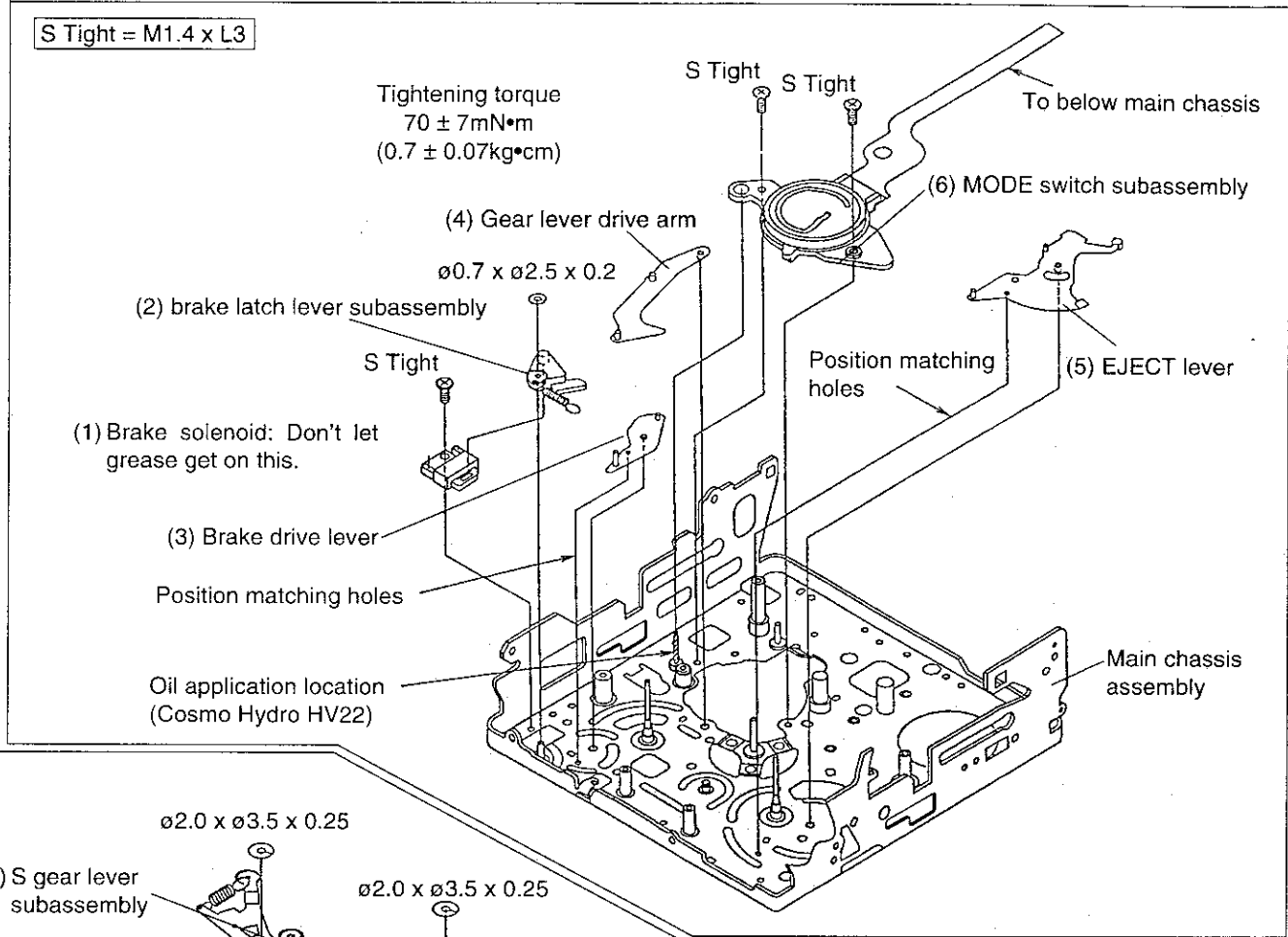

Fig. 6.

8-5. Reassembly

Note) Numbers before part names are given as a guide to the order of assembly.



- * In position matching, refer to 8-4 Fig. 6.
- * After reassembling, turn the gear of the MODE switch subassembly by hand and confirm that it turns almost one complete turn. (After confirming this, return it to the position in Fig. 6.)

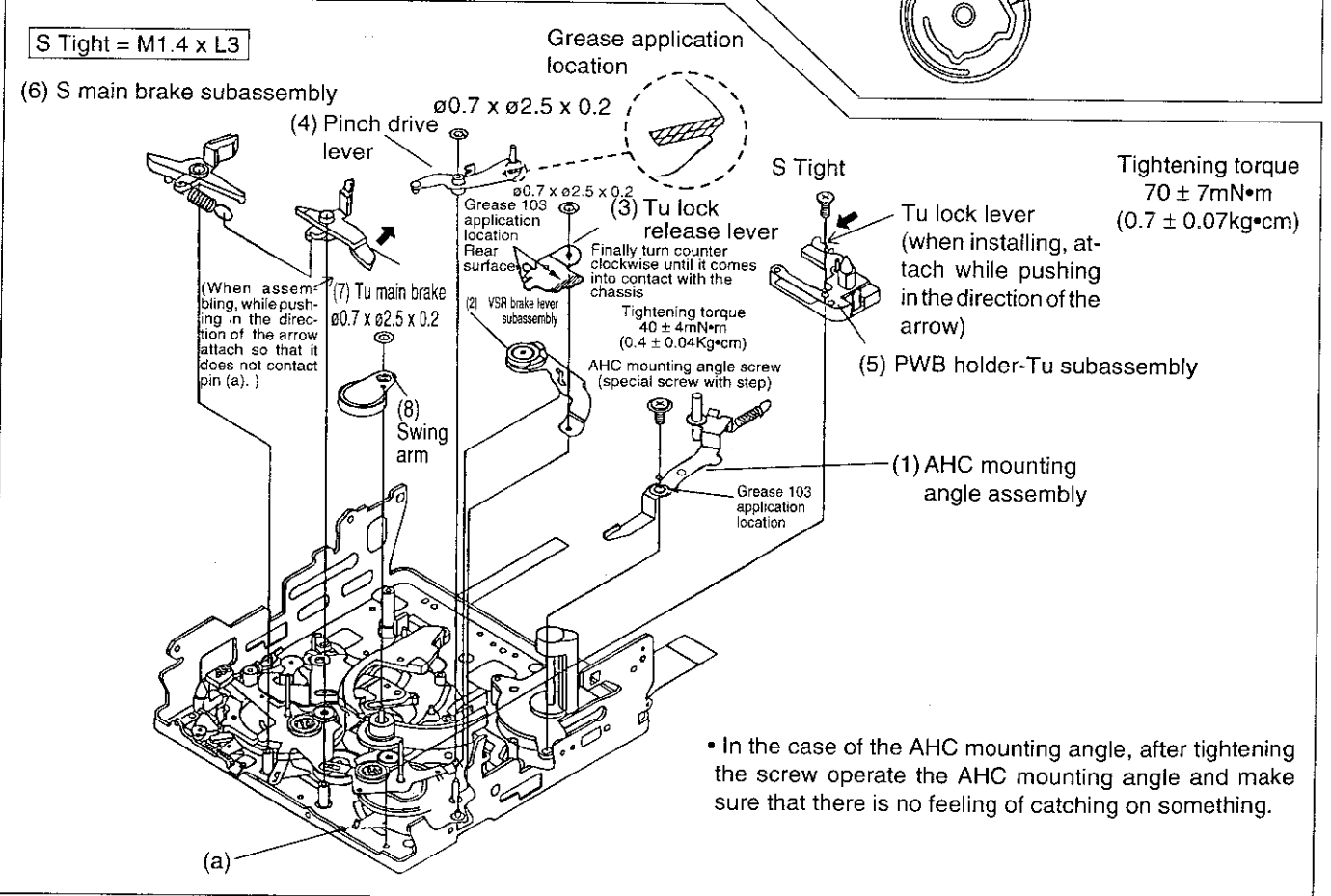
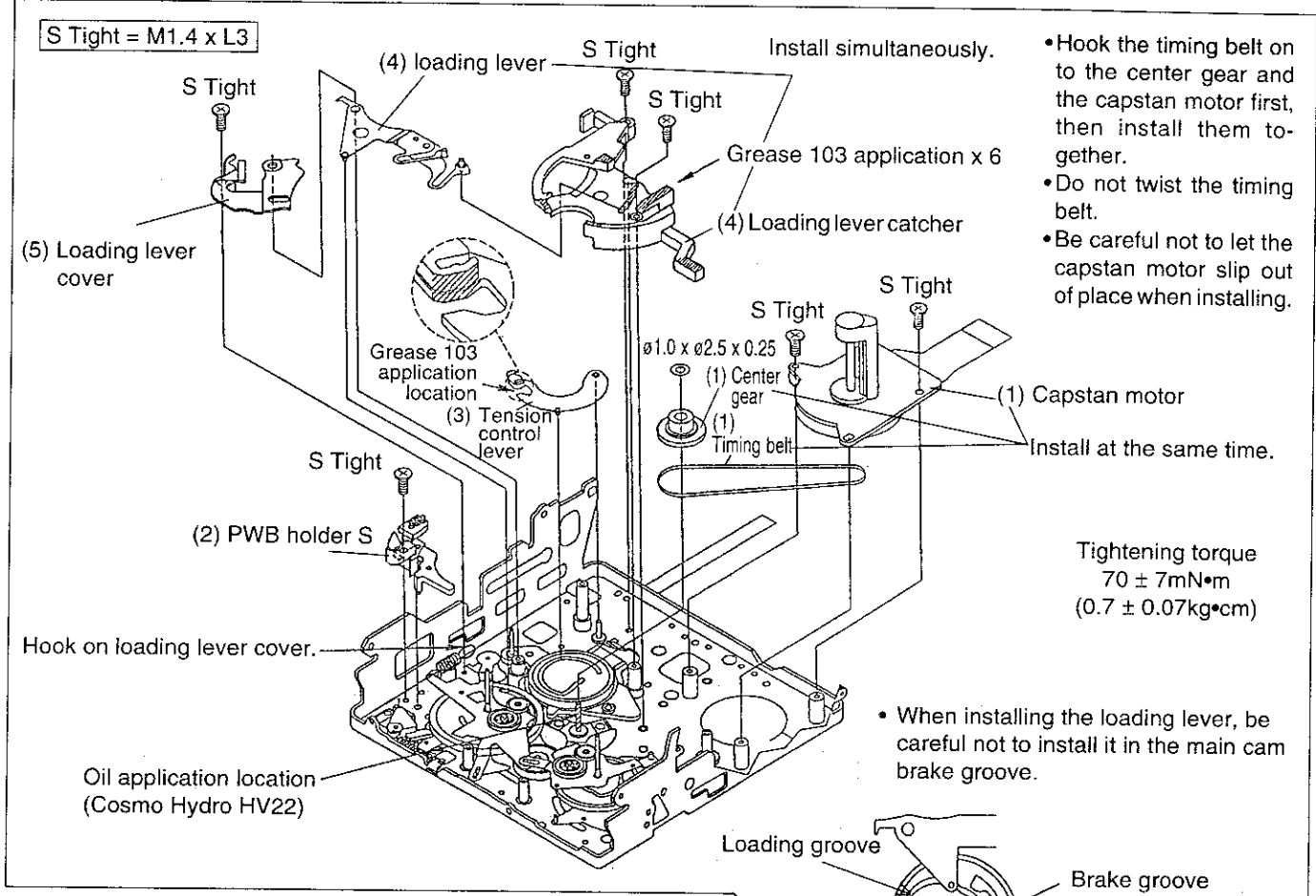

B Tight = M1.4 x L6

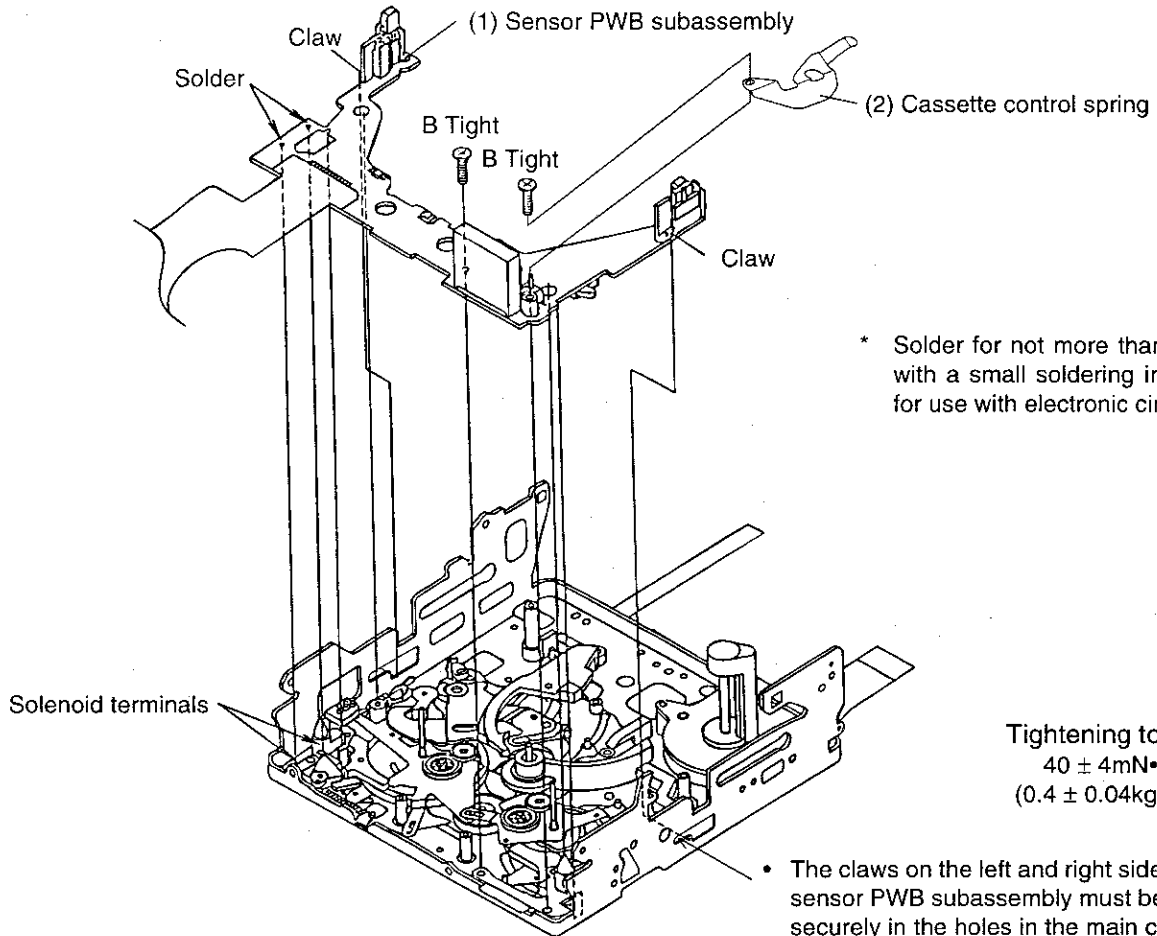

Tightening torque
 $40 \pm 4\text{mN}\cdot\text{m}$
 $(0.4 \pm 0.04\text{kg}\cdot\text{cm})$

- The claws on the left and right sides of the sensor PWB subassembly must be locked securely in the holes in the main chassis.

S Tight = M1.4 x L3

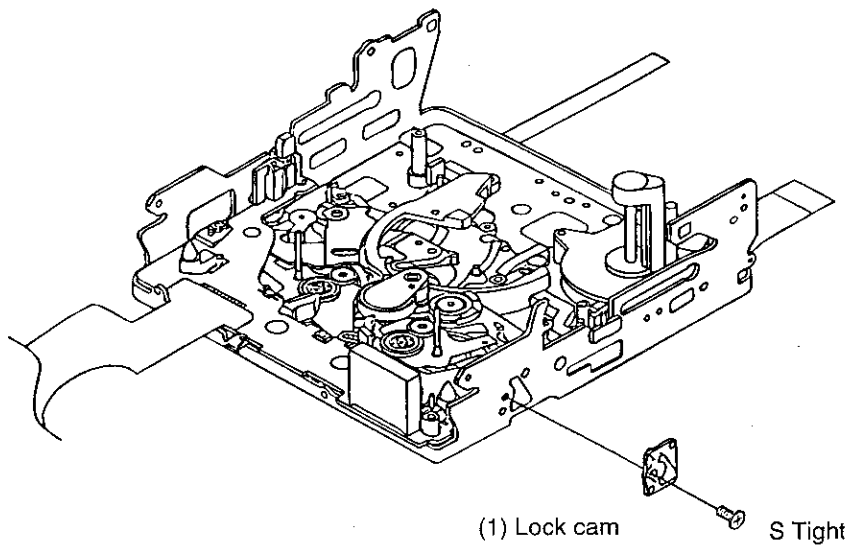

Tightening torque
 $40 \pm 4\text{mN}\cdot\text{m}$
 $(0.4 \pm 0.04\text{kg}\cdot\text{cm})$

S Tight = M1.4 x L3

Attach so that the aperture section is on the guide rail side.
 $\varnothing 0.7 - \varnothing 1.8 - t 0.2$

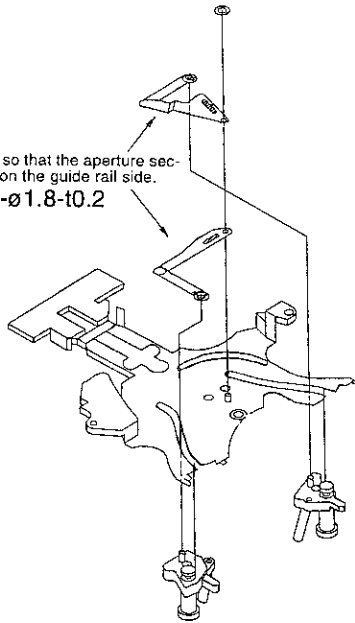

Loading motor attachment screw
 (special screw with step)

Loading motor attachment screw
 Tightening torque
 $40 \pm 4 \text{ mN}\cdot\text{m}$
 $(0.4 \pm 0.04 \text{ kg}\cdot\text{cm})$
 S Tight for loading motor use
 Tightening torque
 $70 \pm 7 \text{ mN}\cdot\text{m}$
 $(0.7 \pm 0.07 \text{ kg}\cdot\text{cm})$

(The claws are white or gray.)

(3) S reel base

(1) Loading motor subassembly

S Tight

S Tight

(4) Tu reel base

(The claws are black.)

A ~ D: S Tight

(2) Tu reel stopper

(2) Guide rail assembly

Tightening torque
 $40 \pm 4 \text{ mN}\cdot\text{m}$
 $(0.4 \pm 0.04 \text{ kg}\cdot\text{cm})$

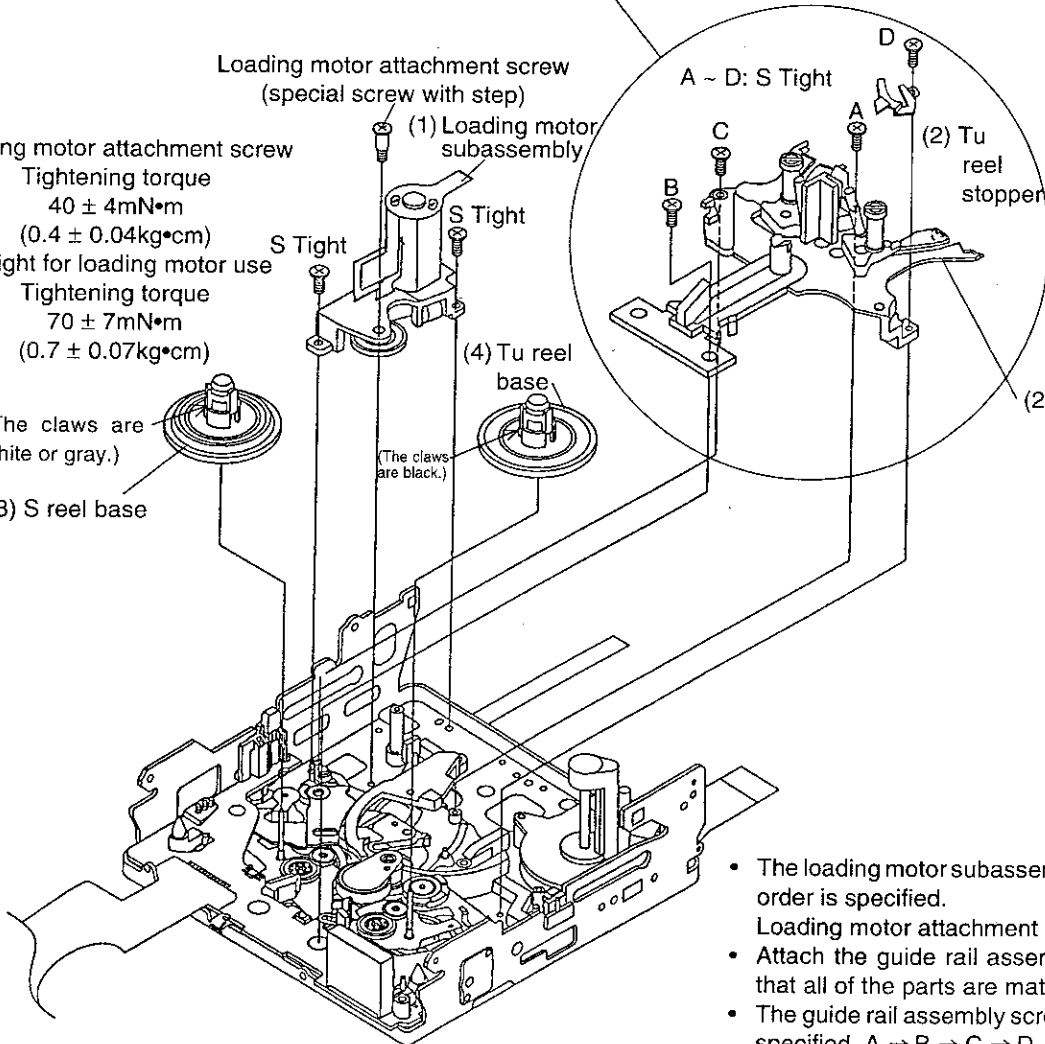

- The loading motor subassembly screw tightening order is specified.
 Loading motor attachment screw → S Tight x 2
- Attach the guide rail assembly after confirming that all of the parts are mated.
- The guide rail assembly screw tightening order is specified. A → B → C → D

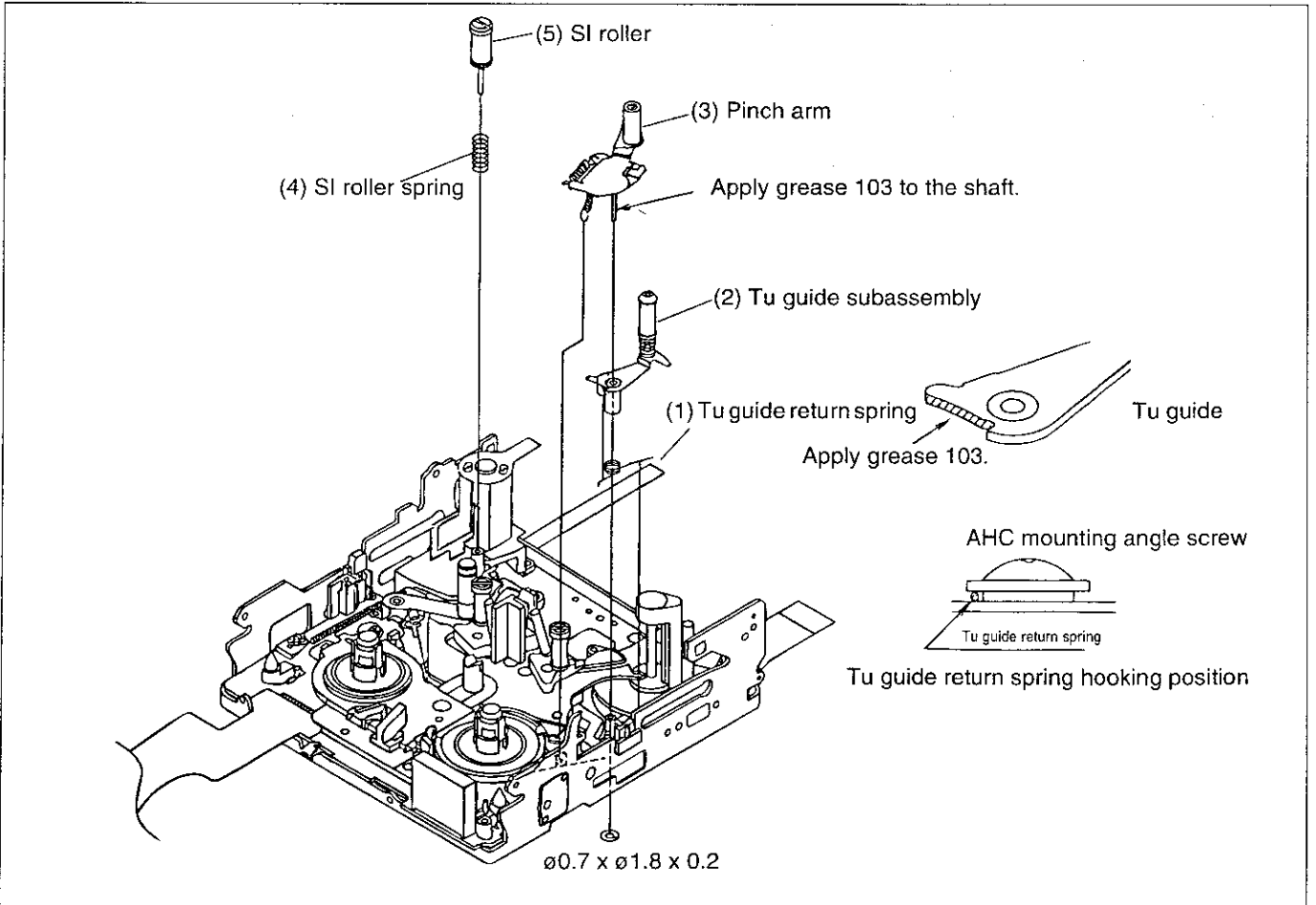
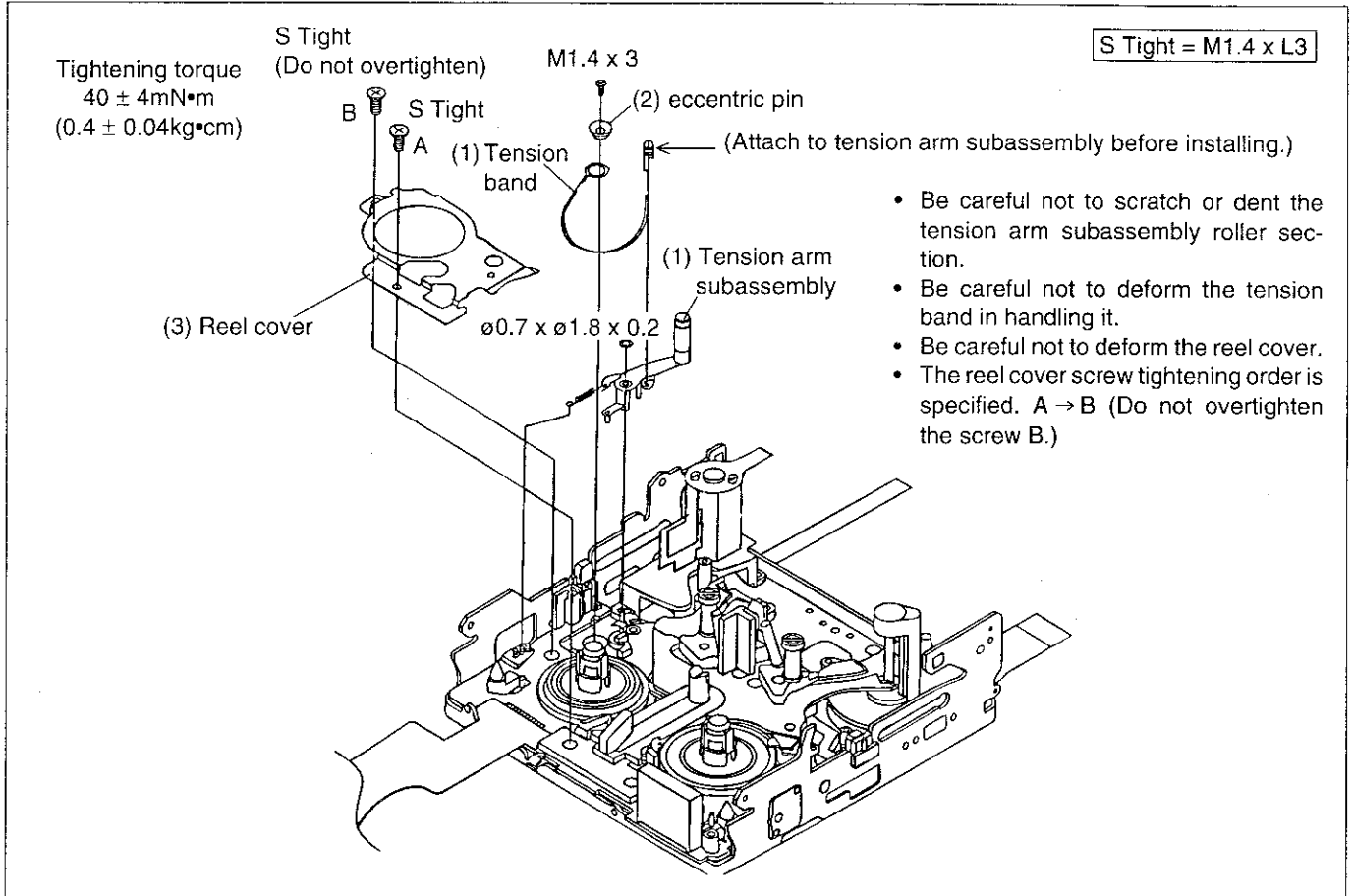

Tightening torque
 $70 \pm 7\text{mN}\cdot\text{m}$
 $(0.7 \pm 0.07\text{kg}\cdot\text{cm})$

S Tight = M1.4 x L3

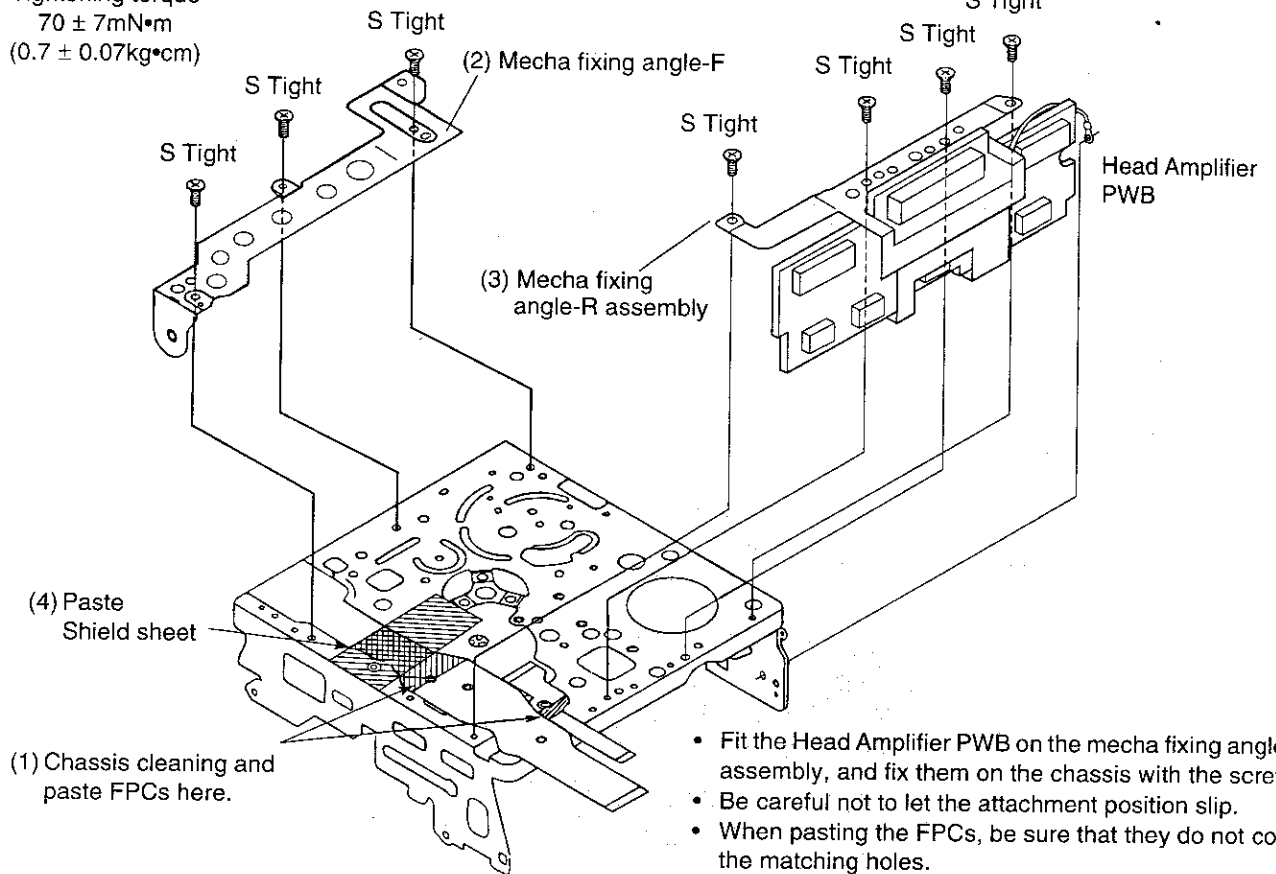

(1) Chassis cleaning and paste FPCs here.

- Fit the Head Amplifier PWB on the mecha fixing angle-R assembly, and fix them on the chassis with the screws.
- Be careful not to let the attachment position slip.
- When pasting the FPCs, be sure that they do not cover the matching holes.
- Paste the shield sheet along the mecha fixing angle-F. (Do not touch the pawl of the mode switch rotating part.)

- (1) Insert the FPC into the connector.
- (2) Lay the ground lead as shown below.

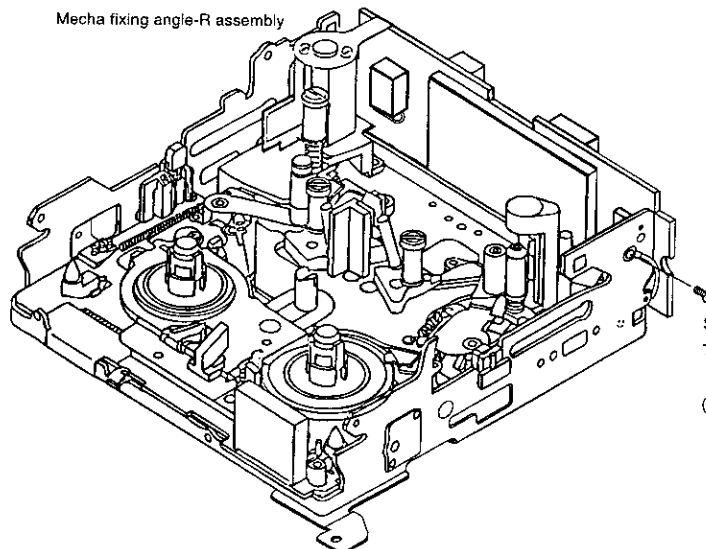
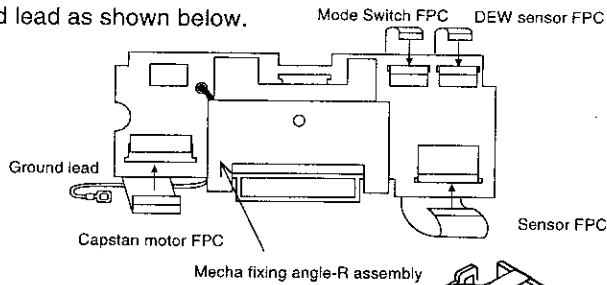

Screw M1.4 x 1.6
 Tightening torque
 $70 \pm 7\text{mN}\cdot\text{m}$
 $(0.7 \pm 0.07\text{kg}\cdot\text{cm})$

S Tight = M1.4 x L3

Tightening torque
 $70 \pm 7\text{mN}\cdot\text{m}$
 $(0.7 \pm 0.07\text{kg}\cdot\text{cm})$

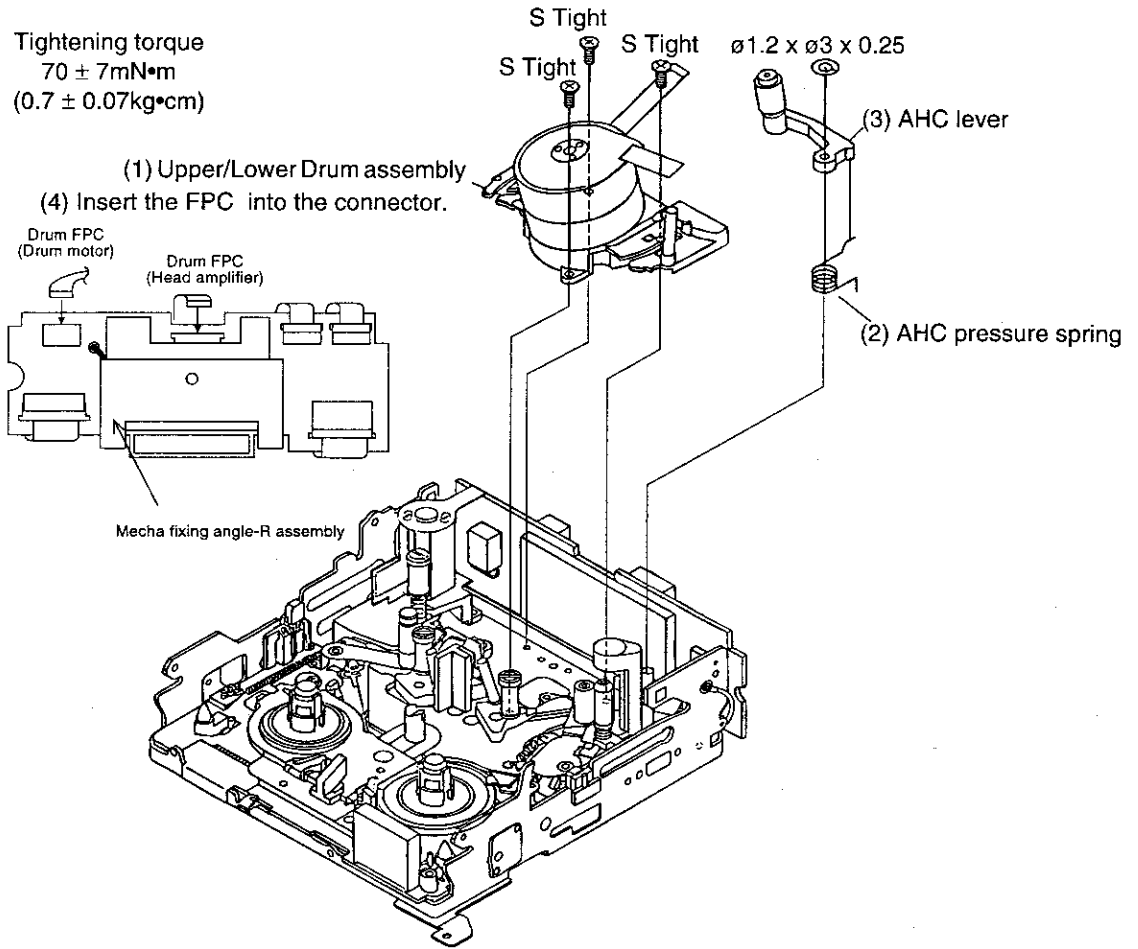

9. ADJUSTING THE ELECTRICAL CIRCUITS

— Precautions for making adjustments —

- The adjustment methods described herein are used, in most cases, when the expendable mechanical parts, including the video head, have been replaced, at which time the electrical circuits need to be readjusted. Before adjusting the electrical circuits, make sure that the mechanism works properly (i.e., the mechanism is properly adjusted). In case of the occurrence of any problem to the electrical circuits, be sure to use the specified measuring instruments to locate the area to which the problem is occurring, and then take the necessary action, including repair, replacement or adjustment, exactly as instructed in the electrical adjustment methods that will follow.
Do not attempt to make adjustments without using the proper measuring instruments.
- This machine is configured so that the electrical circuits inside its PWB unit are composed, for the most part, of high-density, small surface-mounted component parts for downsized machine body.
To perform repair service or parts replacement, do so using a soldering iron, but in as short a time as possible; this is because surface-mounted component parts are generally so small in size and susceptible to heat, as compared with the large discrete parts used in TV sets, desk-top video decks, etc., that attempting to heat their electrodes for a longer time than is necessary with a soldering iron may result in their becoming defective.
This applies particularly when replacing the laminated chip capacitors.
For this purpose, ceramic soldering irons with a temperature regulator are recommended (iron tip temperature 250°C and soldering time 5 seconds or shorter).

9-1. Adjusting the LCD video screen

- | | | |
|---|---------------------------------------|---|
| • Measuring jigs | • Oscilloscope | • Vector scope |
| • Colour monitor screen | • Frequency counter | • DC power supply |
| • Digital voltmeter | • Blank video cassette | • Alignment tape 90ADVC-TAPEPAL (colour bars) |
| • Signal generator (NTSC pattern generator LCG-401/401YC, made by Leader) | • DC cable (supplied with AC adaptor) | |
| • Audio signal generator (CR generator) | • Extension cable for video section | • Adjustment remote control |
| • AC adaptor | | |
| • Stereo AV output cable (supplied) | | |

Specifications of service jigs

NO.	Connected to or between:	Connector REF. NO.	No. of pins	Pitch	Cable length	Part code
1)	H/A ↔ VCR	P306 ↔ SC3401	80B-B	0.5		QCNW-1398TAZZ
(1)	H/A	P306	↓	↓		QPWBN2582TAZZ
(2)	VCR	SC3401	↓	↓		QPWBN2583TAZZ
(3)	FFC		20	↓	200	QCNW-1370TAZZ
2)	Battery terminal	P2702 ←	14			QTANZ0108TAZZ Used with product units
3)	Power switch	SC5 ↔ power switch unit	8	0.8		QCNW-1429TAZZ
4)	GUI OPE.	SC705 ↔ UNIT	8	↓		QCNW-1429TAZZ
5)	VCR ↔ LCD panel	SC805 ↔ LCD	24	0.5		QCNW-1382TAZZ
6)	VCR ↔ INV	SC8901 ↔ INV	7	↓		QCNW-1265TAZZ
7)	VCR ↔ system terminal	P2401 ↔ system terminal	60B-B	↓		QTANZ0109TAZZ Used with product units
8)	CAM1 FFC	SC902 ↔ SC3	20	↓		QCNW-1370TAZZ
9)	CAM2 FFC	SC903 ↔ SC4	19	↓		QCNW-1381TAZZ
10-1)	CAM ADJ	P6 ←				QCNW-1220TAZZ
-2)			26	0.8		QCNW-1368TAZZ
11)	EJECT SW	P703 ←	3			QSW-Z0224TAZZ Used with product units
12-1)	Power switch (when operating VCR conversion)	SC903 ↔ No.-of-pins conversion	19	0.5		QCNW-1381TAZZ
-2)	PWB independently)	Conversion from 18 to 19 pins				QPWBF2612TAZZ
-3)		No.-of-pins conversion	18	0.5		QCNW-1356TAZZ
-4)		↔ power switch jig				QPWBF2550TAZZ
13)	CAM ↔ VCR	P201 ↔ P1401	4	1.25		QCNW-1420TAZZ
14)	Adjustment remote control					RRMCG0033TASA

* Jig No. 12 is used only in the case where the VCR PWB is operated independently for reasons such as because there is no camera or because no camera is required.

[CIRCUIT BOARD DIAGRAM CONFIGURATION]

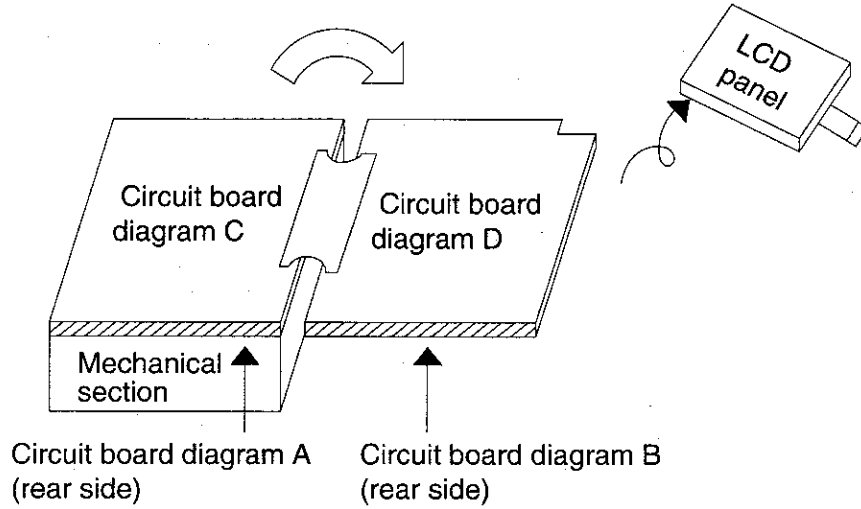

(CIRCUIT BOARD DIAGRAM C)

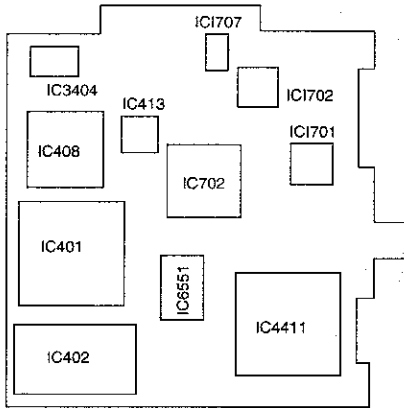

(CIRCUIT BOARD DIAGRAM D)

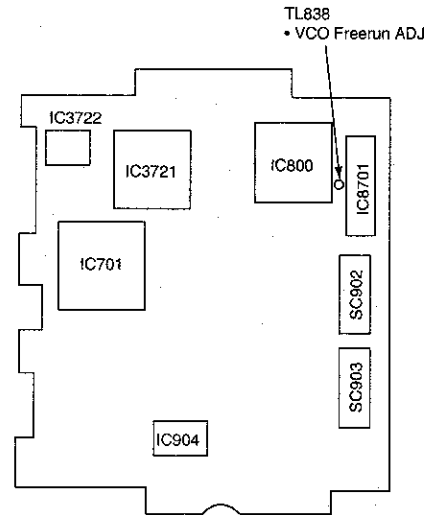

(CIRCUIT BOARD DIAGRAM A)

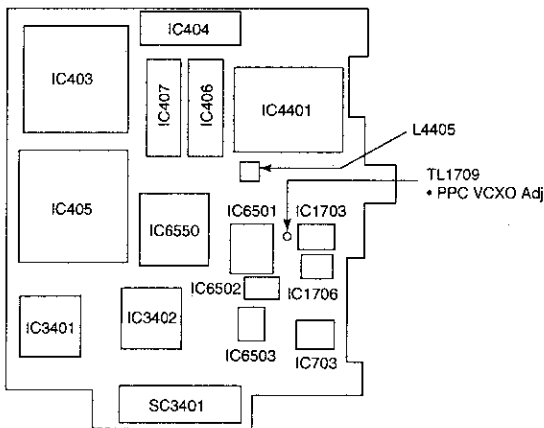

(CIRCUIT BOARD DIAGRAM B)

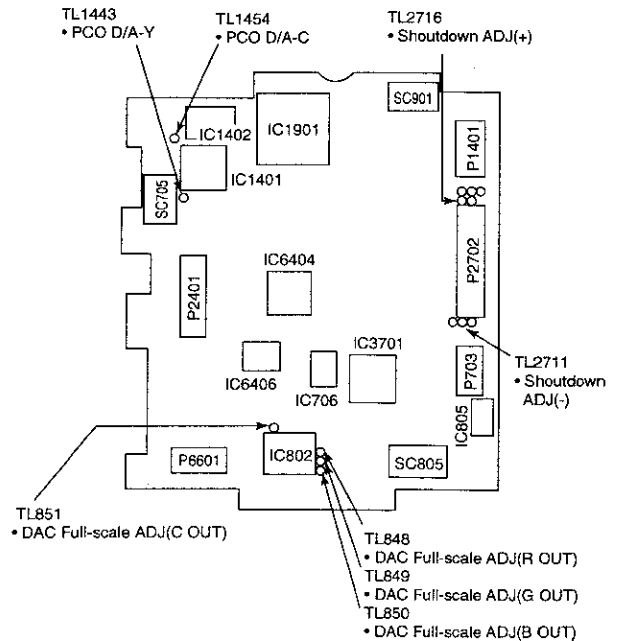

[Making adjustments]**Adjusting the servo system controller and related parts****1. Setting the system codes**

Replacement of IC706E²PROM requires the following data to be set in this order.

[Procedure]

Set the unit to the VCR mode and set the data for each address.

	Address	Data
1) Model code	01	01
	09	FE
2) Destination code	02	0B (VL-DC1E), 0A (VI-DC1H/S)
	0A	F4 (VL-DC1E), F5 (VL-DC1H/S)
3) Specifications code	03	08
	0B	F7
4) Menu selection code	04	00
	0C	FF
5) Software switching code	05	00
	0D	FF
6) Calendar switching code	07	96
	0F	69
7) 1/4 track	1F	FF

When replacing the E²PROM, first make the followig settings and then start the adjustments.

Backlight

Address	Data
10	F8
11	CC
12	89
13	44
14	BC
16	48
17	66
18	87
1B	01
1C	00

Power

Address	Data
3B	82
3C	80

LCD

Address	Data
43	2C
4B	E2
4C	E7
4D	F6
4E	99
4F	2A
51	C6
52	2C
53	AC
54	CE
55	CE
56	F2
58	5C
59	11
5A	11
5B	F9
5C	01
5D	40
5E	08
64	62
69	40
6A	40
6B	40
6C	40

Electromagnetic conversion

Address	Data
25	80
26	80
27	48
28	80
2B	DA

* Some adjustment step numbers are followed by when to perform the adjustment.

Examples

- 1) During E²PROM replacement
- 2) During circuit board (Main) replacement
- 3) During LCD replacement
- 4) During mechanism replacement

2. Shutdown voltage adjustment

(CIRCUIT BOARD DIAGRAM B)

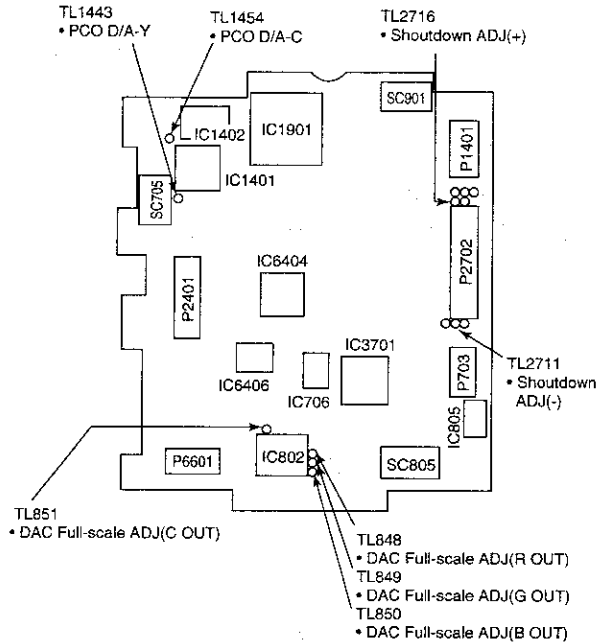

1) During E²PROM replacement

[Procedure]

- 1) Load the blank cassette into the deck.
- 2) Set the unit to the camera mode, and start recording.
- 3) Press the "CONTINUE" and "TEST SEL" keys on the adjustment remote control in this order.
- 4) Select T03 with the "REW" and "FF" keys and press the "PLAY" key.
→ This shifts the operation mode to the shutdown voltage adjustment mode.
At this time, the display in which T03 is flashing changes to the normal REC screen.
- 5) Measure the voltage between TL2716 (+) and TL2711 (-) using the digital multi-meter, and supply external power until the power voltage is adjusted to +2.80 VAC.
- 6) Press the "backlight compensation (▶/◀)" key. (The backlight compensation indicator changes from blue to yellow.)
→ This executes automatic adjustment.
At this time, with the "BATTERY" indication appearing only for an instant, the adjustment is complete.
- 7) Press the "CONTINUE" key on the adjustment remote control.

3. HSWP adjustment

[Procedure]

- 1) Play back the alignment tape in the video mode.
- 2) Press the "CONTINUE" and "HSWP ADJ" keys on the adjustment remote control in this order.
→ This executes the HSWP adjustment.
When the adjustment is successful, the blue LCD lights up and the cassette is automatically ejected. If not properly adjusted, the red LCD lights up and the tape stops automatically.

- 1) During mechanism replacement
- 2) During E²PROM replacement (IC303 inside the head amplifier circuit board)

Adjusting The PPC Circuit

1. PPC VCXO adjustment

(CIRCUIT BOARD DIAGRAM A)

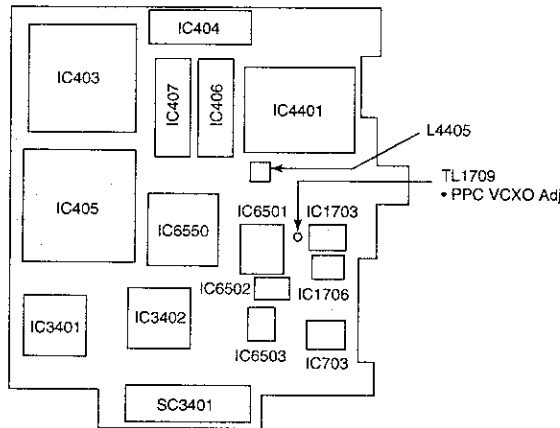

[Procedure]

- 1) Connect the camera and VCR sections so that the camera's video signal can be fed.
- 2) Set the power switch to the camera mode.
- 3) Adjust L4405 so that the DC voltage at TL1709 be $3.2 \pm 0.1V$.

ADJUSTING THE ELECTROMAGNETIC CONVERSION CIRCUIT SYSTEM

Note: During the adjustment of the electromagnetic conversion circuit system, keep R3602 out of operation.

1. PLL VCO adjustment

[Procedure]

- 1) Play back the alignment tape (or a self-recorded tape).
- 2) Call the adjustment mode (V-ADJ).
- 3) Set the address to "2C," and call the data.
- 4) Using the FF key, vary the data that has been called until the playback image screen changes to the blue back screen. Then use the REW key to vary the data backward until the data point is found where the screen starts to switch from the blue back to the playback image. At this time, take note of the data obtained at this point.
- 5) As in the above step (4), vary the data that has been called - this time using the REW key - until the playback image screen changes to the blue back screen. Then use the FF key to vary the data backward until the data point is found where the screen starts to switch from the blue back to the playback image. At this time, take note of the data obtained at the point.

- 1) During Circuit board (Main) replacement
- 2) During IC4401 or L4405 replacement

- 1) During Circuit board (Main) replacement
- 2) During E²PROM replacement

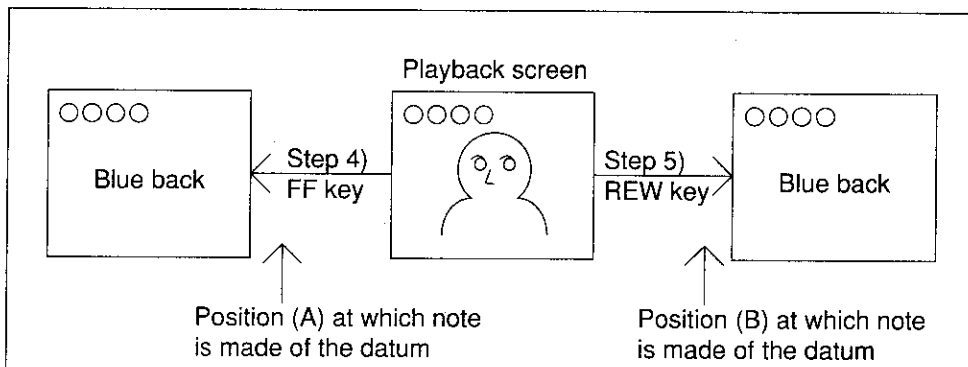

- 6) Calculate the data taken note of at the points (A) and (B) to find the center of these data, and shift to and determine the central data by using the FF or REW key.

Example:

If the data taken note of at the points (A) and (B) are 5A and 65, respectively:

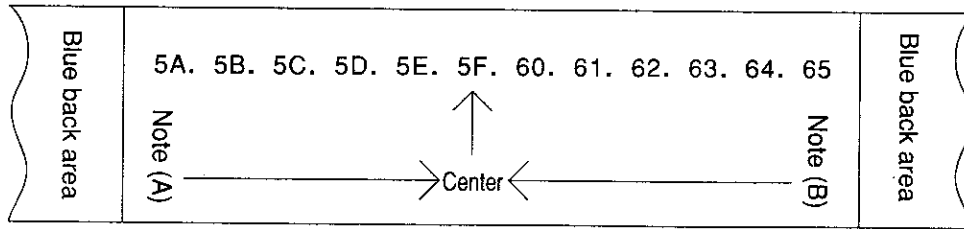

The central data is set to "5F."

Phase and equalizer adjustment → (Performed in the VCR mode)

- 1) Load a self-recorded tape into the deck.
- 2) Select and fix the TEST MODE 0F on the adjustment remote control, and the automatic adjustment will start (i.e., the following sequence is executed automatically).

- 1) During mechanism replacement
- 2) During circuit board (Main) replacement
- 3) During E²PROM replacement

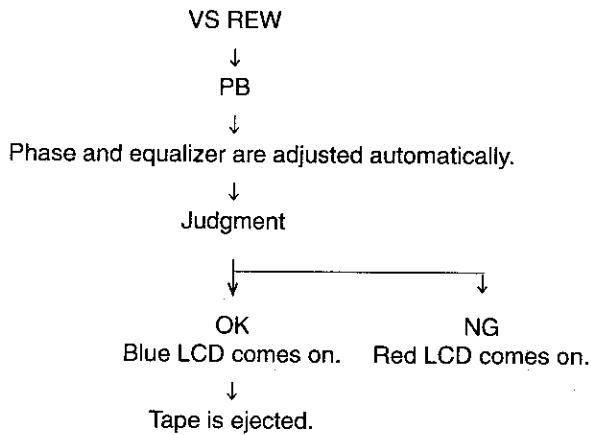

- 4) Error rate check
Select and fix the TEST MODE 0C on the adjustment remote control.
- 5) Manual adjustment method (video adjustment mode)
For phase, vary the data for the address 2B, and for equalizer, vary the data for the address 27, to set the error rate to the minimum.

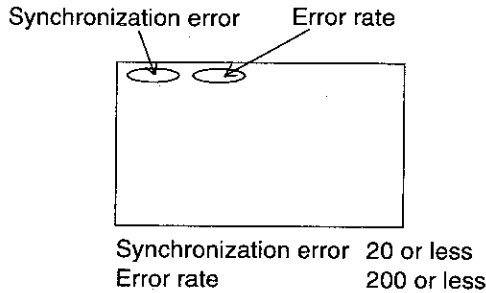

Adjusting the video I/O circuit system

(CIRCUIT BOARD DIAGRAM B)

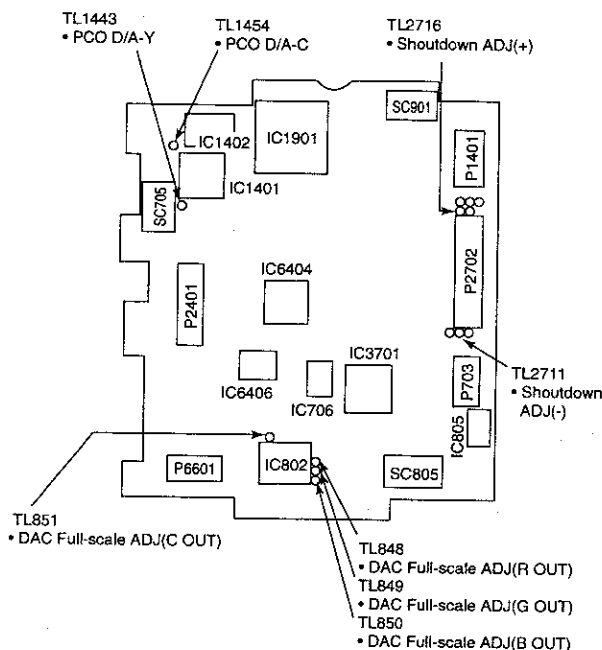

1. I/O filter adjustment

[Mode]

EE mode for colour bar input (video power side)

[Procedure]

- 1) Call the adjustment mode (V-ADJ).
- 2) Set the address to "21" and call the data.
- 3) Set the data to "70."

2. PCO D/A-Y adjustment

[Mode]

EE mode for any given video signal

[Test point]

TL1443 (connected to oscilloscope)

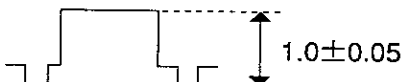

[Procedure]

- 1) Call the adjustment mode (V-ADJ).
- 2) Set the address to "22" and call the data.
(100% white signal is output.)
- 3) Vary the data with the FF and REW keys to set the signal appearing at TL1443 to 1.0 Vp-p ± 0.05.

* Data should be set within the range range is from 00 to 60.

3. PCO D/A-C adjustment

[Mode]

No input

[Test point]

TL1454

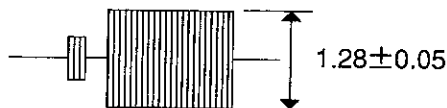

[Procedure]

- 1) Call the adjustment mode (V-ADJ).
- 2) Set the address to "23" and call the data.
- 3) Vary the data with the FF and REW keys to set the signal appearing at TL1454 to 1.28 Vp-p ± 0.05.

* Data should be set within the range from 00 to 60.

1) During E²PROM replacement

1) During E²PROM replacement

1) During E²PROM replacement

Adjusting the LCD circuit * To make this adjustment, set the backlight switch to the "NORMAL" position.

(CIRCUIT BOARD DIAGRAM D)

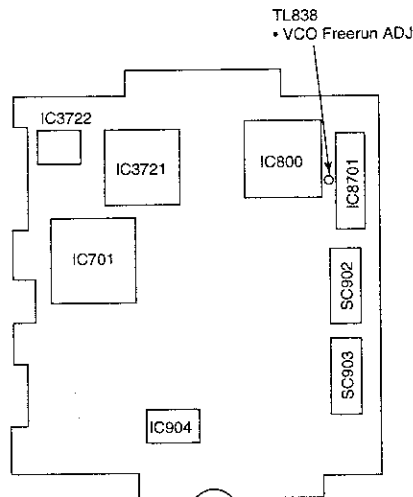

1. VCO free-run ADJ

[Mode]

VCR AV input or internal blue back picture

[Address]

VCR ADJ 32

[Measuring point]

TL838 (HSY)

[Adjustment rating]

625 KHz ± 100Hz

[Procedure]

- 1) Change the VCR ADJ address 57 from F7 to FB.
- 2) Connect the Frequency counter to TL838 and adjust it to the specified rating with the VCR ADJ address 32.
- 3) Set the VCR ADJ address 57 to F7.

Note: Setting the address 57 to F8/F9 turns off the LCD screen, but keep changing the data. Otherwise the original screen will not come on again. In such case, the address and the data cannot be checked on the LCD screen. To correct this, make sure the power switch is at the camera position, make connection between the AV pack's video output and the TV set, and check the data on the TV screen.

1) During IC706 (E²PROM) replacement

(CIRCUIT BOARD DIAGRAM B)

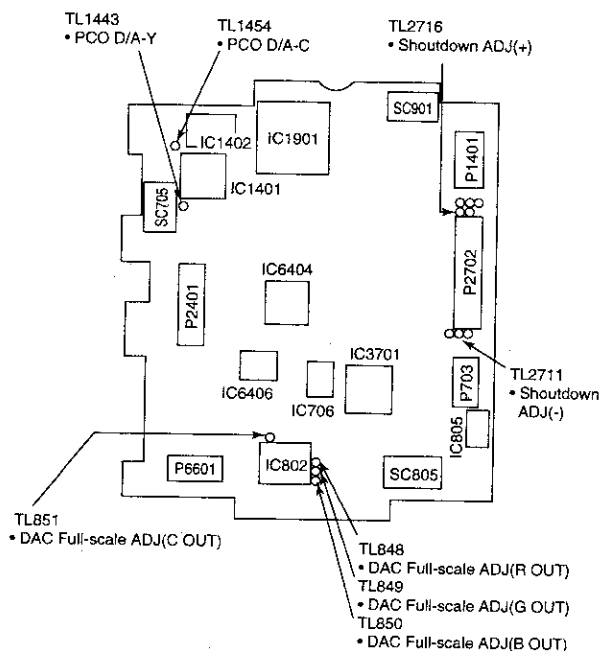

2. DAC full-scale ADJ

[Mode]

VCR AV input

[Addresses]

VCR ADJ 3E (R/G)

VCR ADJ 3D (B/C)

[Measuring points]

TL848 (R OUT)

TL849 (G OUT)

TL850 (B OUT)

TL851 (C OUT)

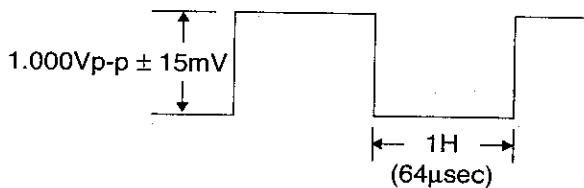

[Adjustment rating]

1.000 Vp-p ± 15 mV

[Procedure]

- 1) Change the VCR ADJ addresses 47, 49 and 64 to FE, 7F and 7F, respectively. (At this time, remember to take note of the data before changing them.)
- 2) With the VCR ADJ address 3E, set the TL848/849 output voltage to the adjustment rating, and with the synchronizer, set the peak voltage also to the adjustment rating, in such a way that the both TPs' voltages will be averaged into the rated mean value.
- 3) With the VCR ADJ address 3D, set the TL850/851 output voltage to the adjustment rating, and with the synchronizer, set the peak voltage also to the adjustment rating. (Same as in Step (2) above)
- 4) Set the changed address data back to normal.

Note: Setting each address data back to normal leaves the LCD screen white. At this time, turning off and on the main power will restore the screen (the lithium battery should be removed).

- 1) During IC706 (E²PROM) replacement
- 2) During IC800 replacement

3. COM-Bias ADJ

[Mode]

VCR AV input

[Address]

VCR ADJ 33

[Measuring point]

LCD panel display area

[Adjustment rating]

Minimum

[Procedure]

- 1) Feed 40% white signal to the AV input jacks.
- 2) Set the illumination meter (TOPCON IM-3) onto the LCD panel surface. (No external light is allowed to enter.)
- 3) Set the output wave form ripple on the illumination meter to the minimum level.



Response time: 0.6 sec

Or feed the gray-scale pattern signal and make the black portion blackest.

[Remarks]

Make this adjustment after 5-minute or longer aging.

4. W/B ADJ

[Mode]

VCR AV input

[Address]

VCR ADJ 30 (R)
VCR ADJ 31 (B)

[Measuring point]

LCD panel display area

[Adjustment rating]

Based on the standard monitor

[Procedure]

- 1) Feed 40% white signal to the AV input jacks and the standard monitor.
- 2) Adjust the tone of the colour with the VCR ADJ addresses 30 and 31 until it becomes the same as that of the standard monitor.

[Remarks]

Make this adjustment after 5-minute or longer aging.

- 1) During IC706 (E²PROM) replacement
- 2) During circuit board (Main) replacement
- 3) During LCD replacement
- 4) During IC800 replacement

- 1) During IC706 (E²PROM) replacement
- 2) During circuit board (Main) replacement
- 3) During LCD replacement
- 4) During IC800 replacement

9-2. Camera Section Adjustments

9-2-1. Camera section service

(1) Subjects, measuring instruments and jigs needed for camera section service and adjustments

- | | | |
|---------------------|---------------------------------|-------------------------------------|
| • Gray scale chart | • Illumination meter | • Remote control unit for servicing |
| • White chart | • Colour temperature meter | • DC power supplier |
| • Colour bar chart | • Colour video monitor | • Light box |
| • Oscilloscope | • Video output cable | • INF adjustment lens |
| • Digital voltmeter | • AC adaptor | • Halogen Light (2 pcs.) |
| • Vector scope | • Extension cables | |
| • Frequency counter | • Switch jig for adjustment use | |

(2) Standard connections diagram at time of camera service

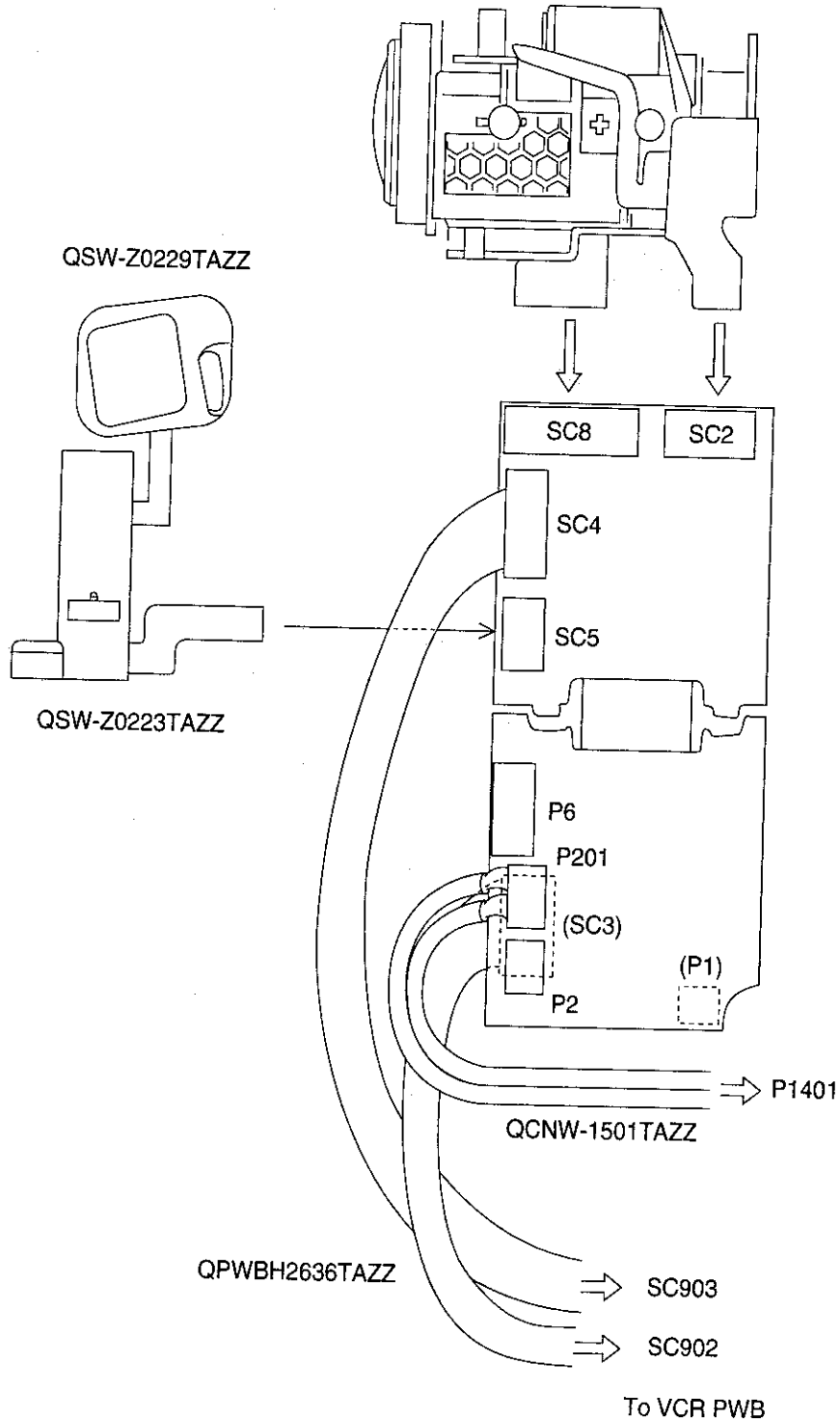

(3) Connections at the time of camera adjustment

When performing camera adjustments, remove the camera's front. Then connect connector P6 on the Camera CBA to the switch jig for adjustment use via a extension wire.

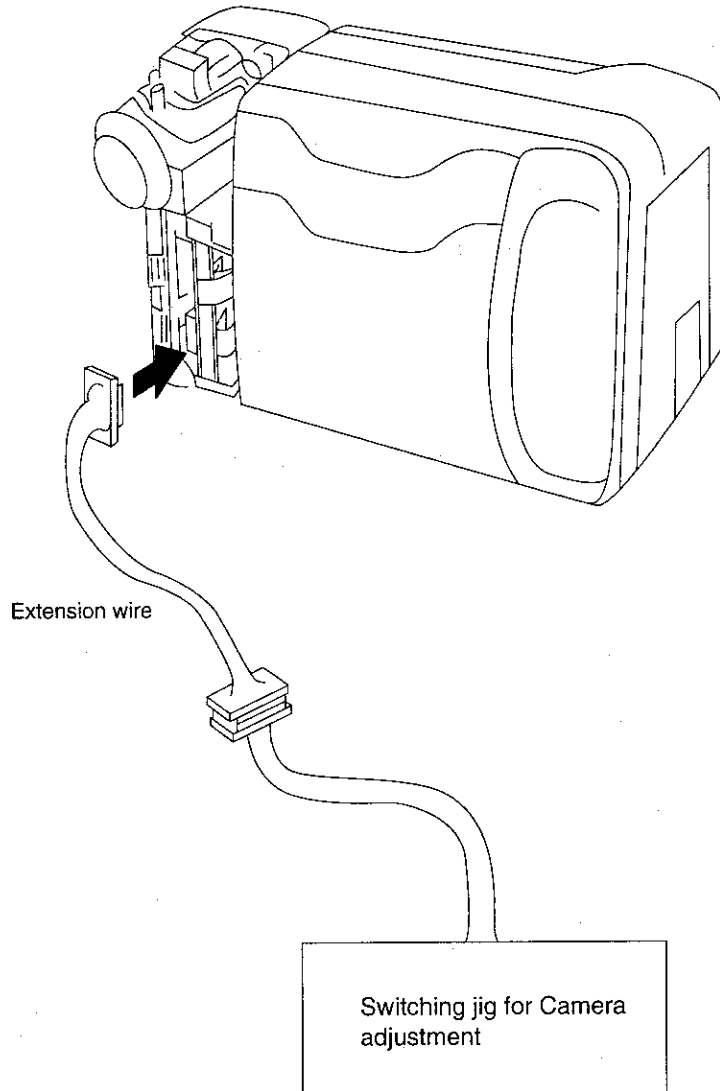

(4) Switch jig for camera section adjustments



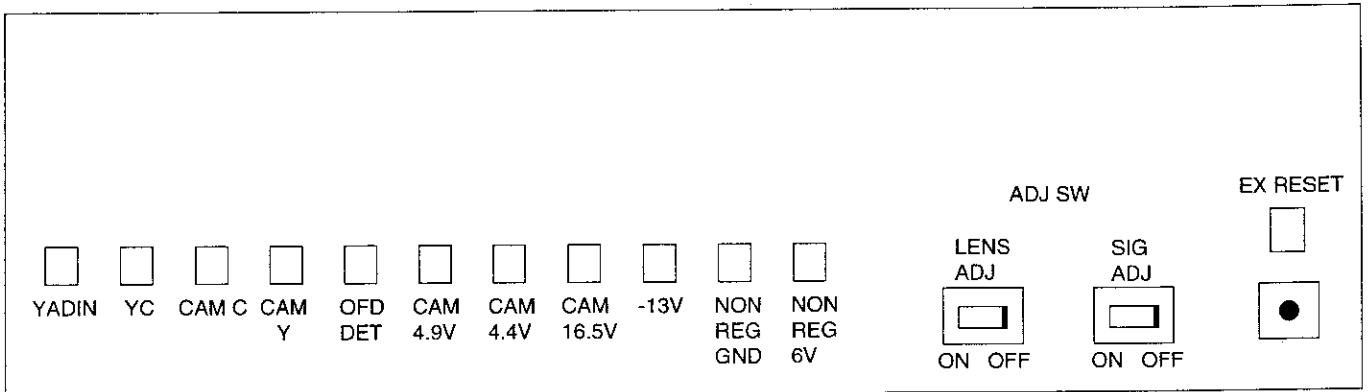

The jig is provided for switching for the purpose of waveform observation test point and camera signal system adjustments and zoom lens system auto focus adjustments during the camera adjustments. Note that a voltage is not output in all test points for a voltage. This is not a trouble, however.

All of the switches on the jig remain OFF during use.

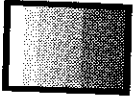

9-2-2. List of camera jigs and tools

Note: N indicates a new jig.

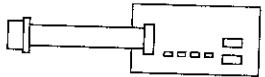
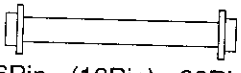
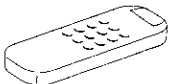
No.	Name of jig	Part code	Shape	Note
1	Gray scale chart (390 x 520mm)	JiGCHART-1		
2	Colour bar chart (240 x 320mm)	JiGCHART-4		
3	Illumination meter (0 to 3000 lux)	JiGMETER-1		
4	Colour temperature meter (1600 to 400000 degrees K)	JiGMETER-2		
5	Colour temperature conversion filter (3200 degrees K → 6800 degrees K)	JiGHOYA-LB165		
6	PC plate connector drawer	JiGTH-SS10		
7	Camera adjustment switch plate (QCNW-1220TAZZ)	QCNW-1220TAZZ		
8	Extension wire (camera adjustment switch plate ↔ P6)	QCNW-1368TAZZ	 26Pin (13Pin) 20Pin	N
9	Remote control unit for servicing	RRMCG0033TASA		

9-2-3. Adjusting the camera unit

(1) Preparations for adjustments and items to be checked

- 1) Set up the light box so that the entire pattern is evenly lit. Set the colour temperature to 3200°K.
- 2) Use test patterns that are not dirty nor discolored.
- 3) If the electrical circuitry gets in trouble, be sure to pinpoint the trouble spot with a measuring instrument and repair or replace the defective part.

(2) Remote control for servicing RRMCG0033TASA

To adjust the camera section of this machine, the remote control for servicing (RRMCG0033TASA) is used. The adjustment is made in such a manner that the remote control writes necessary data by way of the microprocessor to the specific addresses on the E²PROM (the ROM on the lens unit).

1) To adjust the camera:

Press the "CONTINUE" key first and then the "CAM ADJ" key.

This will show

CAM ADJ
□□□□

on the LCD screen, thereby having the camera unit ready for the adjustments.

2) Descriptions of the displays

CAM	ADJ	(Indicates the camera adjustment mode.)
□□□□	□□□□	
(Address value)	(Data value)	

* The address values for this machine range from 0000 to 02FF.

* The data include byte data (the last two digits are effective) and 2-byte data (the last three digits are effective).

3) Descriptions of the remote control keys

"FF" key: Increases the address and data values.

"REW" key: Decreases the address and data values.

"PLAY" key: Specifies addresses and calls the data.

This key also fixes (i.e., writes to the E²PROM) the data values.

"STOP" key: Clears the data to enable the selection of address.

4) Operation flow

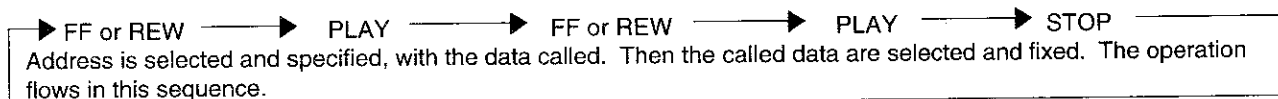

5) When the adjustment is complete:

Press the "CONTINUE" key to let the "CAM ADJ" display disappear from the screen.

Note: Before terminating the adjustments, make sure that the adjustment mode is neither the auto-focus function adjustment mode nor the camera signal system adjustment mode (these modes are mentioned later).

• Camera unit adjustment modes

The camera unit is adjusted in two types of modes: the auto-focus function adjustment mode and the camera signal system adjustment mode.

(3) Auto-focus function adjustment mode

- The camera unit uses a microprocessor-controlled zoom lens.

The auto-focus circuit incorporated in this unit is designed to execute the image processing where the focusing action is done by taking advantage of the fact that the high-frequency components in the image signals increase as the focus intensifies. Moreover, to achieve high magnifying power with a small lens, the camera unit incorporates the inner focus system in which the focus is shifted by moving the master lens (rear lens) back and forth. This inner focus system is a full-range focus type by which the focus can be shifted from approximately 10 mm to the infinity. It should be noted, however, that since the closest subject distance at the telephoto end is fixed at 1.5 mm, subjects in a closer range than 1.5 mm at the telephoto end will be out of focus. For this reason, the unit is designed so that the zoom control is automatically shifted to the wide angle side until the position is found where the subject can be focused on.

In the auto-focusing system of this unit, the following constitute the important factors:

- Master lens position detection data
- Iris position detection data
- Zoom lens position detection data

These detection data are handled and stored by the microprocessor, lens by lens, into the E²PROM.

Therefore, in the following cases, the auto-focus function adjustment is required:

- When the lens has been replaced
- When the CCD has been replaced
- When the E²PROM (located on the lens unit)

1) Shifting to the auto-focus function adjustment mode

Set the data for the address "02FE" to "□□□□01."



This makes the screen fade temporarily in white and shifts to the auto-focus function adjustment mode.

- * When this adjustment mode has been shifted to, make the adjustments according to (5) Camera unit adjustment procedure.
- * In this adjustment mode, the lens can not be operated.

2) Shifting to the normal operation mode

Set the data for the address "02FE" to "□□□□FF."



This makes the screen fade temporarily in white and shifts to the normal operation mode.



Press the "CONTINUE" key, and the "CAM ADJ" display goes out of the screen, enabling the normal operation.

(4) Camera signal system adjustment mode

In the camera signal system adjustment mode, the automatic white balance is disabled to allow for the adjustment of the camera unit. At this time, the white balance mode is fixed at the INDOORS mode and the focus mode is switched to the manual focus mode.

1) Shifting to the camera signal system adjustment mode

Set the data for the address "02FE" to "□□□□00."



This shifts the mode to the auto-focus function adjustment mode.

- * When this adjustment mode has been shifted to, make the adjustments according to (5) Camera unit adjustment procedure.

2) Shifting to the normal operation mode

Set the data for the address "02FE" to "FF"



This shifts the mode to the normal operation mode.



Press the "CONTINUE" key, and the "CAM ADJ" display goes out of the screen, enabling the normal operation.

(5) Camera unit adjustment procedure

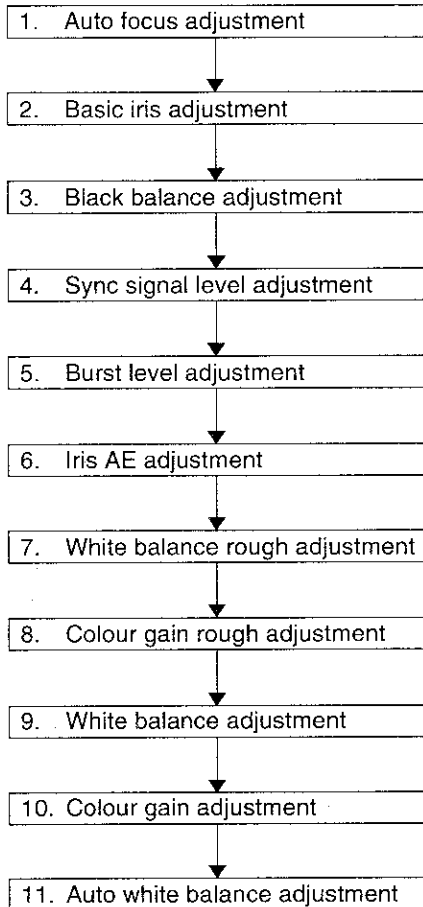



* The above 1. Auto-focus function adjustment and 2. Iris basic adjustment are performed in the auto-focus function adjustment mode, whereas the other adjustments are made in the camera signal system adjustment mode.

9-2-4. Adjustment procedures

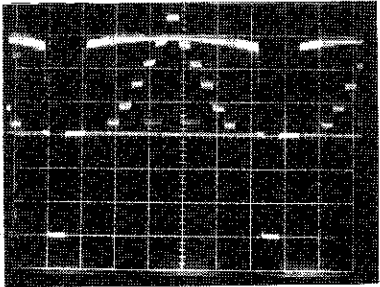
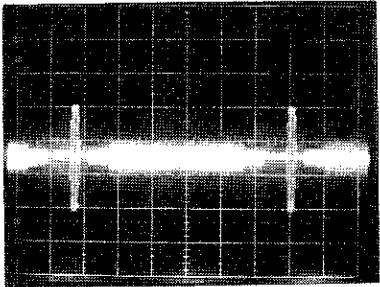
Item	Adjustment procedure										
(1) Auto focus adjustment	<p>Set the unit to the auto-focus function adjustment mode and write data to the address "02FF" one after another. This executes the adjustments automatically. The items to be adjusted are as listed below. Every time an adjustment is made properly, the data "FF" is written to the address. After each adjustment, make sure that the adjustment has been made properly, and then go on to the next adjustment item.</p> <table border="1" data-bbox="660 479 1365 607"> <thead> <tr> <th>Address</th> <th>Data</th> <th>Adjustment item</th> </tr> </thead> <tbody> <tr> <td rowspan="3">02FF</td> <td>000C</td> <td>Linearity adjustment</td> </tr> <tr> <td>0006</td> <td>WIDE end focus ∞ position adjustment</td> </tr> <tr> <td>0008</td> <td>TELE end focus ∞ position adjustment</td> </tr> </tbody> </table> <p>Note 1: To adjustment of ∞ position is executed by actually picking up the image of subject. For this adjustment use the subject with clear profile. Especially, if the adjustment of TELE end focus ∞ position is made without picking up the image of remote subject, adjustment failure may occur.</p> <p style="padding-left: 40px;">Adjustment of WIDE end focus ∞ position: 3 m or more Adjustment of TELE end focus ∞ position: 50 m or more</p> <p>Note 2: In case of ∞ position adjustment the field depth is important to ensure the adjustment accuracy. If the field depth is high, the focus becomes too stable, which may cause incorrect adjustment of ∞ position. Therefore the adjustment must be made with low field depth (with iris opened).</p> <p>Iris can be released through the use of a high-speed shutter, in the following manner.</p> <ol style="list-style-type: none"> 1. Return to the normal operation mode. 2. Click the high-speed shutter in the normal operation mode until the iris is released. (See the instruction manual.) 3. Display "CMA ADJ" in the screen with the remote control for servicing. 4. Shift to the auto-focus function adjustment mode. 5. Make the ∞ position adjustments. 6. After the adjustments, return the high-speed shutter to the normal mode. 	Address	Data	Adjustment item	02FF	000C	Linearity adjustment	0006	WIDE end focus ∞ position adjustment	0008	TELE end focus ∞ position adjustment
Address	Data	Adjustment item									
02FF	000C	Linearity adjustment									
	0006	WIDE end focus ∞ position adjustment									
	0008	TELE end focus ∞ position adjustment									
(2) Iris basic adjustment	<p>This is for adjusting the operating point of the hole element installed in the iris meter of the lens.</p> <p>Set the unit to the auto-focus function adjustment mode and write data to the address "02FF" one after another. This executes the adjustments automatically. The items to be adjusted are as listed below. Every time an adjustment is made properly, the data "00FF" is written to the address.</p> <table border="1" data-bbox="707 1473 1412 1601"> <thead> <tr> <th>Address</th> <th>Data</th> <th>Adjustment item</th> </tr> </thead> <tbody> <tr> <td rowspan="3">02FF</td> <td>0009</td> <td>Hall offset adjustment</td> </tr> <tr> <td>000A</td> <td>Iris offset adjustment</td> </tr> <tr> <td>000B</td> <td>Iris close adjustment</td> </tr> </tbody> </table>	Address	Data	Adjustment item	02FF	0009	Hall offset adjustment	000A	Iris offset adjustment	000B	Iris close adjustment
Address	Data	Adjustment item									
02FF	0009	Hall offset adjustment									
	000A	Iris offset adjustment									
	000B	Iris close adjustment									

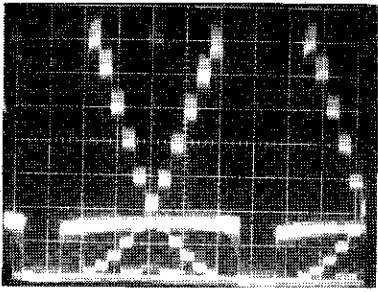
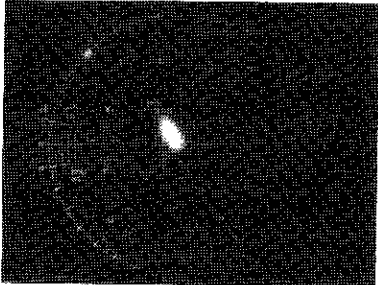
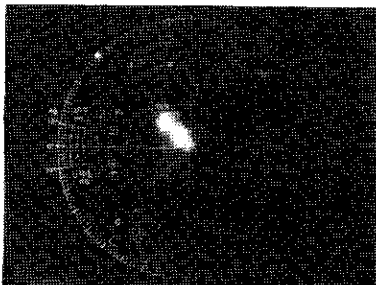
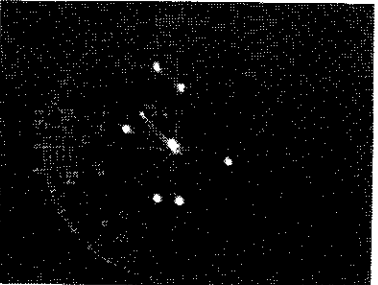
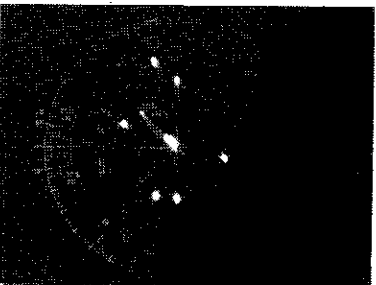
Item	Adjustment procedure														
<p>(3) Black balance adjustment</p>	<p>1) Prior to the adjustment, initialize the data for the addresses "01E4" thru "01E9." Write "□□□□FF" (the last two digits are effective) to all of these addresses.</p> <p>2) In the camera signal system adjustment mode (the data "□□□□00" is written to the address "02FE), write the data "□□□□01" to the address "02FF" This starts the adjustment automatically. When the adjustment is completed properly, the data "00FF" is written automatically.</p> <p>3) Calculate the data.</p> <table border="1" data-bbox="725 510 1282 730"> <thead> <tr> <th>Address</th> <th>Processing</th> </tr> </thead> <tbody> <tr> <td>01E4</td> <td>Written data minus 03 (subtraction)</td> </tr> <tr> <td>01E5</td> <td>Written data minus 03 (subtraction)</td> </tr> <tr> <td>01E6</td> <td>Written data minus 08 (subtraction)</td> </tr> <tr> <td>01E7</td> <td>Written data minus 02 (subtraction)</td> </tr> <tr> <td>01E8</td> <td>Written data minus 05 (subtraction)</td> </tr> <tr> <td>01E9</td> <td>Written data minus 09 (subtraction)</td> </tr> </tbody> </table>	Address	Processing	01E4	Written data minus 03 (subtraction)	01E5	Written data minus 03 (subtraction)	01E6	Written data minus 08 (subtraction)	01E7	Written data minus 02 (subtraction)	01E8	Written data minus 05 (subtraction)	01E9	Written data minus 09 (subtraction)
Address	Processing														
01E4	Written data minus 03 (subtraction)														
01E5	Written data minus 03 (subtraction)														
01E6	Written data minus 08 (subtraction)														
01E7	Written data minus 02 (subtraction)														
01E8	Written data minus 05 (subtraction)														
01E9	Written data minus 09 (subtraction)														
<p>(4) Synch signal level adjustment</p> <p>Measurement terminal: CAM Y Address : "01F8" YGAIN_CAM Measuring instrument : Oscilloscope (horizontal cycle) Subject : Anything. Variable data width range : "0000" - "00FE"</p>	<p>1) With the lens shaded, observe the video output with the oscilloscope, and rewrite the data for the address "01F8" so that the SYNCH level will be adjusted to 300 ± 10 m Vp-p.</p> <p>Note: When changing the data, the screen may get distorted. This is no trouble.</p> 														
<p>(5) Burst level adjustment</p> <p>Measurement terminal: CAM C. Address : "01F9" CGAIN_CAM Measuring instrument : Oscilloscope (horizontal cycle) Subject : Anything Variable data width range : "0000" - "00FE"</p>	<p>1) Observe the video output with the oscilloscope, and rewrite the data for the address "01F9" so that the burst level will be adjusted to 300 ± 20 m Vp-p.</p> 														

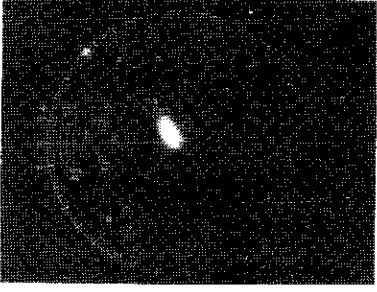
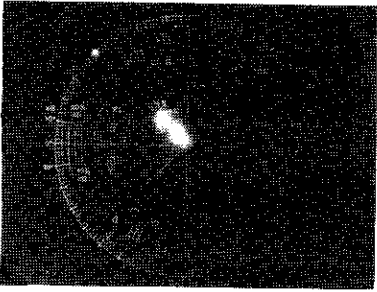
Item	Adjustment procedure																				
<p>(6) Iris AE adjustment</p> <p>Measurement terminal: Y-ADIN Address : "02FD" AE_CVT Measuring instrument : Oscilloscope (horizontal cycle) Subject : Gray scale Variable data width range : "0000" - "00FE"</p>	<p>1) With the unit set in the standard gray scale shooting mode, observe the video output with the oscilloscope, and rewrite the data for the address "02FD" so that the brightness signal level will be 700 ± 20 m Vp-p.</p> 																				
<p>(7) White balance rough adjustment</p> <p>Measurement terminal: EE OUT Address : "0010" INDOOR_R "0012" INDOOR_B Measuring instrument : Vector scope Subject : White chart Variable data width range : "0000" - "03FF"</p>	<p>1) Shoot the white chart, and adjust the zoom position so that the brightness level be as flat as possible. 2) Modify the data of addresses 0010 and 0012 so that the bright spot on the vector scope screen be 10% (VL-DC1E), 20% (VL-DC1H/S) along the R-Y axis and -10% (VL-DC1E), -20% (VL-DC1H/S) along the B-Y axis in the burst ratio.</p> <div style="display: flex; justify-content: space-around;"> <div style="text-align: center;"> <p>VL-DC1E</p>  </div> <div style="text-align: center;"> <p>VL-DC1H/S</p>  </div> </div>																				
<p>(8) Colour gain rough adjustment</p> <p>Measurement terminal: EE OUT Address : "0106N" RYG "0104" CGIN BYG "0102" CMAT RYG "0100" CMAT BYG Measuring instrument : Vector scope Subject : Colour bar chart Variable data width range : "0000" - "007F"</p>	<p>1) Shoot the colour bar chart and adjust the view angle so that the white level be 600mV. Observe the chart on the vector scope screen. Rewrite the data of addresses 106, 104, 100 and 102 so that the red and blue bright spots be as specified below. (The burst gain must be set at the 75% amplitude along the B-Y axis on the vector scope screen.)</p> <div style="display: flex; justify-content: space-around;"> <div style="text-align: center;"> <p>VL-DC1E</p>  </div> <div style="text-align: center;"> <p>VL-DC1H/S</p>  </div> </div> <table border="1" data-bbox="655 1832 1459 2011"> <thead> <tr> <th></th> <th>VL-DC1E</th> <th>VL-DC1H/S</th> <th>Adjustment address</th> </tr> </thead> <tbody> <tr> <td>Red amplitude</td> <td>1.75 ± 0.1 (burst ratio)</td> <td>1.85 ± 0.1 (burst ratio)</td> <td>"0106"</td> </tr> <tr> <td>Blue amplitude</td> <td>1.05 ± 0.1 (burst ratio)</td> <td>1.00 ± 0.1 (burst ratio)</td> <td>"0104"</td> </tr> <tr> <td>Red phase</td> <td>$104^\circ \pm 2^\circ$</td> <td>$105^\circ \pm 2^\circ$</td> <td>"0100"</td> </tr> <tr> <td>Blue phase</td> <td>$345^\circ \pm 2^\circ$</td> <td>$347^\circ \pm 2^\circ$</td> <td>"0102"</td> </tr> </tbody> </table>		VL-DC1E	VL-DC1H/S	Adjustment address	Red amplitude	1.75 ± 0.1 (burst ratio)	1.85 ± 0.1 (burst ratio)	"0106"	Blue amplitude	1.05 ± 0.1 (burst ratio)	1.00 ± 0.1 (burst ratio)	"0104"	Red phase	$104^\circ \pm 2^\circ$	$105^\circ \pm 2^\circ$	"0100"	Blue phase	$345^\circ \pm 2^\circ$	$347^\circ \pm 2^\circ$	"0102"
	VL-DC1E	VL-DC1H/S	Adjustment address																		
Red amplitude	1.75 ± 0.1 (burst ratio)	1.85 ± 0.1 (burst ratio)	"0106"																		
Blue amplitude	1.05 ± 0.1 (burst ratio)	1.00 ± 0.1 (burst ratio)	"0104"																		
Red phase	$104^\circ \pm 2^\circ$	$105^\circ \pm 2^\circ$	"0100"																		
Blue phase	$345^\circ \pm 2^\circ$	$347^\circ \pm 2^\circ$	"0102"																		

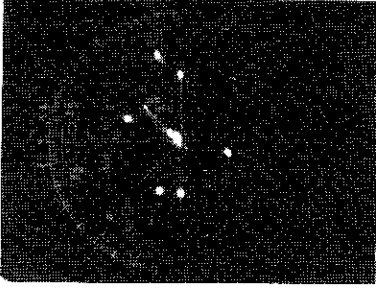
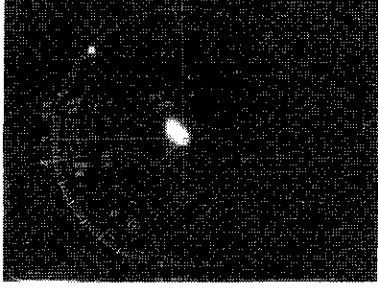
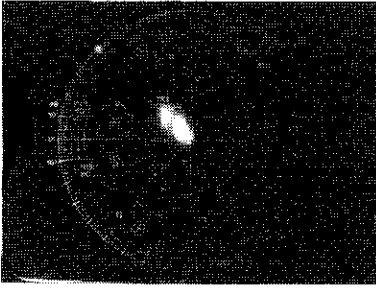
Item	Adjustment procedure															
<p>(9) White balance adjustment</p> <p>Measurement terminal: EE OUT Address : "0010" INDOOR R "0012" INDOOR B Measuring instrument : Vector scope Subject : Gray scale Variable data width range : "0000" - "03FF"</p>	<p>1) Repeat the white balance adjustment.</p> <div style="display: flex; justify-content: space-around;"> <div style="text-align: center;"> <p>VL-DC1E</p>  </div> <div style="text-align: center;"> <p>VL-DC1H/S</p>  </div> </div> <table border="1" style="margin: 10px auto;"> <thead> <tr> <th></th> <th>VL-DC1E</th> <th>VL-DC1H/S</th> </tr> </thead> <tbody> <tr> <td>R-Y</td> <td>10 ± 5 % (burst ratio)</td> <td>20 ± 0.1 (burst ratio)</td> </tr> <tr> <td>B-Y</td> <td>- 10 ± 5 % (burst ratio)</td> <td>- 20 ± 0.1 (burst ratio)</td> </tr> </tbody> </table>		VL-DC1E	VL-DC1H/S	R-Y	10 ± 5 % (burst ratio)	20 ± 0.1 (burst ratio)	B-Y	- 10 ± 5 % (burst ratio)	- 20 ± 0.1 (burst ratio)						
	VL-DC1E	VL-DC1H/S														
R-Y	10 ± 5 % (burst ratio)	20 ± 0.1 (burst ratio)														
B-Y	- 10 ± 5 % (burst ratio)	- 20 ± 0.1 (burst ratio)														
<p>(10) Colour gain adjustment</p> <p>Measurement terminal: EE OUT Address : "0106" CGIN RYG "0104" CGIN BYG "0102" CMAT RYG "0100" CMAT BYG Measuring instrument : Vector scope Subject : Colour bar chart on wave form monitor Variable data width range : "0000" - "003F"</p>	<p>1) Repeat the colour gain adjustment.</p> <div style="display: flex; justify-content: space-around;"> <div style="text-align: center;"> <p>VL-DC1E</p>  </div> <div style="text-align: center;"> <p>VL-DC1H/S</p>  </div> </div> <table border="1" style="margin: 10px auto;"> <thead> <tr> <th></th> <th>VL-DC1E</th> <th>VL-DC1H/S</th> </tr> </thead> <tbody> <tr> <td>Red amplitude</td> <td>1.75 ± 0.1 (burst ratio)</td> <td>1.85 ± 0.1 (burst ratio)</td> </tr> <tr> <td>Blue amplitude</td> <td>1.05 ± 0.1 (burst ratio)</td> <td>1.00 ± 0.1 (burst ratio)</td> </tr> <tr> <td>Red phase</td> <td>104° ± 2°</td> <td>105° ± 2°</td> </tr> <tr> <td>Blue phase</td> <td>345° ± 2°</td> <td>347° ± 2°</td> </tr> </tbody> </table>		VL-DC1E	VL-DC1H/S	Red amplitude	1.75 ± 0.1 (burst ratio)	1.85 ± 0.1 (burst ratio)	Blue amplitude	1.05 ± 0.1 (burst ratio)	1.00 ± 0.1 (burst ratio)	Red phase	104° ± 2°	105° ± 2°	Blue phase	345° ± 2°	347° ± 2°
	VL-DC1E	VL-DC1H/S														
Red amplitude	1.75 ± 0.1 (burst ratio)	1.85 ± 0.1 (burst ratio)														
Blue amplitude	1.05 ± 0.1 (burst ratio)	1.00 ± 0.1 (burst ratio)														
Red phase	104° ± 2°	105° ± 2°														
Blue phase	345° ± 2°	347° ± 2°														
<p>(11) Automatic white balance adjustment</p> <p>Measurement terminal: EE OUT Address : "0016" OUTDOOR R "0018" OUTDOOR B Measuring instrument : Vector scope Subject : Gray scale Variable data width range : "0000" - "03FF"</p>	<p>1) Attach the colour temperature conversion filter (LB165) to the lens. 2) Shoot the white chart, and adjust the zoom position so that the brightness level be as flat as possible. 3) Modify the data of addresses 0016 and 0018 to get ready for the outdoor white balance adjustment.</p> <table border="1" style="margin: 10px auto;"> <thead> <tr> <th></th> <th>VL-DC1E</th> <th>VL-DC1H/S</th> </tr> </thead> <tbody> <tr> <td>R-Y</td> <td>10 ± 5 % (burst ratio)</td> <td>20 ± 5 (burst ratio)</td> </tr> <tr> <td>B-Y</td> <td>- 10 ± 5 % (burst ratio)</td> <td>- 15 ± 5 (burst ratio)</td> </tr> </tbody> </table> <div style="display: flex; justify-content: space-around; margin-top: 10px;"> <div style="text-align: center;"> <p>VL-DC1E</p>  </div> <div style="text-align: center;"> <p>VL-DC1H/S</p>  </div> </div>		VL-DC1E	VL-DC1H/S	R-Y	10 ± 5 % (burst ratio)	20 ± 5 (burst ratio)	B-Y	- 10 ± 5 % (burst ratio)	- 15 ± 5 (burst ratio)						
	VL-DC1E	VL-DC1H/S														
R-Y	10 ± 5 % (burst ratio)	20 ± 5 (burst ratio)														
B-Y	- 10 ± 5 % (burst ratio)	- 15 ± 5 (burst ratio)														

After the adjustments are complete, set the unit back in the normal operation mode (i.e., write the data "□□FF" to the address "02FE.")

10. USEFUL TIPS (PROBLEMS DIFFER FROM THOSE FOUND ON VHS OR 8mm DECKS BECAUSE THE SIGNALS ARE DIGITALLY PROCESSED.)

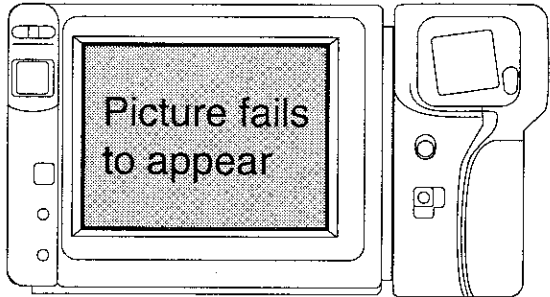
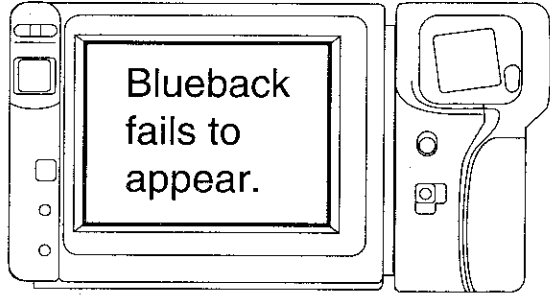
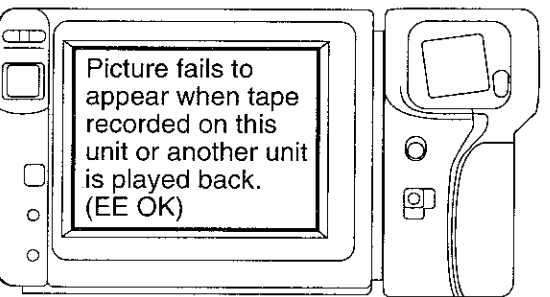
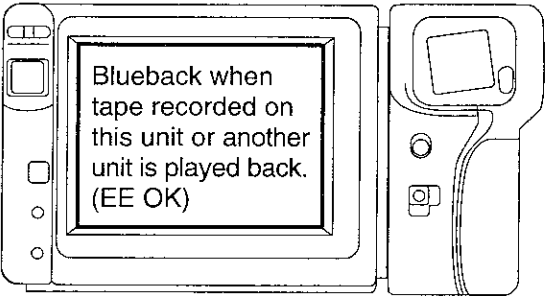
Problems	Major circuits to be checked
<p>Camera (EE mode)</p> 	<ul style="list-style-type: none"> • CCD • Camera circuits (CDS, ADC, DSP) • PCI (IC4401, IC4402) • PTC (IC4411) • LCD_DSP (IC800) • Gui microprocessor (IC3721)
<p>VCR (EE mode)</p> 	<ul style="list-style-type: none"> • PTC (IC4411) • Mechanical controller (IC702) • LCD_DSP (IC800) • Gui microprocessor (IC3721)
<p>Camera (REC mode) VCR (PB mode)</p> 	<ul style="list-style-type: none"> • PTC (IC4411) • CODEC 1 and 2 (IC401, IC411) • Transport 1 (IC405)
<p>Camera (REC mode) VCR (PB mode)</p> 	<ul style="list-style-type: none"> • Transport 2 (IC408) • PLL (IC3401) • ATF (IC3402) • Head amplifier (IC301) * Dirty or defective video head

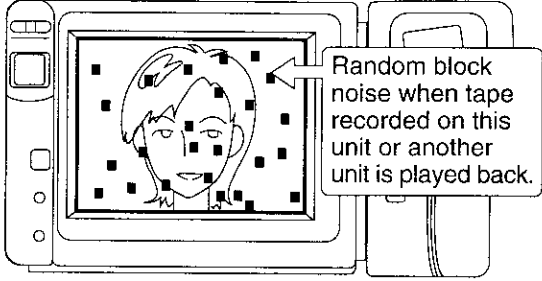
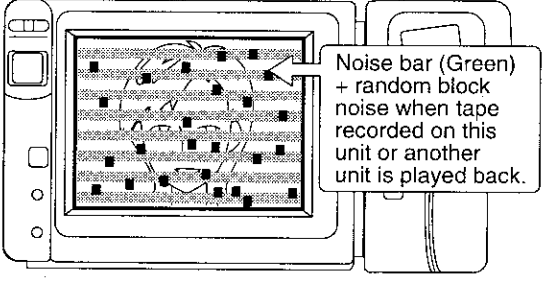
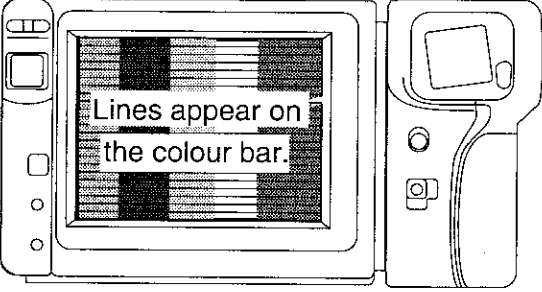
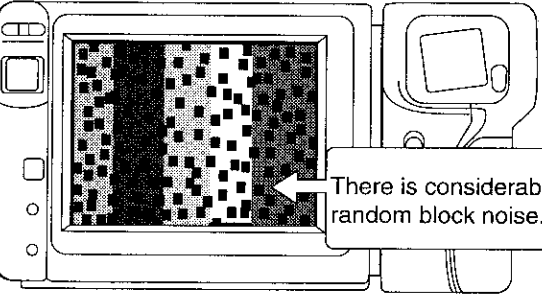
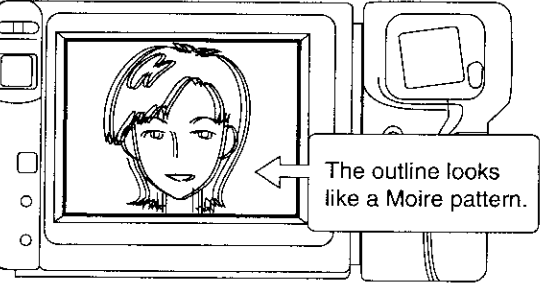
Problems	Major circuits to be checked
<p>Camera (REC mode) VCR (PB mode)</p>  <p>Random block noise when tape recorded on this unit or another unit is played back.</p>  <p>Noise bar (Green) + random block noise when tape recorded on this unit or another unit is played back.</p>	<ul style="list-style-type: none"> • Transport 2 (IC408) • PLL (IC3401) • ATF (IC3402) • Head amplifier (IC301) * Dirty or defective video head
<p>VCR (PB mode) + colour bar</p>  <p>Lines appear on the colour bar.</p>	<ul style="list-style-type: none"> • Data between CODEC 1 (IC401) and co-deck 2 (IC411) is missing.
<p>VCR (PB mode) + colour bar</p>  <p>There is considerable random block noise.</p>	<ul style="list-style-type: none"> • Data between CODEC 2 (IC411) and transport 1 (IC405) is missing.
<p>Camera (EE mode)</p>  <p>The outline looks like a Moire pattern.</p>	<ul style="list-style-type: none"> • Y data between camera DSP (IC201) and LCD_DSP (IC800) is missing.

11. SIGNAL FLOW DIAGRAM / SIGNALFLUSSDIAGRAMM
信号流程图

11-1. E-E MODE FLOW (VIDEO) /
FLUSSBILD DES E-E-MODUS (VIDEO)
E-E方式视频信号流程图

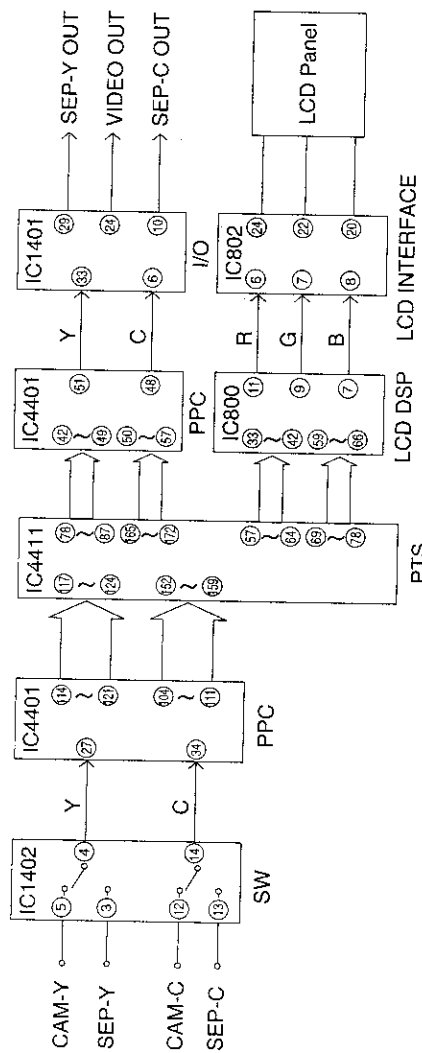

WAVEFORM DIAGRAM (DURING COLOUR BAR PLAYBACK) /
WELLENFORM-DIAGRAMM (WÄHREND DER FARBALKEN-WIEDERGABE)
波形图 (在播放彩条信号时)

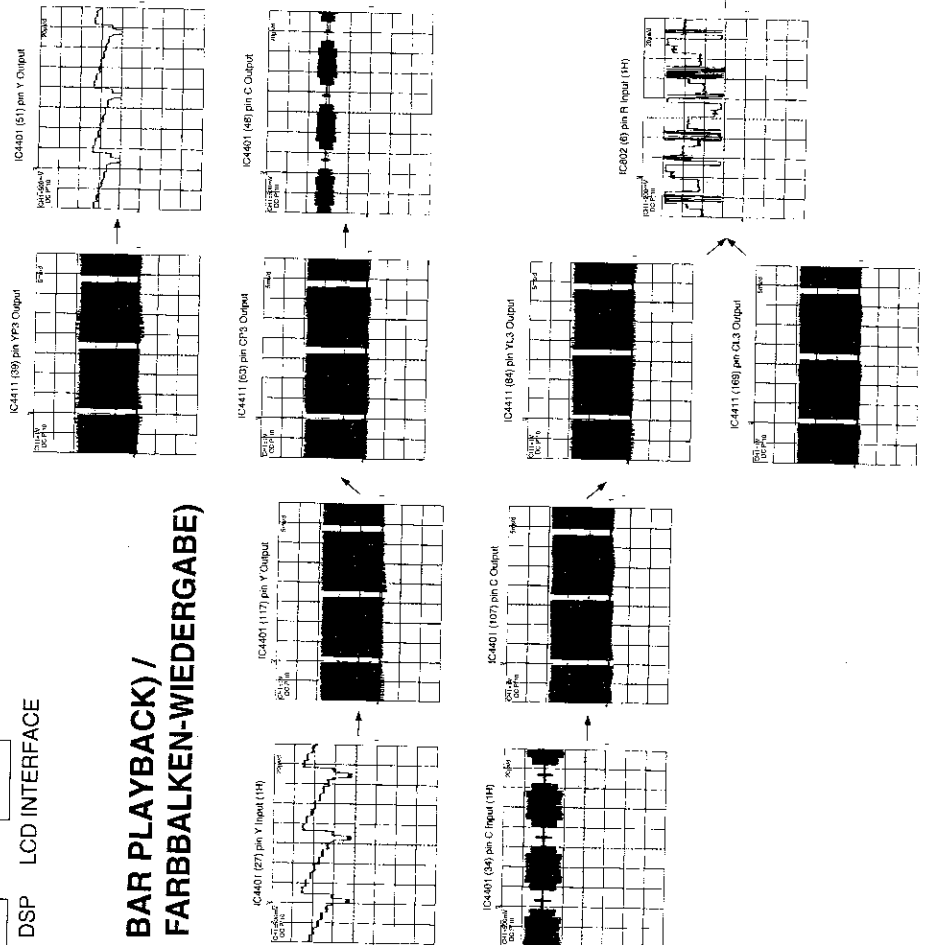

A B C D E F G H

1 2 3 4 5 6

**11-2. FLOW IN REC MODE (VIDEO) /
FLUSSBILD IM REC-MODUS (VIDEO)**
记录方式视频信号流程图

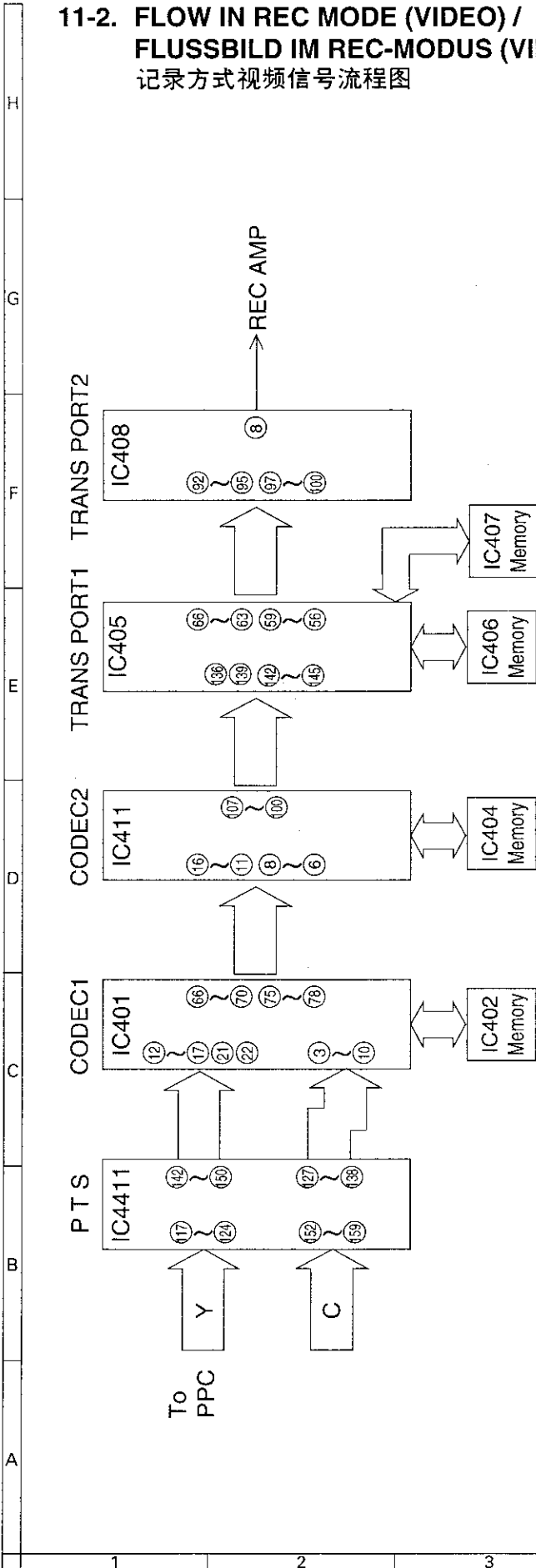

**WAVEFORM DIAGRAM (DURING COLOUR BAR RECORDING) /
WELLENFORM-DIAGRAMM (WÄHREND DER FARBBALKEN-AUFNAHME)**
波形图 (在记录彩条信号时)

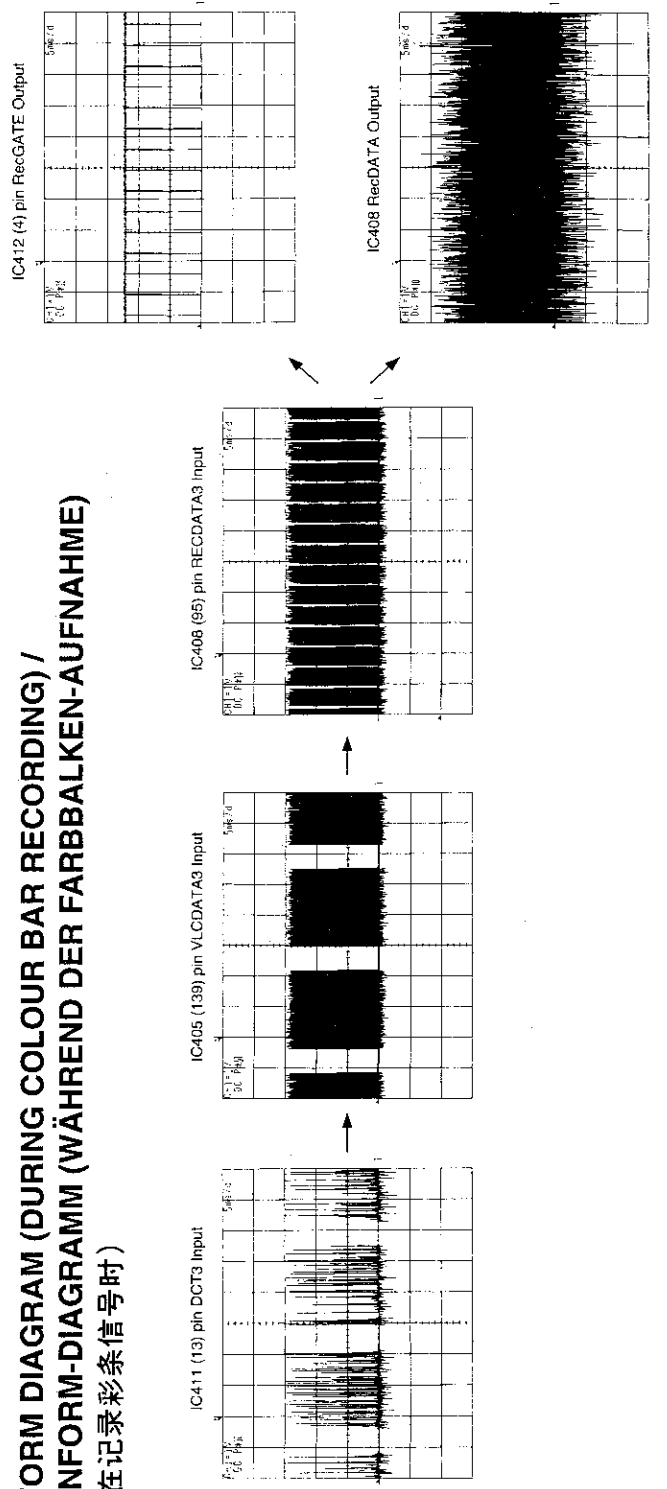

11-3. FLOW IN PB MODE (VIDEO) /
 FLUSSBILD IM PB-MODUS (VIDEO)
 演放方式视频信号流程图

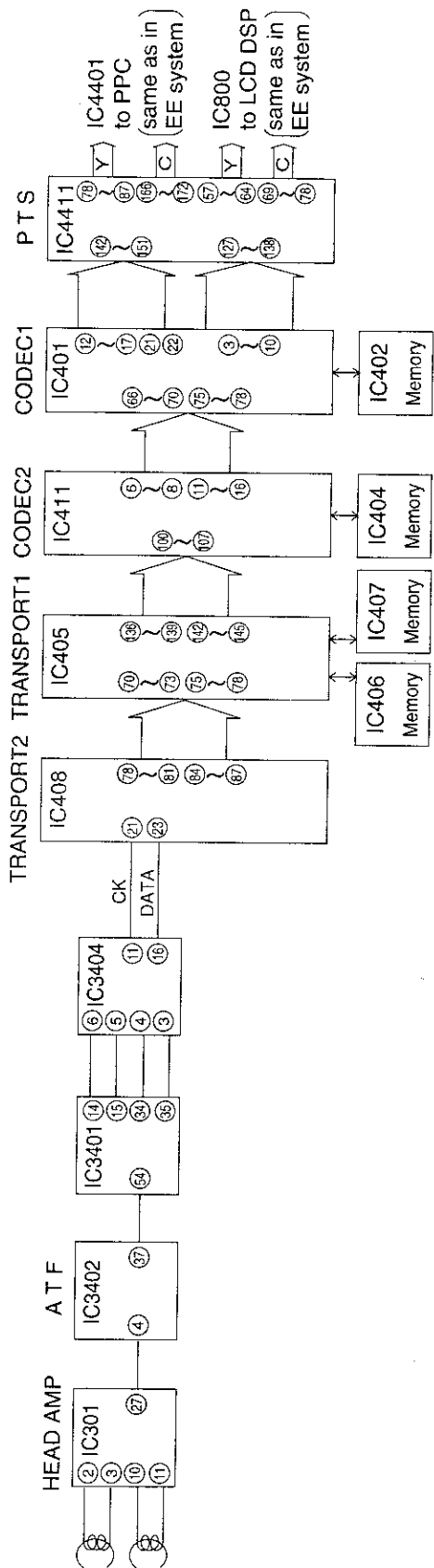

WAVEFORM DIAGRAM (DURING COLOUR BAR PLAYBACK) /
 WELLENFORM-DIAGRAMM (WÄHREND FARBBALKEN-WIEDERGABE)
 波形图 (在播放彩条信号时)

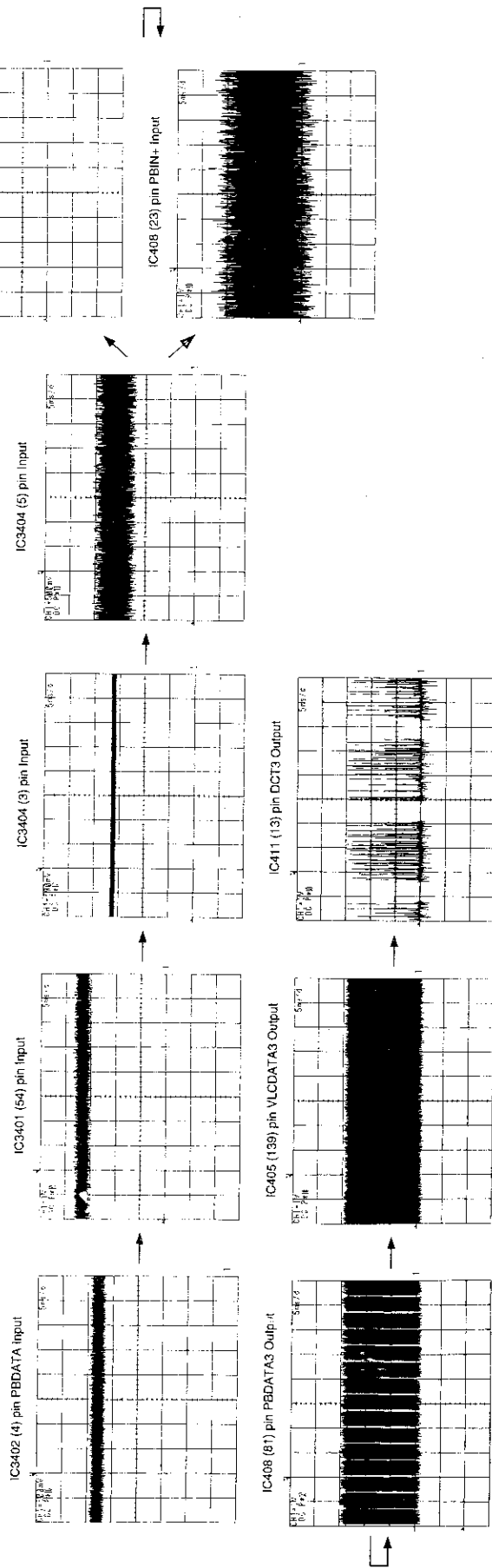

11-4. FLOW IN REC MODE (AUDIO) / FLUSSBILD IM REC-MODUS (AUDIO)
记录方式音频信号流程图

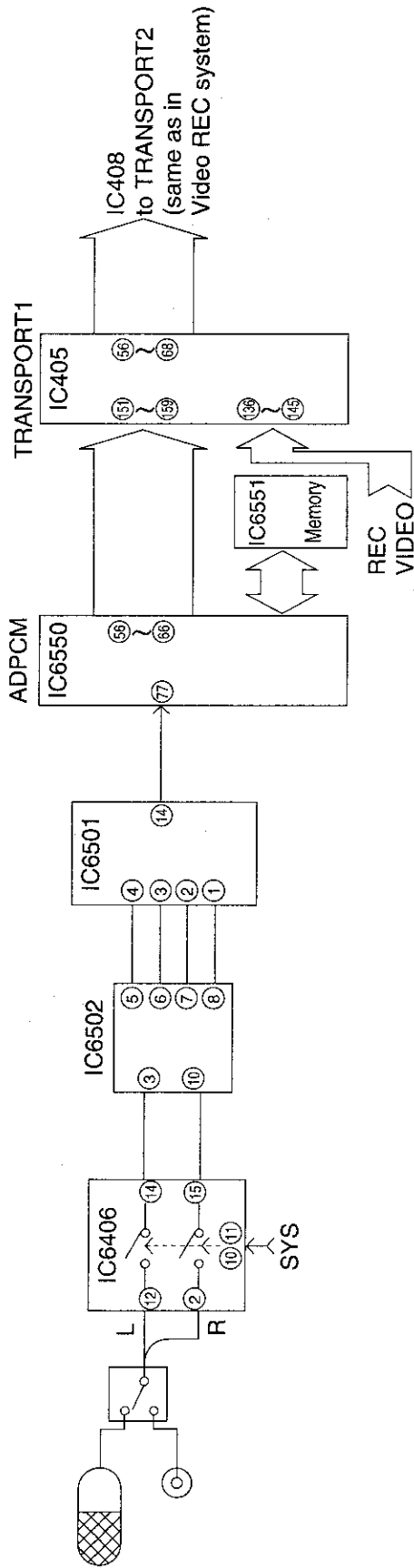

WAVEFORM DIAGRAM (1.6k Hz SINE WAVE) /
WELLENFORM-DIAGRAMM (1,6 kHz-SINUSWELLE)
波形图 (1.6kHz正弦波)

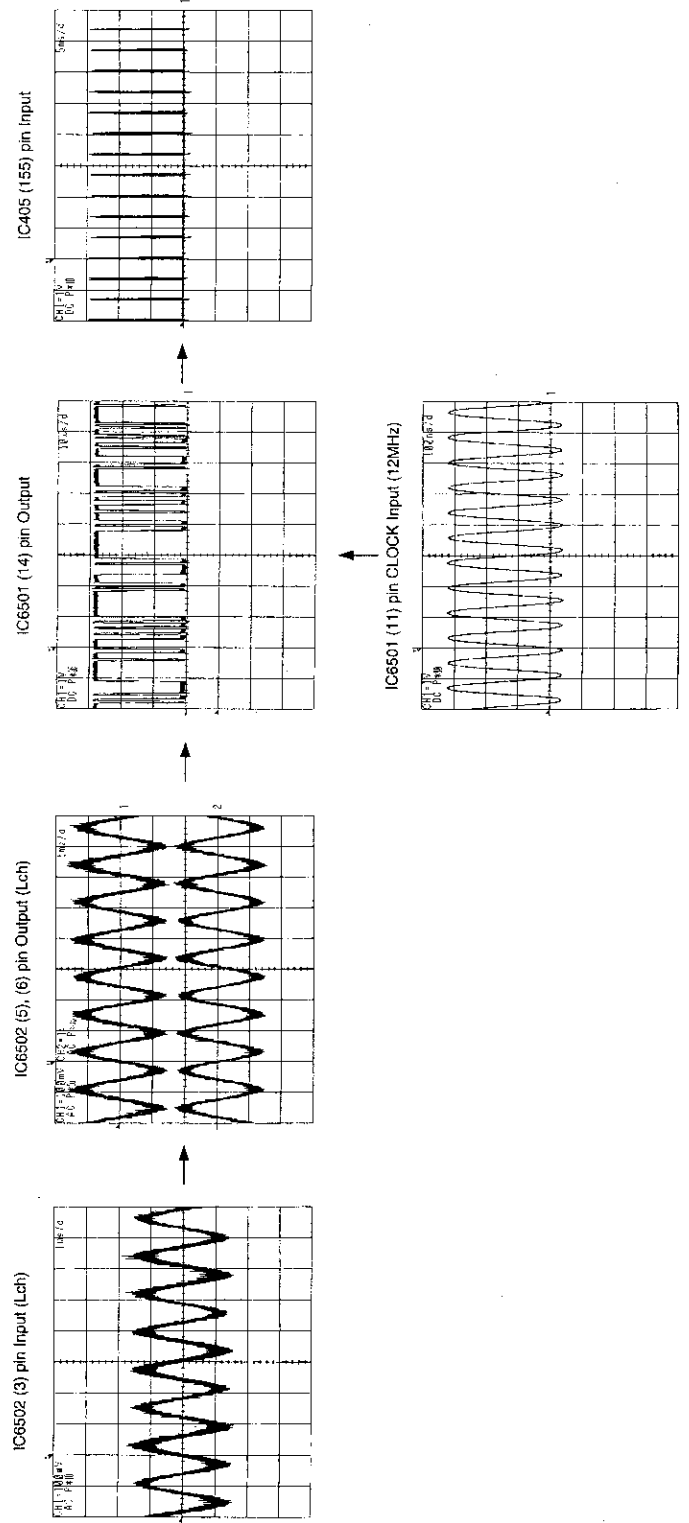

11-5. FLOW IN PB MODE (AUDIO) / FLUSSBILD IM PB-MODUS (AUDIO)

演奏方式音频信号流程图

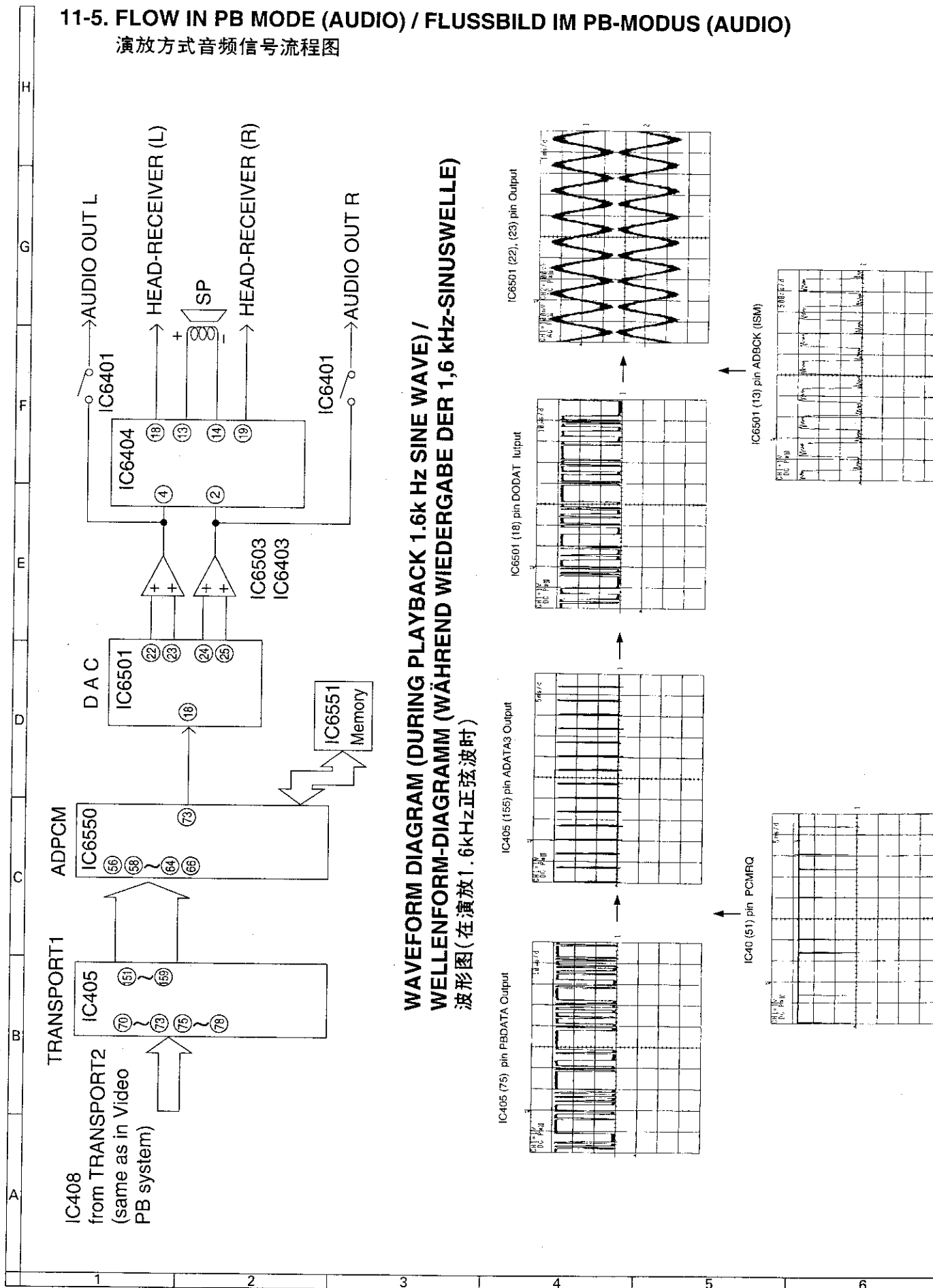

12. BLOCK DIAGRAM/BLOCKDIAGRAMM 系统方框图
 12-1. IC SYSTEM BLOCK DIAGRAM/IC-SYSTEMBLOCKDIAGRAMM
 集成电路系统方框图

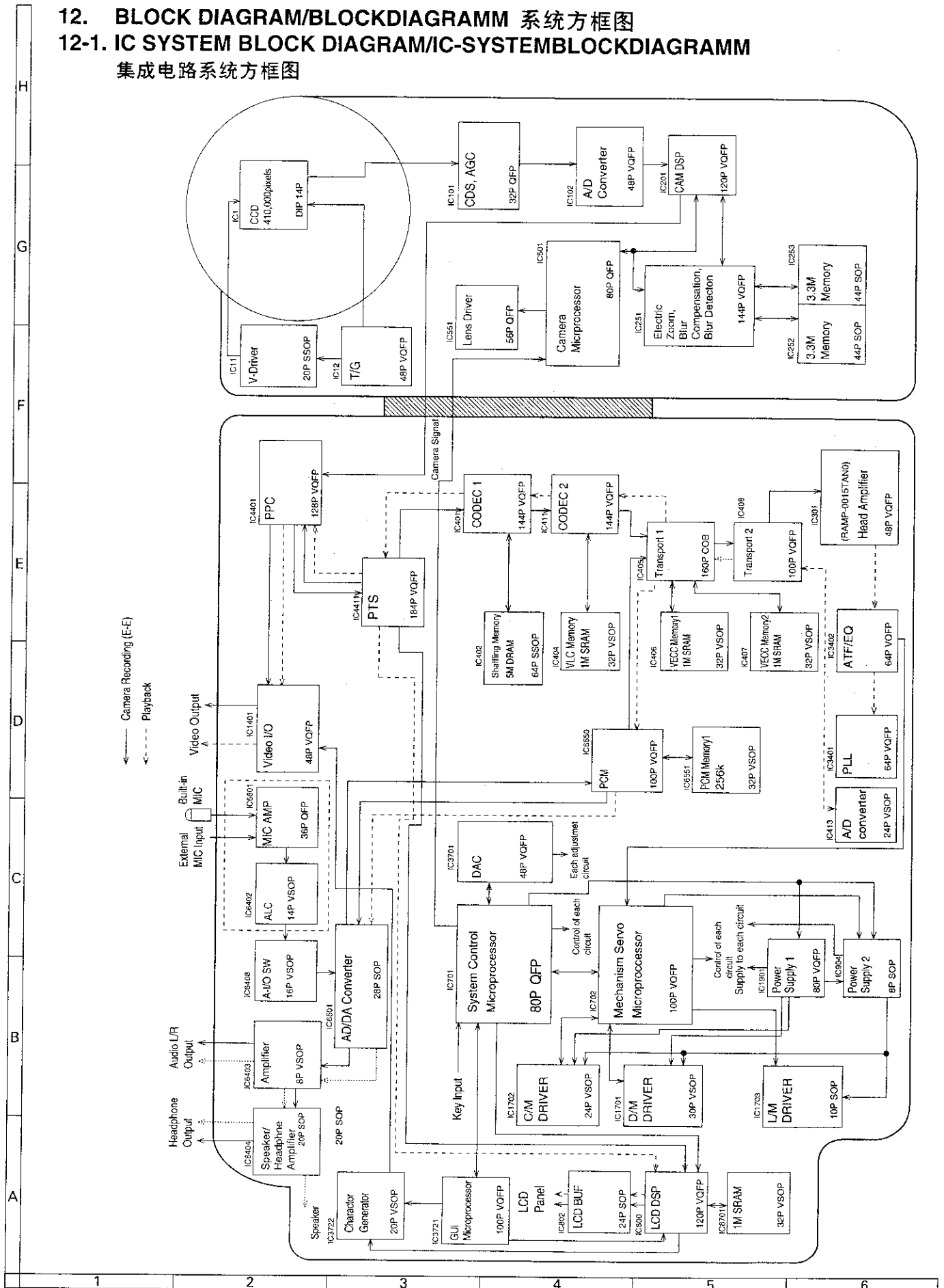

**12-2. VCR SECTION BLOCK DIAGRAM (during RECORDING) /
BLOCKDIAGRAMM DES VCR-BEREICHS (WÄHREND DER AUFNAHME)
录像机部分方框图(记录时)**

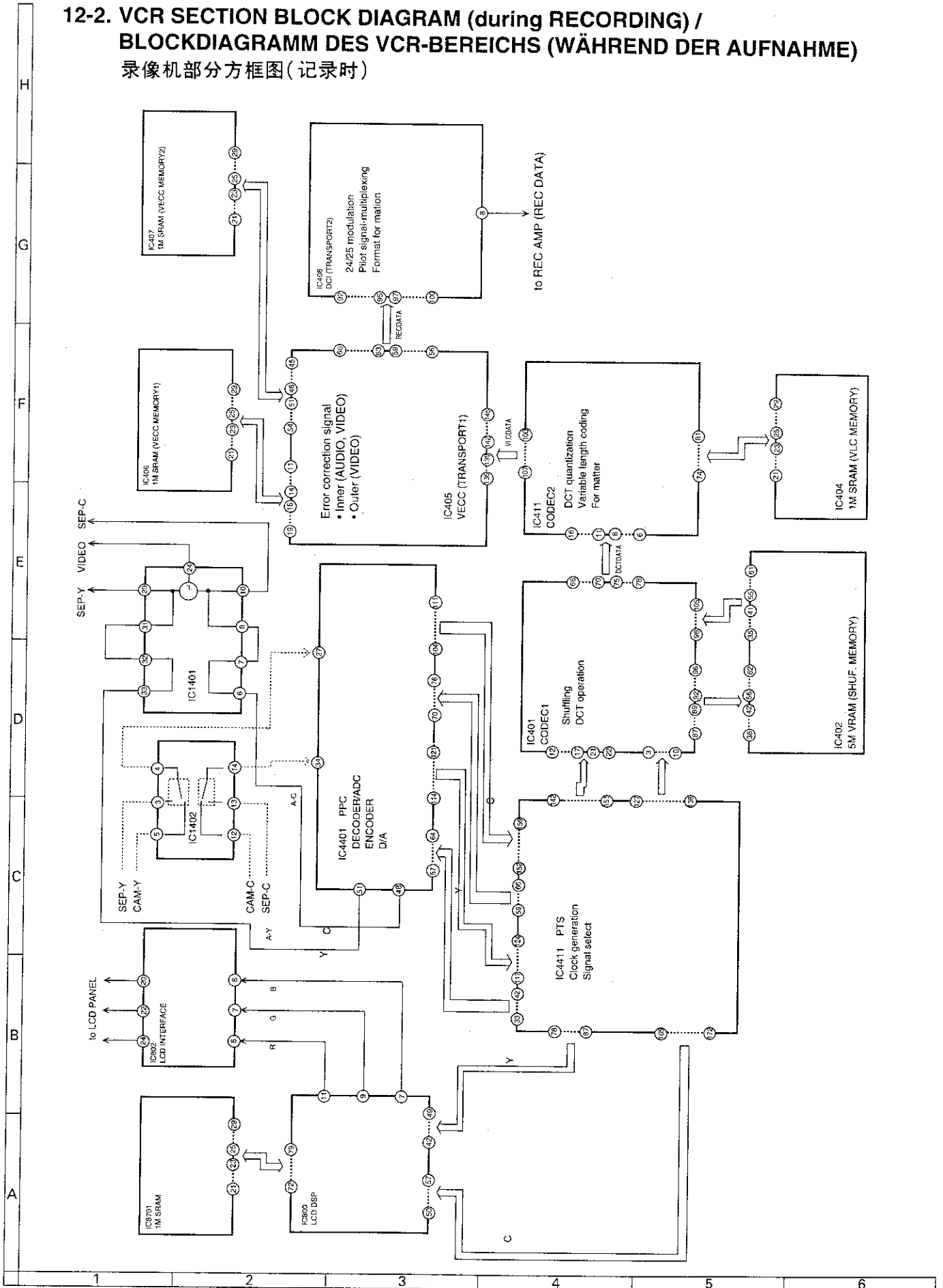

**12-3. VCR SECTION BLOCK DIAGRAM (during PLAYBACK) /
BLOCKDIAGRAMM DES VCR-BEREICHS (WÄHREND DER WIEDERGABE)
录像机部分方框图(播放时)**

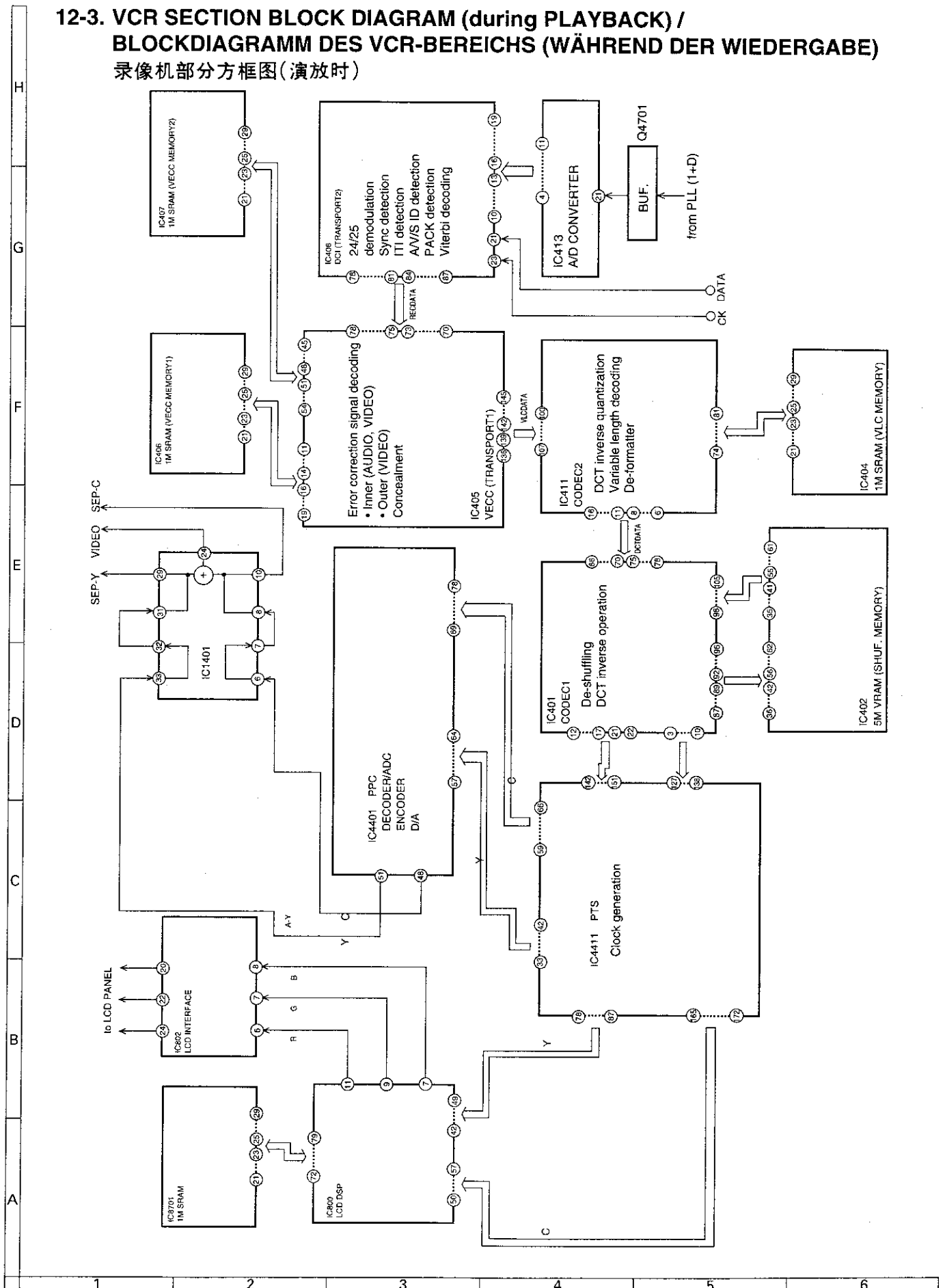

**12-4. AUDIO SECTION BLOCK DIAGRAM (during RECORDING/PLAYBACK AUDIO) /
BLOCKDIAGRAMM DES AUDIO-BEREICHS
(WÄHREND AUDIO-AUFNAHME/WIEDERGABE)
音响装置部分方框图(记录/演放音频信号时)**

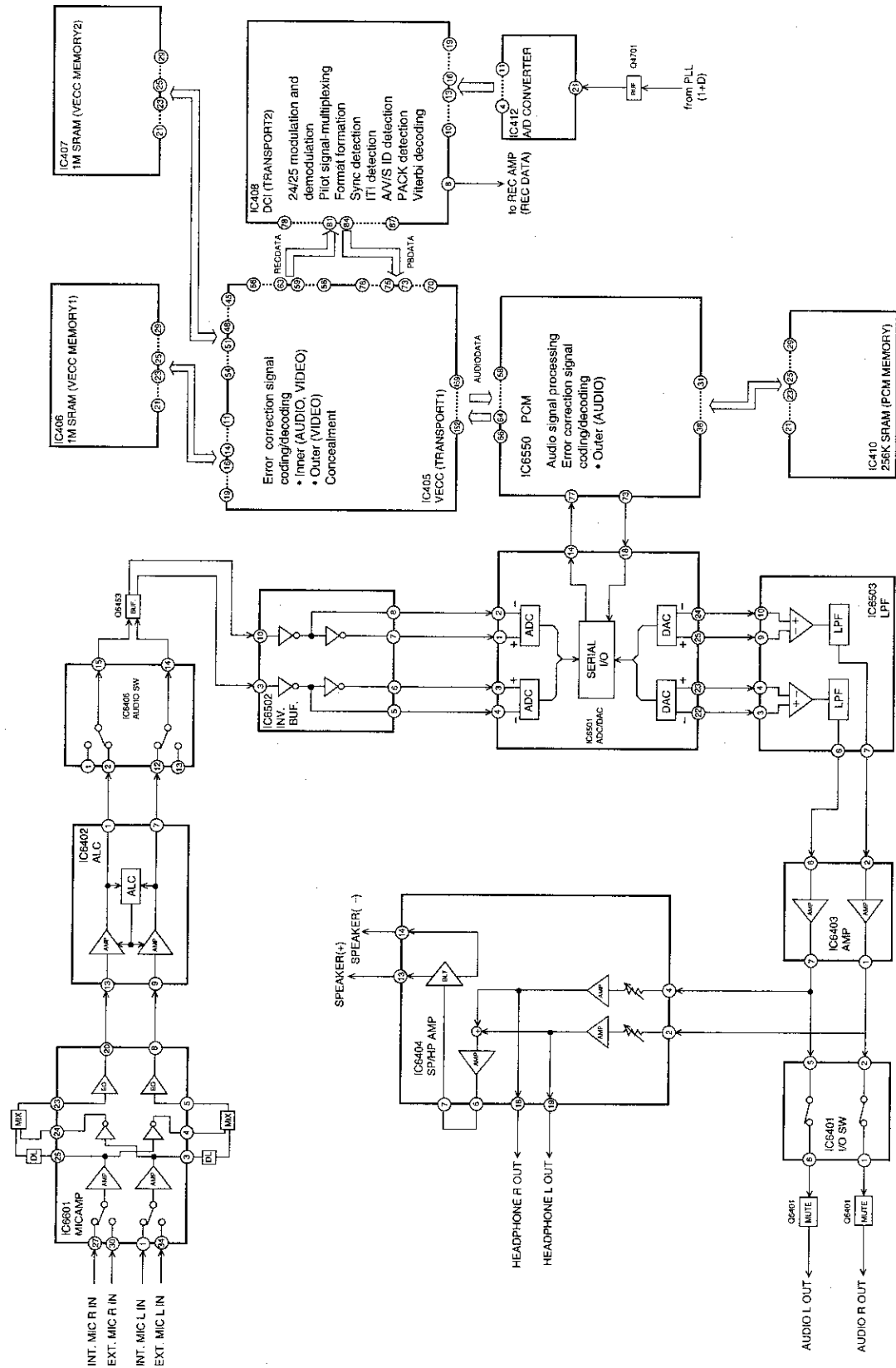

12-5. CAMERA CIRCUIT BLOCK DIAGRAM /
 BLOCKDIAGRAMM DES KAMERA-SCHALTKREISES
 摄影机电路方框图

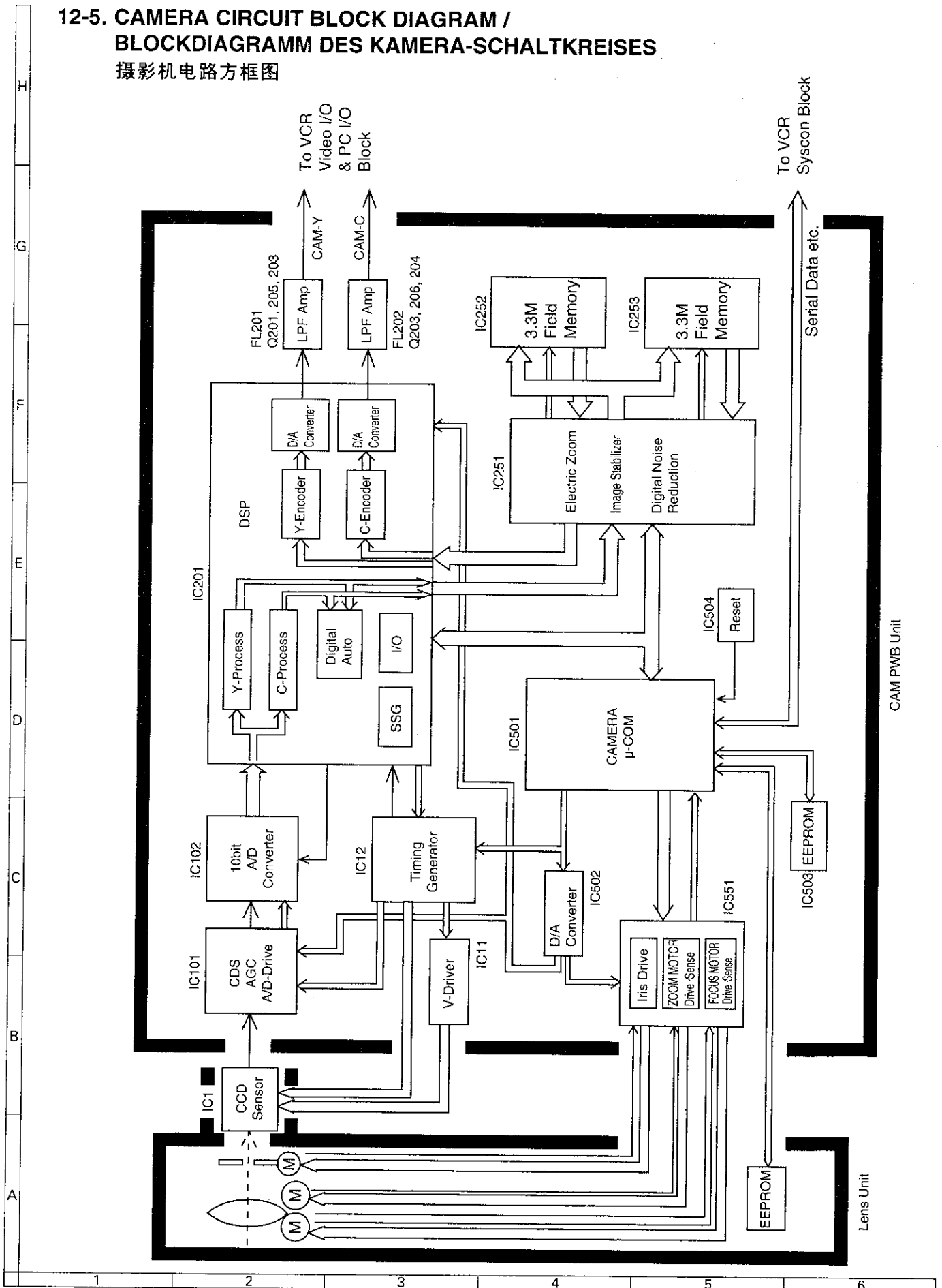

21. SEMICONDUCTOR LEAD IDENTIFICATION / IDENTIFIKATION DER HALBLEITER-KABELANSCHLÜSSE

半导体引脚的识别

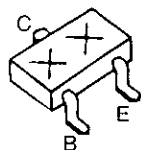

2SA1774F
2SB12956
2SD1979S
2SC4617B
2SC4738Y
2SD2216

2SC4627CD
2SB1197KQ
2SD1819A
DTC144EE
UN9111
UN9214

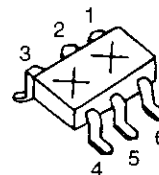

UMB2
UMD12N
UMT2
UMX2

UMZ1
XP6501
XP4311
HN1B01FU

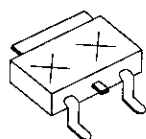

2SD1805

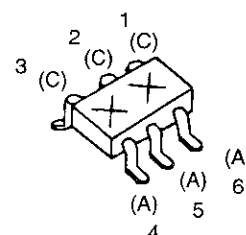

UMR11N

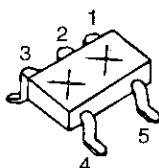

FMG12
UMG2
UMG5N
XP1B301
XP1213

NJM2107F
TA75S01F
TA75S393
TA75S558
TC7S08F

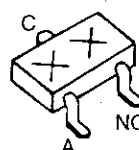

DA121

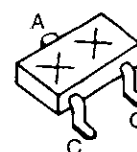

MA704WA

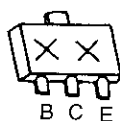

2SB1121T
2SB1302S
2SD1664R

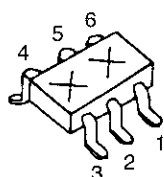

IMX9
XN4604

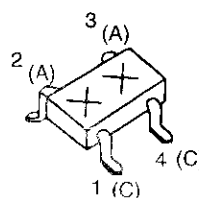

DA227

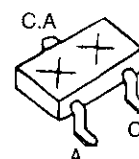

DA221

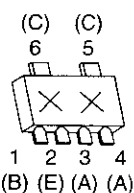

FX802
FX803

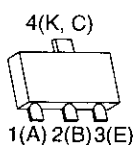

MPL1



NJM79L09

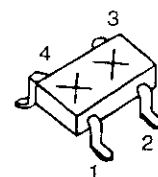

PST592KM

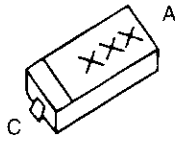

MA729
MA2S111
SFPB62
HVU350B
HVU359TR
EX0161TA
EX0210TA
EX0870CE

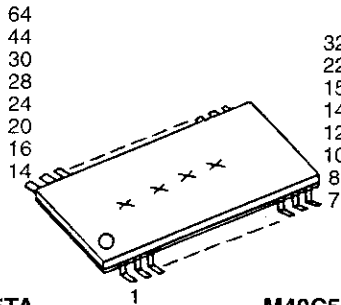

IX0265TA
IX0334TA
AK4504
BA3308FV
BA7785FS
MS548331
LB1638M
LB1950V
LB1951V
BU4053V
MM1323XJ

M40C558V
NJM2112V
TK10621M
TK10625M
T7A164S
UPD16510
MB8346BV
NJM2901V
NJM2902V
TA8517

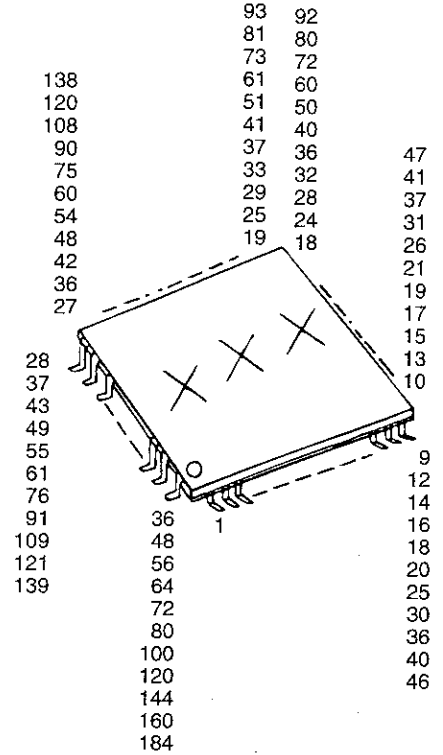

IX0264TA
IX0323TA
IX0394TA
IX0322TA
IX0325TA
IX0358TA
IX0369TA
IX0370TA

IX0400TA
IX0409TA
IX0415TA
IX0416TA
IX0419TA
BH7268KV
BH7273KV
BH7272KV

C111306F
CXA2006Q
CXS2310A
LR38511
MB88344F
LA7471M
UPC2391G

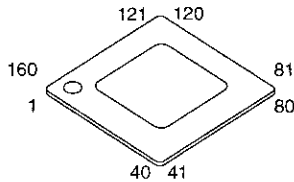

IX0357TA

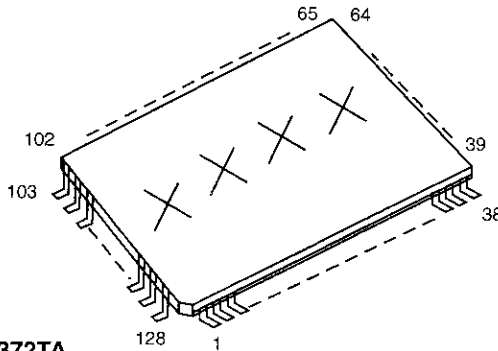

IX0372TA

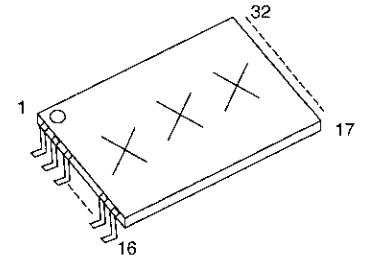

CXK5810T
IX0278TA
IX0391TA

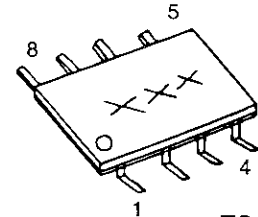

BA9701F
S8423ZF
S24C02A
TA75W558
BA7046F

TC4W66U
TC7W14U
TC7W74U
XL93L46F

13. OVERALL WIRING DIAGRAM / GESAMT-STROMLAUFPLAN 整体电路方框图

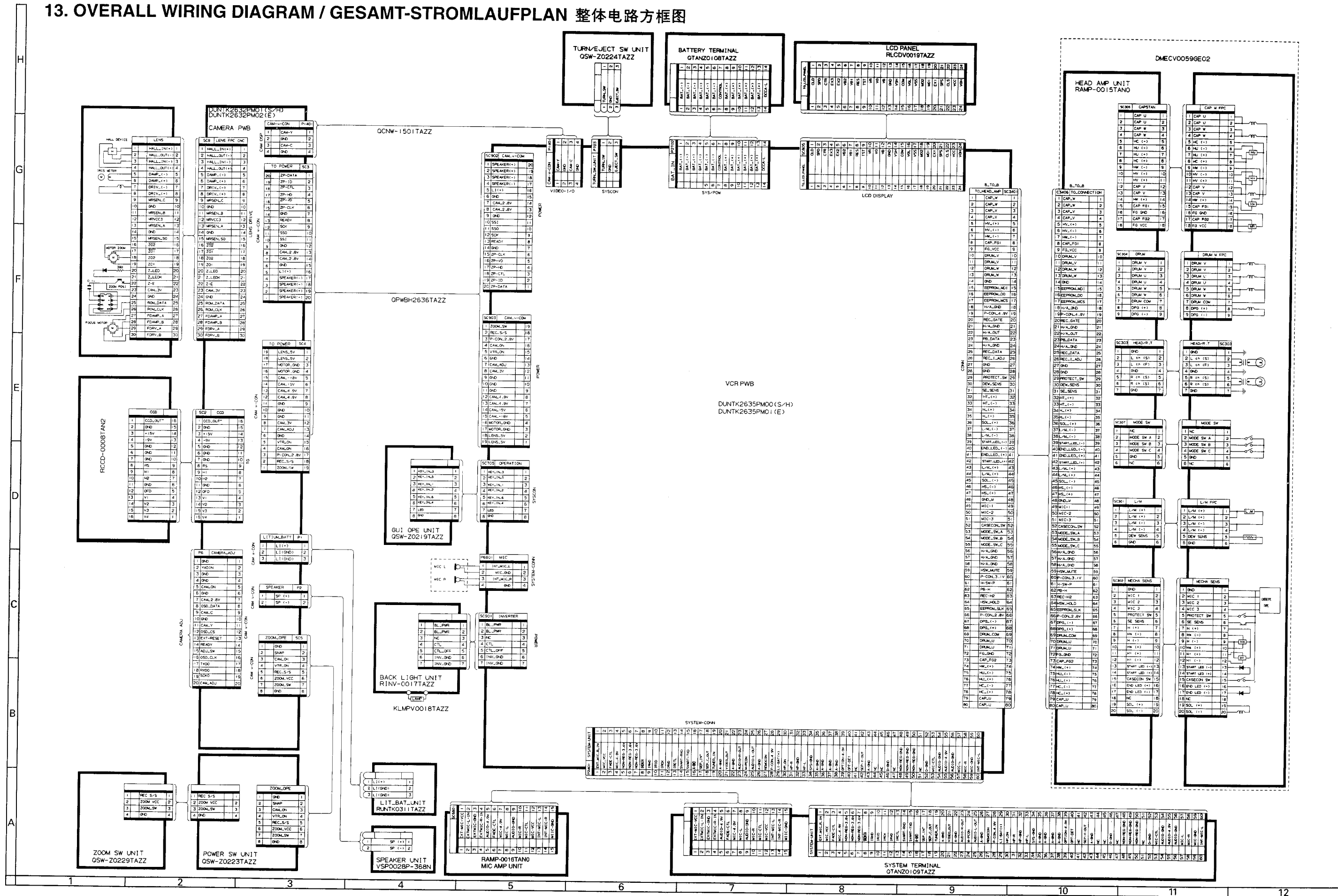

12-8. POWER SECTION BLOCK DIAGRAM / BLOCKDIAGRAMM DES STROMVERSORGUNGSTEILS 电源装置部分方框图

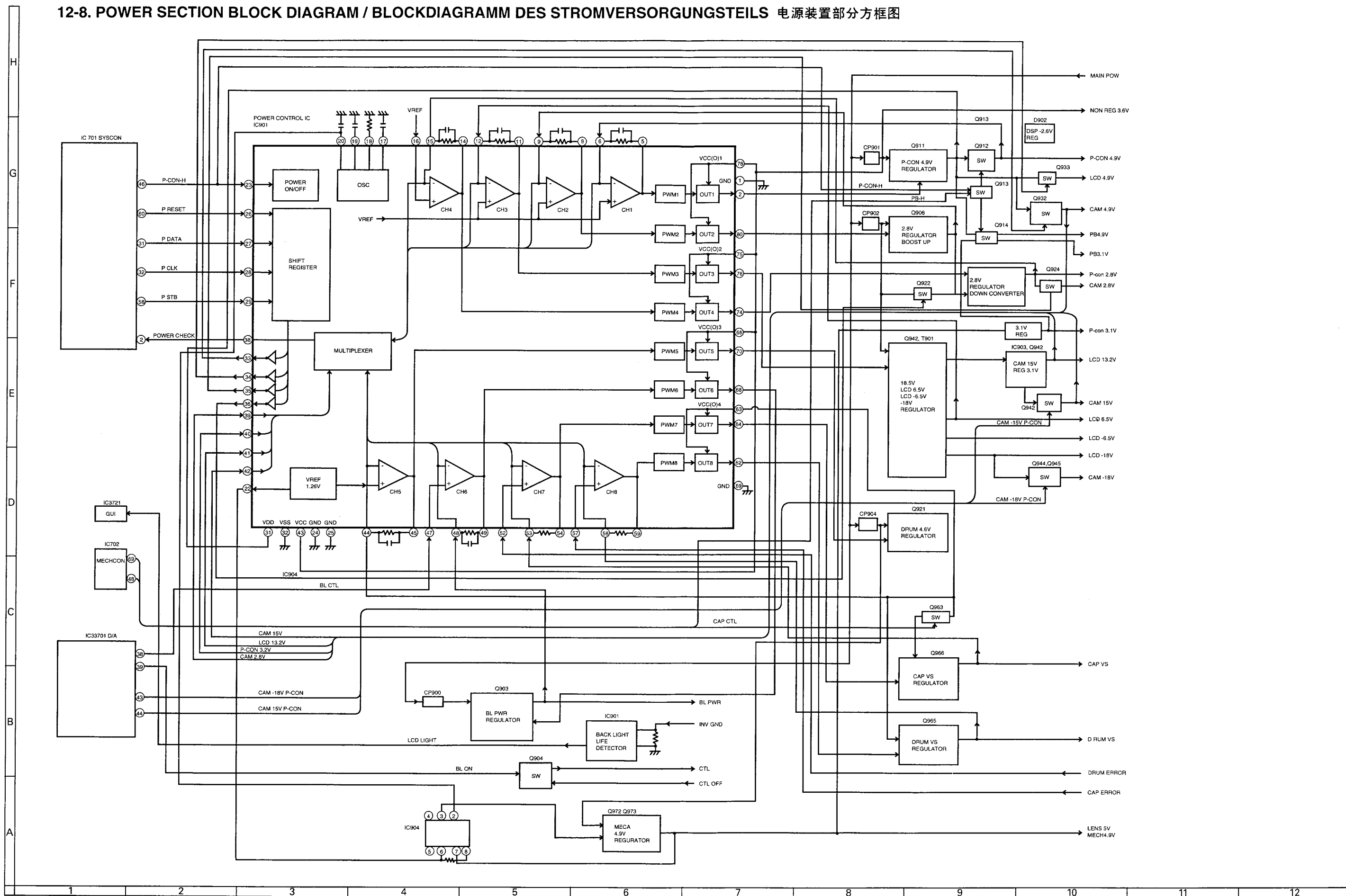

12-7. EQ/PLL BLOCK DIAGRAM / BLOCKDIAGRAMM EQ/PLL-SCHALTkreises EQ/PLL方框图

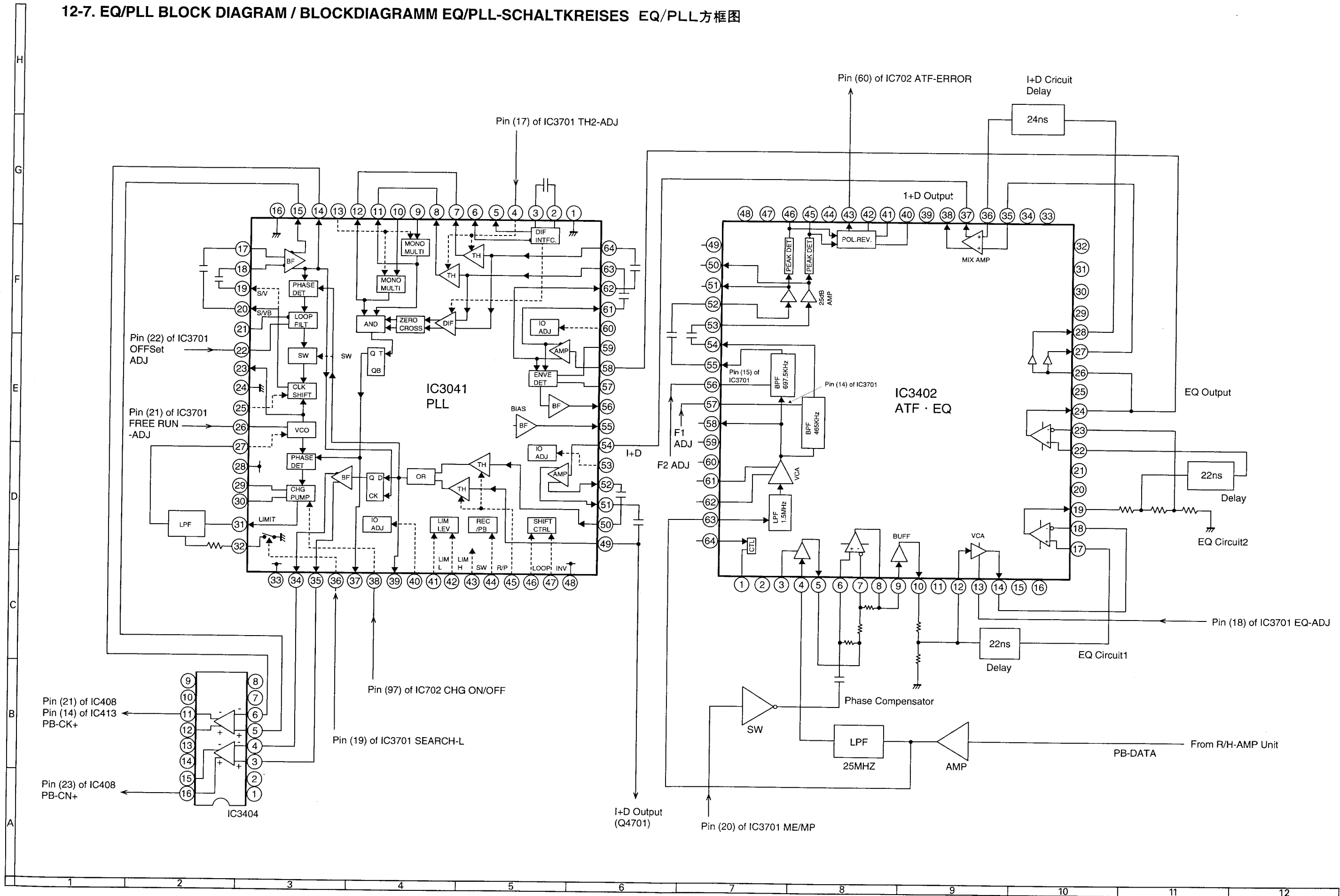

12-6. SYSTEM CONTROL/MECHANISM CONTROL BLOCK DIAGRAM / BLOCKDIAGRAMM DER SYSTEMSTEUERUNG/MECHANIKSTEUERUNG 系统控制/机构控制器电路方框图

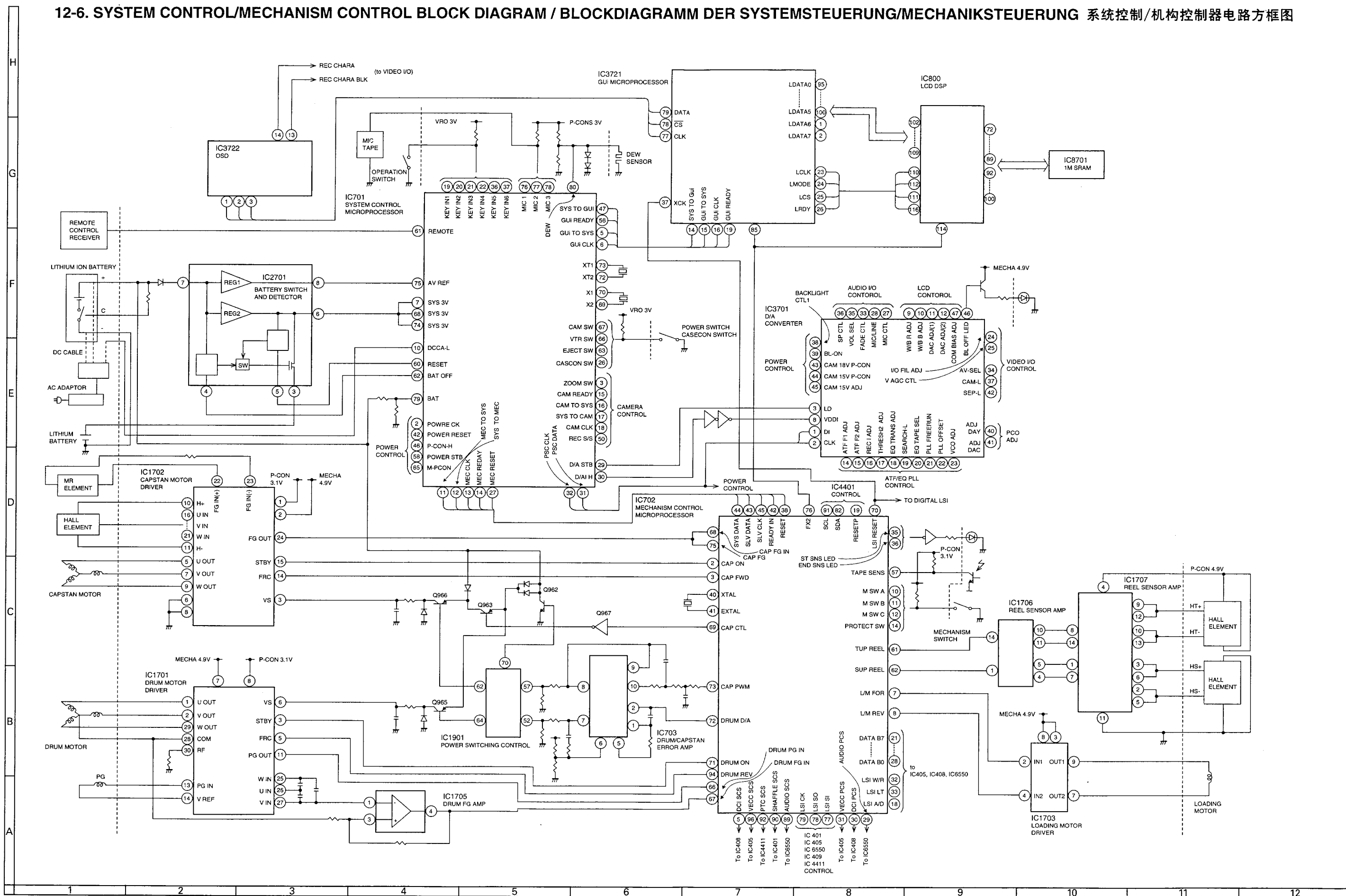

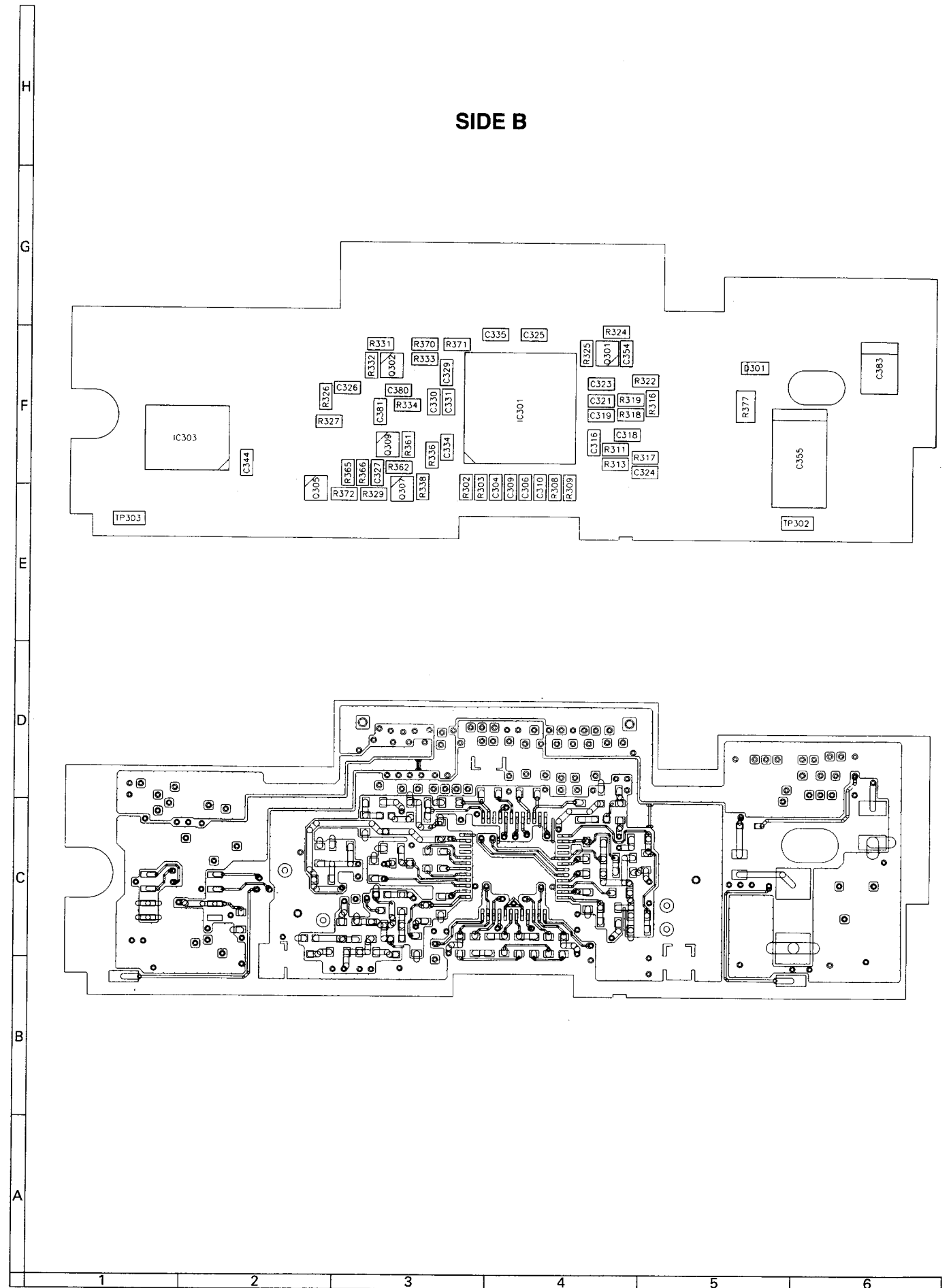

HEAD AMP. PWB UNIT / PWB-EINHEIT DES VORVERSTÄRKERS
摄影机放大器用印刷电路板组件

SIDE A

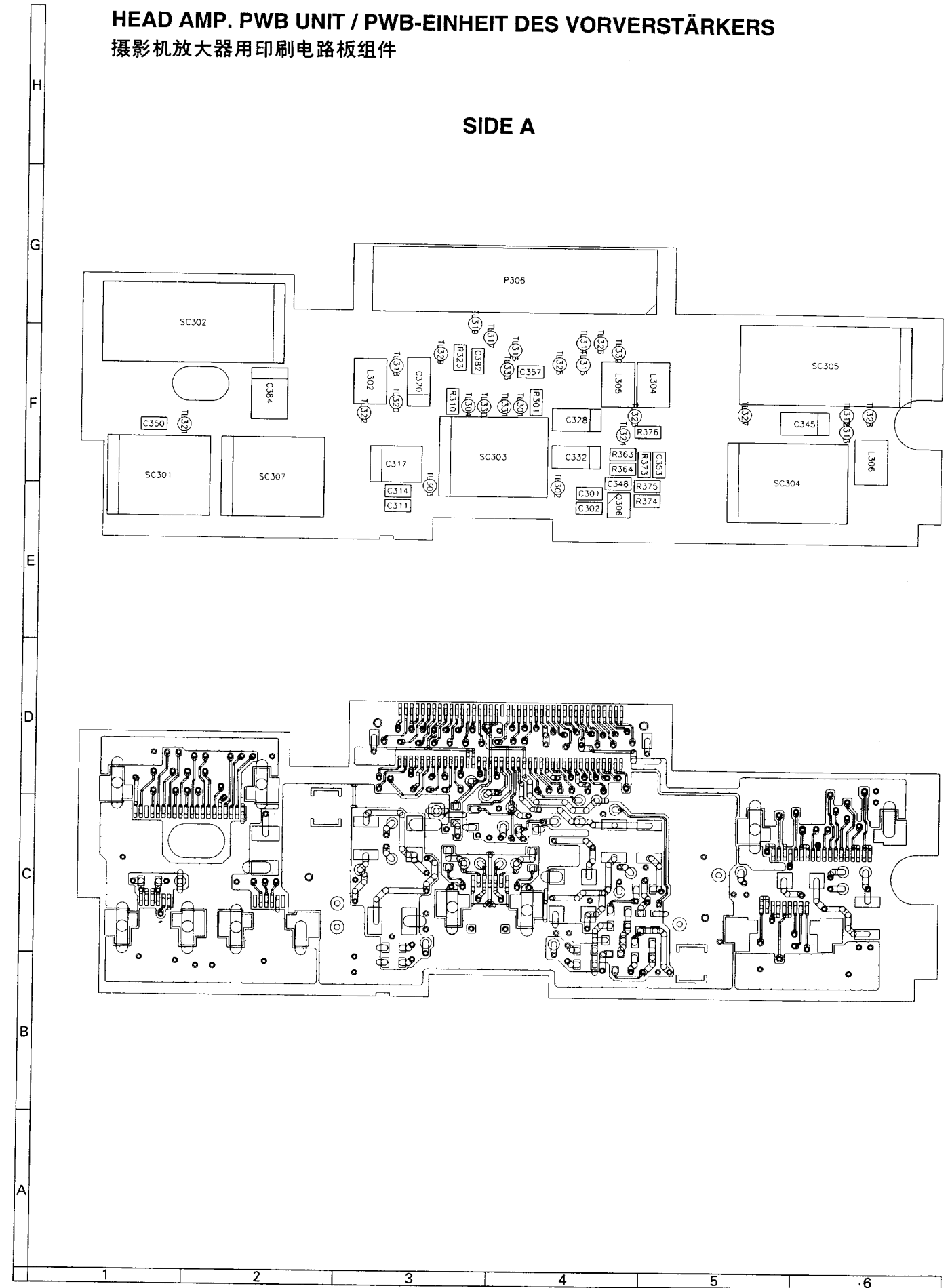

CCD PWB UNIT / PWB-EINHEIT DES CCD CCD用印刷电路板组件

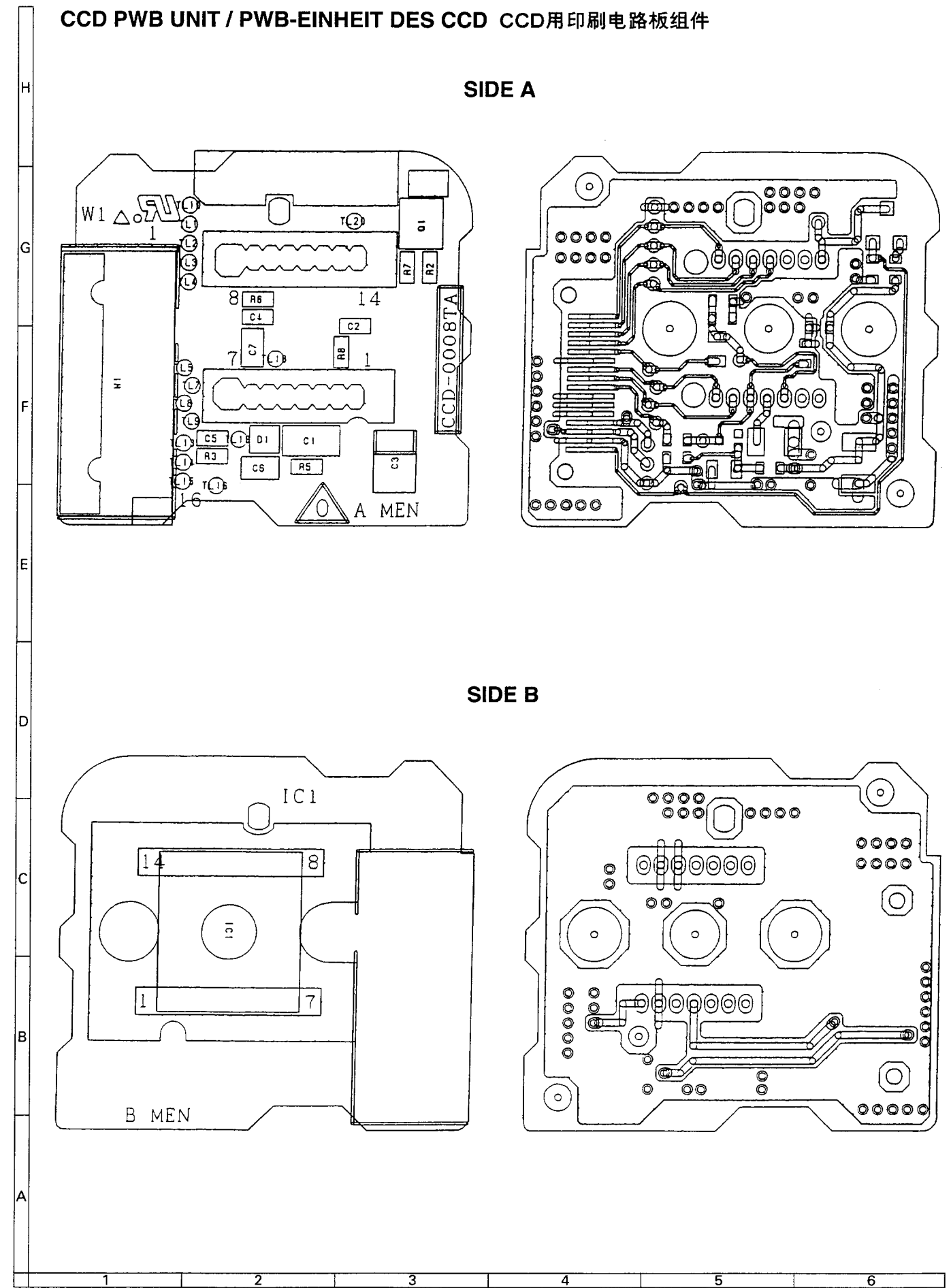

VCR PWB UNIT (SIDE A) / PWB-EINHEIT DES VCR (SEITE A) 录像机用印刷电路板组件(A面)

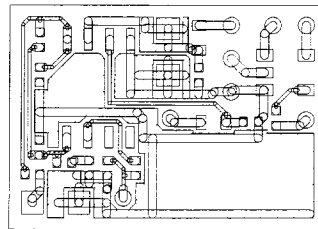

OSD HD GENERATER PWB UNIT /
PWB-EINHEIT DES OSD HD-GENERATORS
OSD HD信号发生器用印刷电路板组件

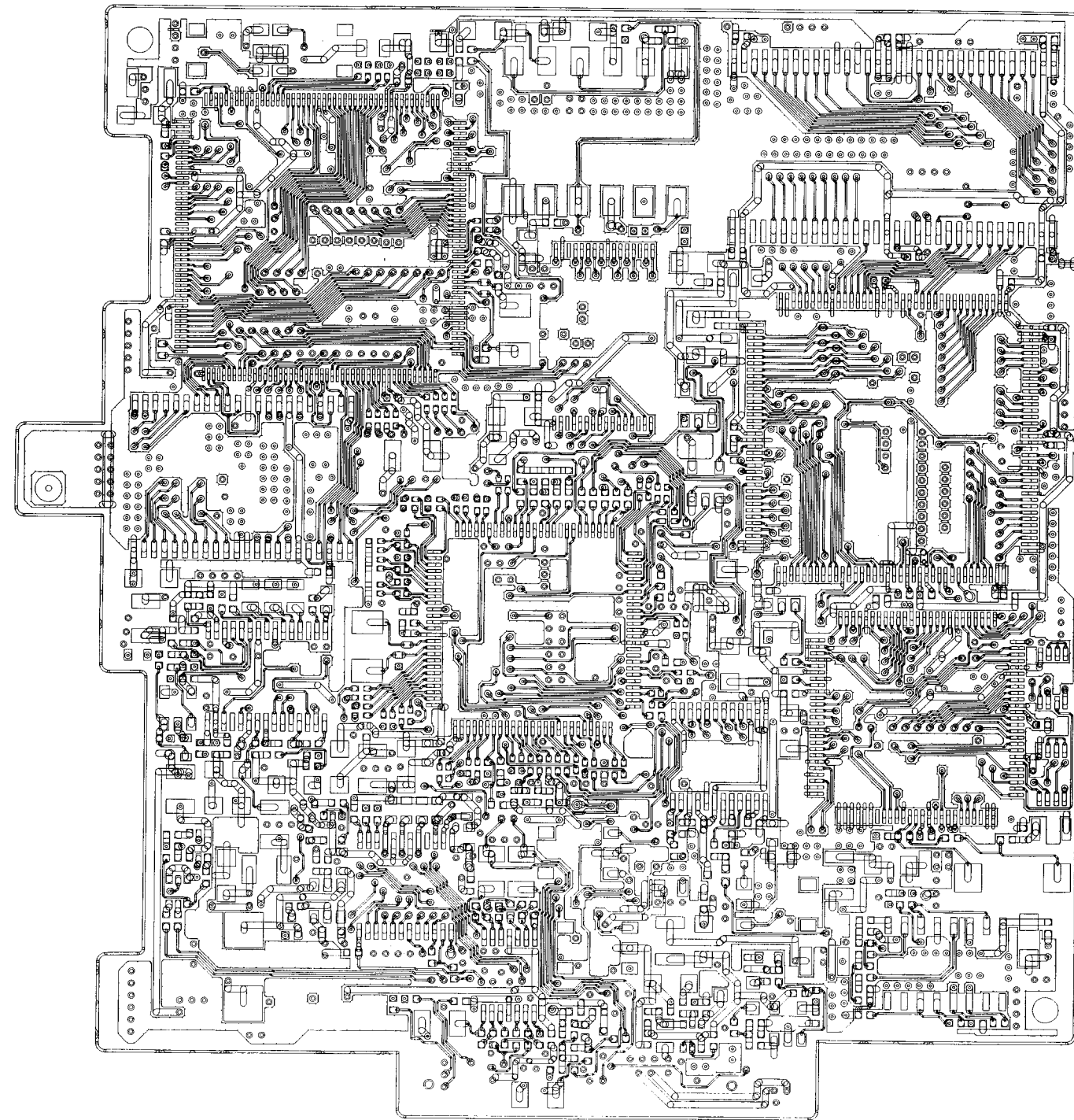
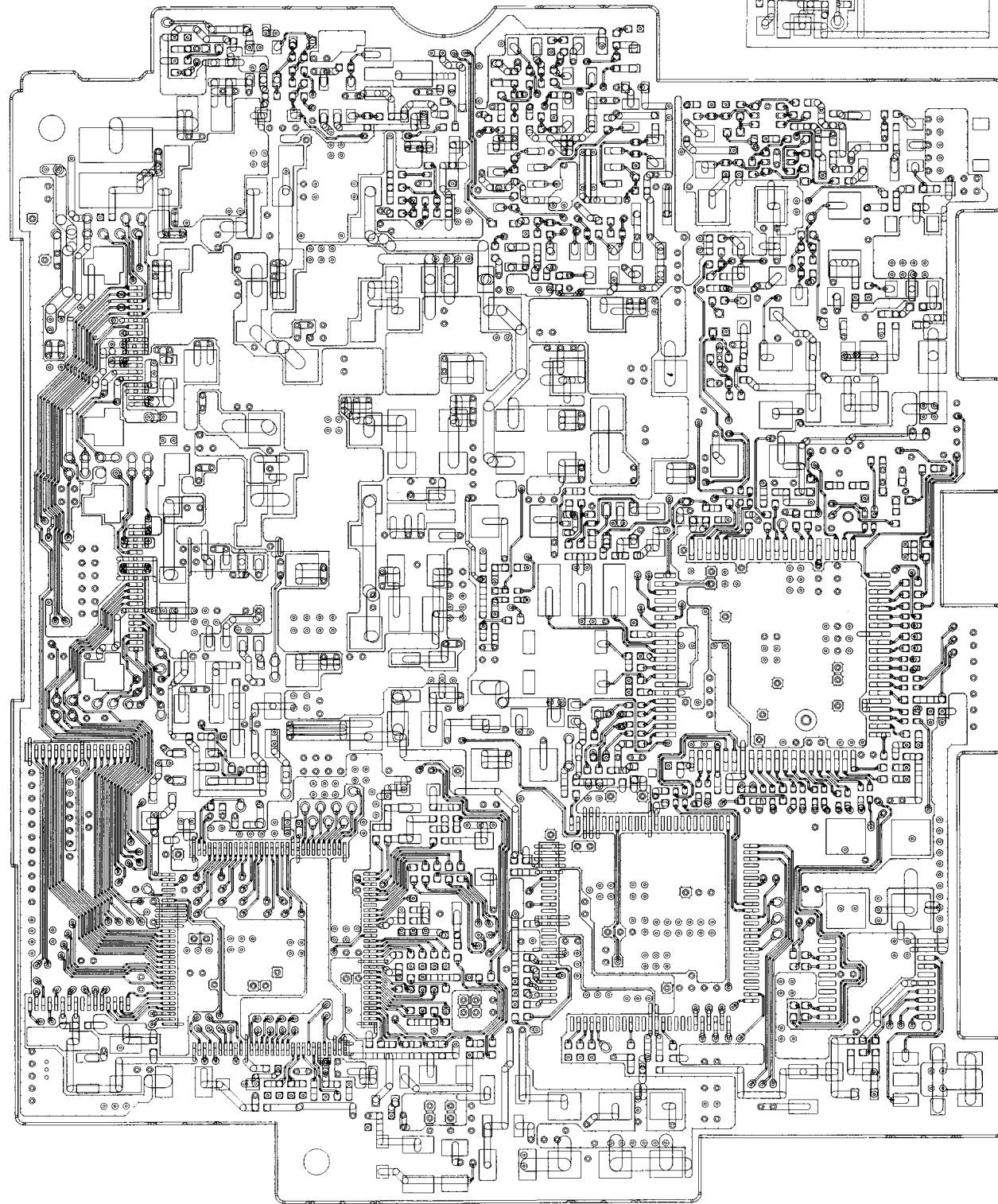

VCR-2

VCR-1

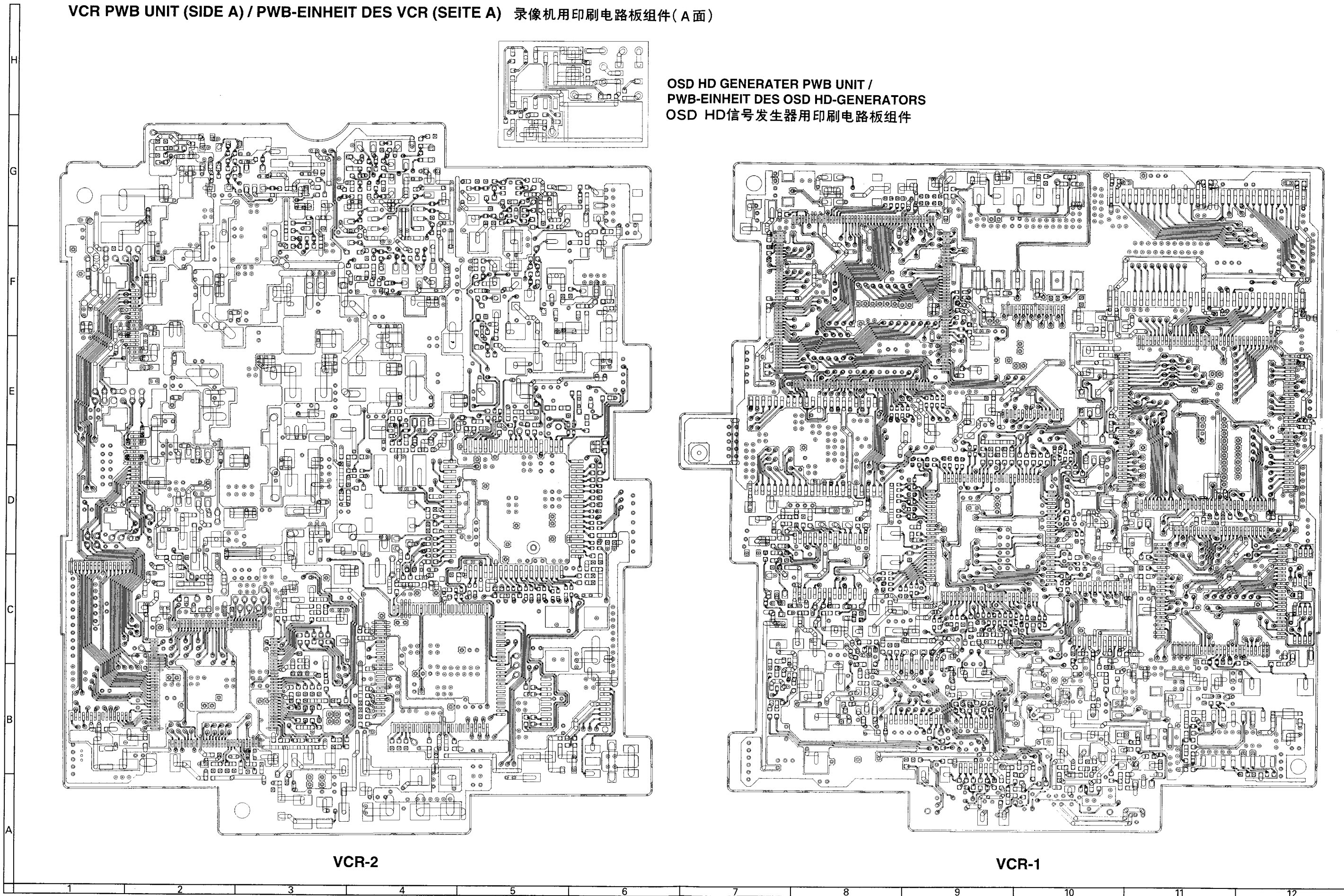

VCR PWB UNIT (SIDE B) / PWB-EINHEIT DES VCR (SEITE B) 录像机用印刷电路板组件(B面)

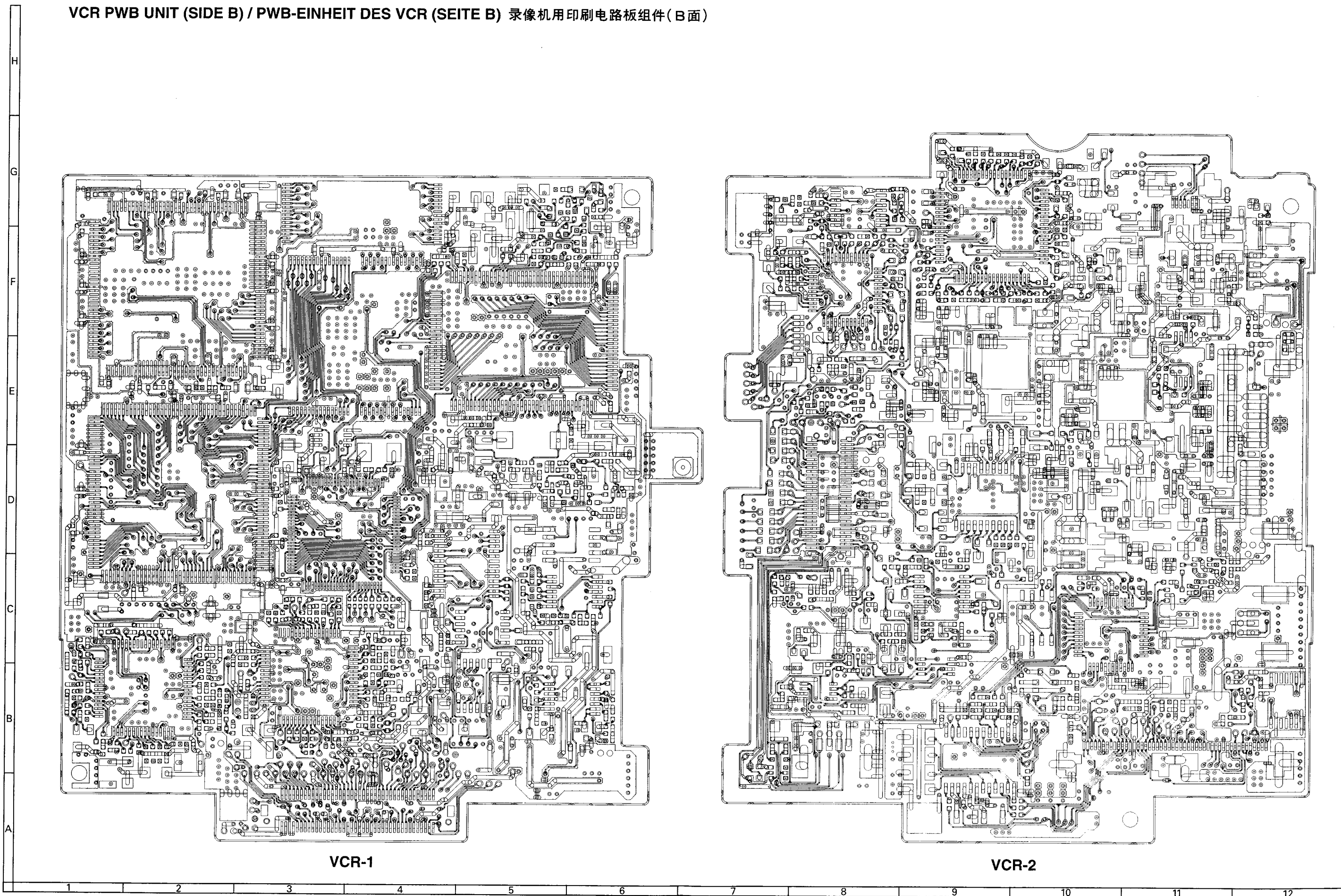

VCR-1

VCR-2

16-2. ADC CIRCUIT SCHEMATIC DIAGRAM / STROMLAUFPLAN DES ADC-SCHALTKREISES ADC 电路原理图

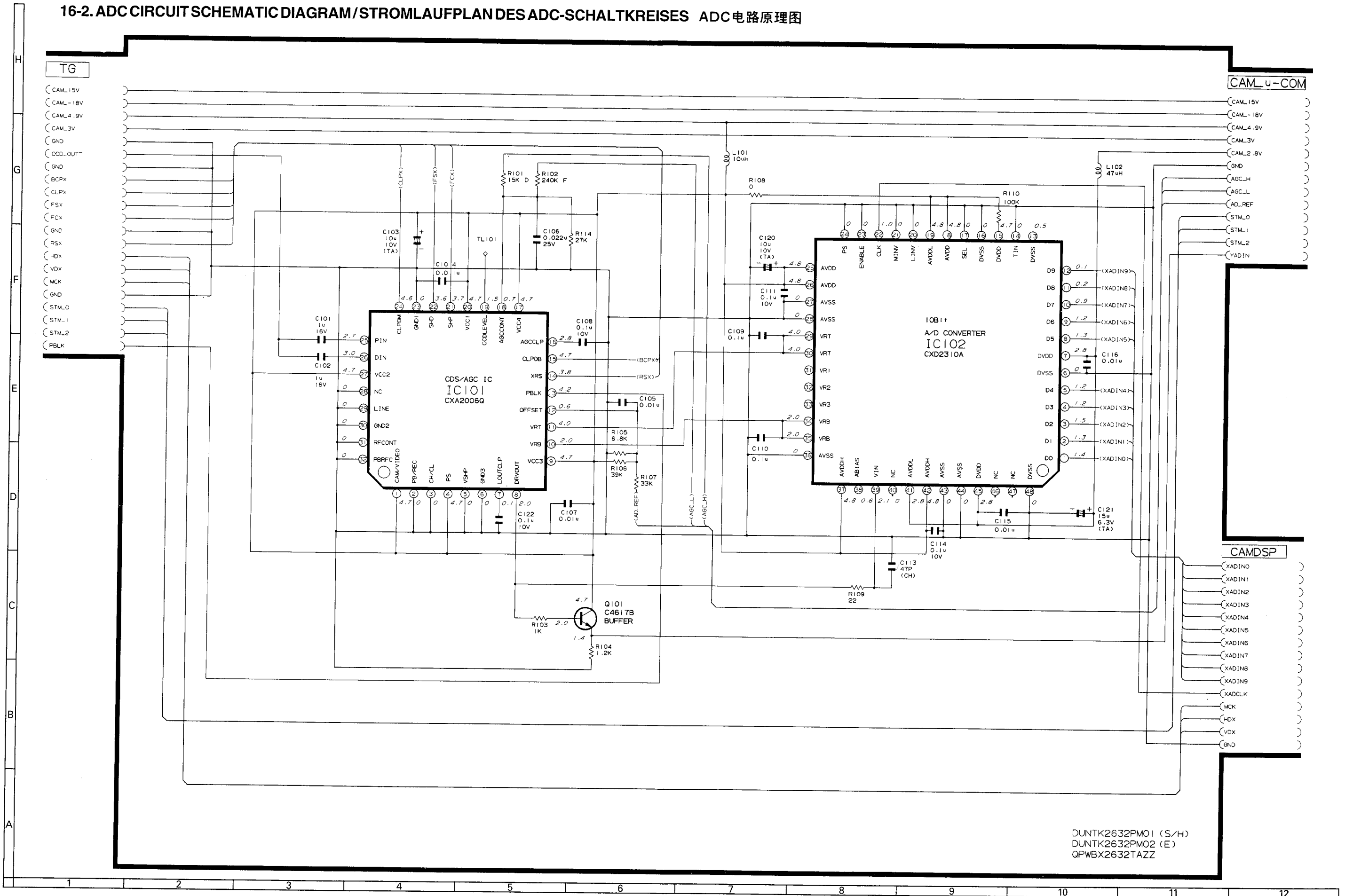

DUNTK2632PM01 (S/H)
DUNTK2632PM02 (E)
QPWBX2632TAZZ

16-4. LENS DRIVE CIRCUIT SCHEMATIC DIAGRAM / STROMLAUFPLAN DES OBJEKTIVANTRIEB-SCHALTKREISES 镜头激励电路原理图

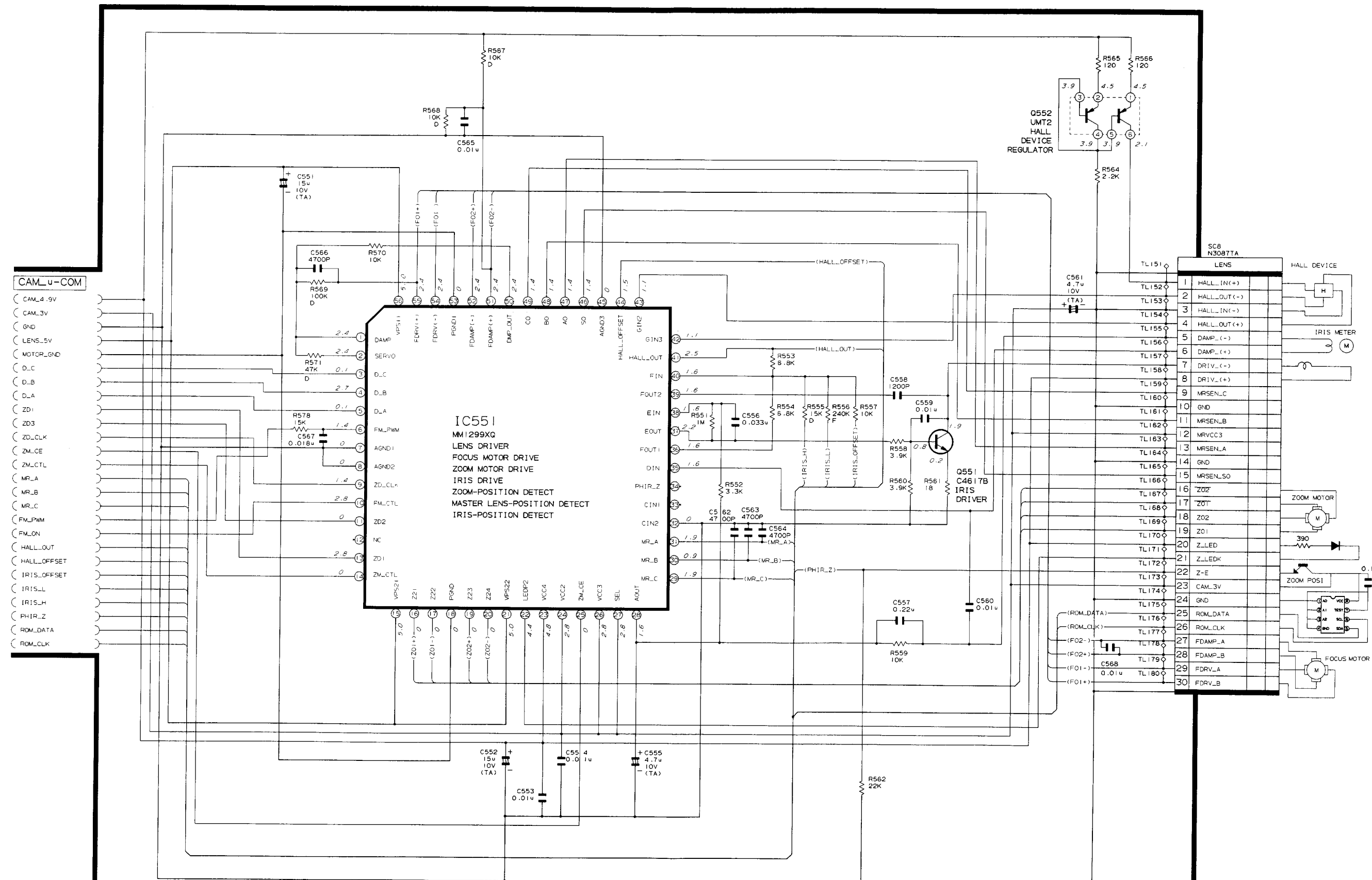

DUNTK2632PM01 (S/H)
DUNTK2632PM02 (E)
QPWBX2632TAZZ

16-3. CAMERA DISPLAY CIRCUIT SCHEMATIC DIAGRAM / STROMLAUFPLAN DES KAMERADISPLAY-SCHALTKREISES 摄影机显示屏电路原理图

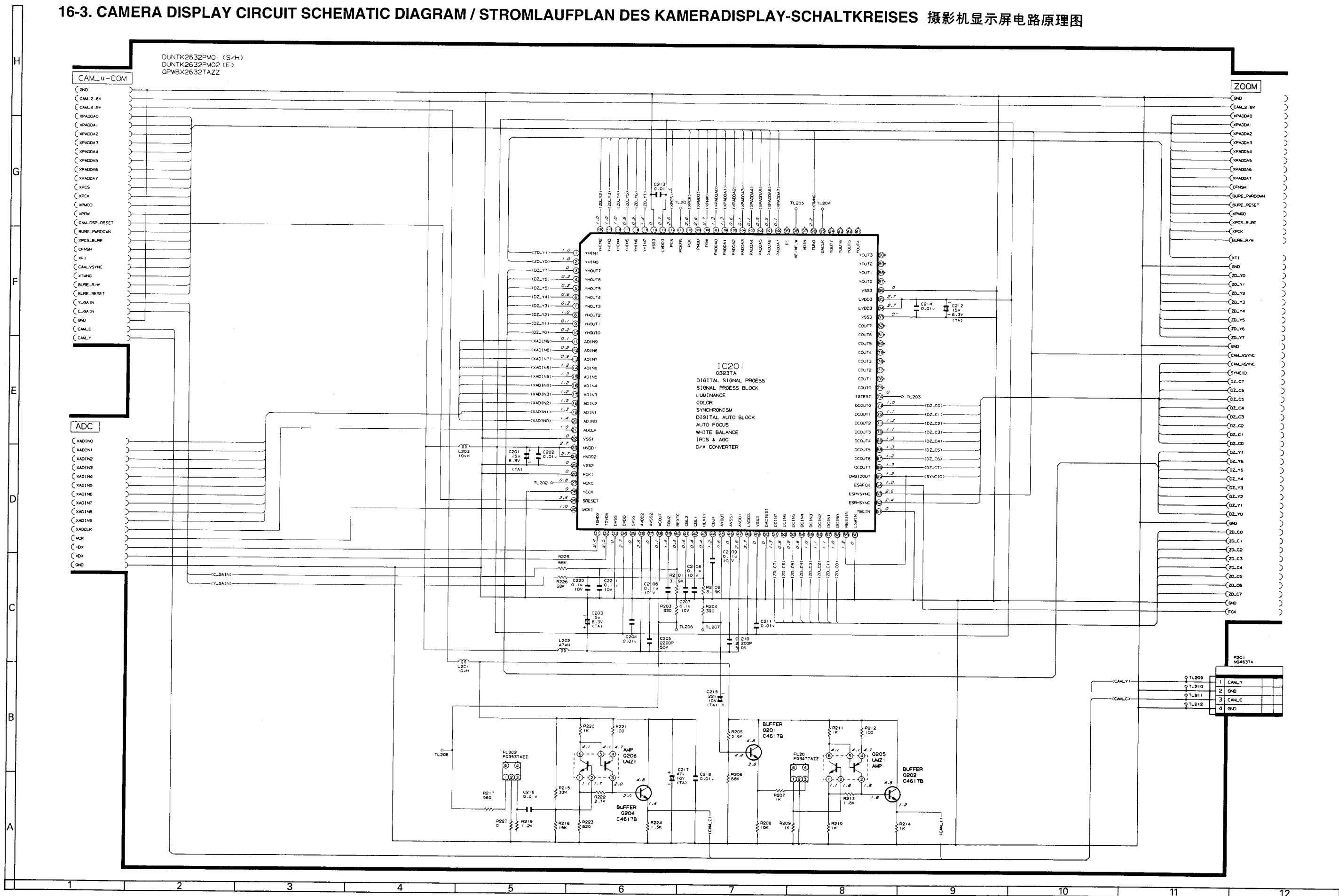

16-6. CAMERA CONTROL MICROPROCESSOR CIRCUIT SCHEMATIC DIAGRAM (VL-DC1H/S) /
STROMLAUFPLAN DES KAMERASTEUERUNG-MIKROPROZESSORSCHALTKREISES (VL-DC1H/S) 摄影控制器微电脑处理机电路原理图 (型号VL-DC1H/S)

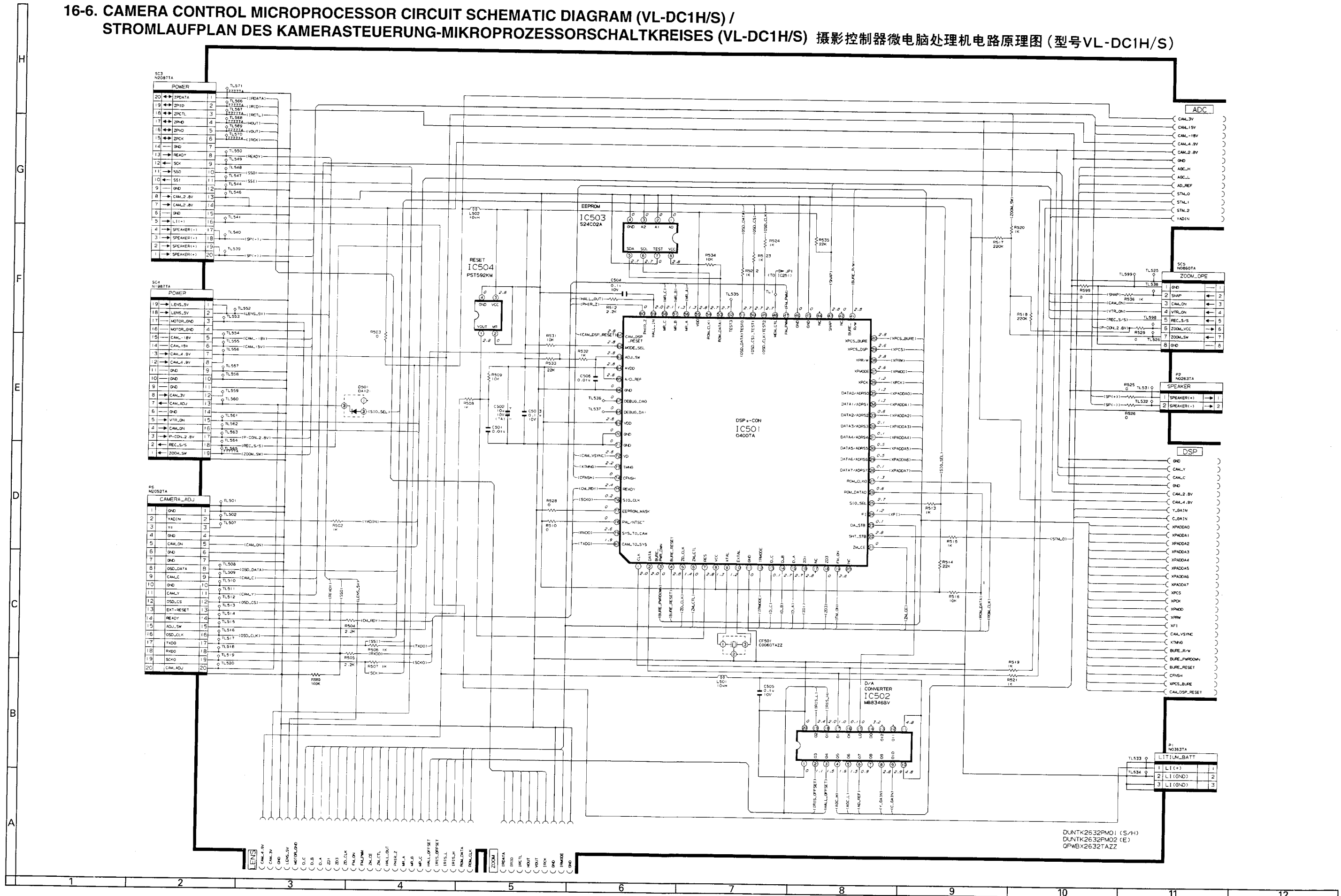

16-5. CAMERA CONTROL MICROPROCESSOR CIRCUIT SCHEMATIC DIAGRAM (VL-DC1E) /
STROMLAUFPLAN DES KAMERASTEUERUNG-MIKROPROZESSORSCHALTKREISES (VL-DC1E) 摄影控制器微电脑处理机电路原理图 (型号VL-DC1E)

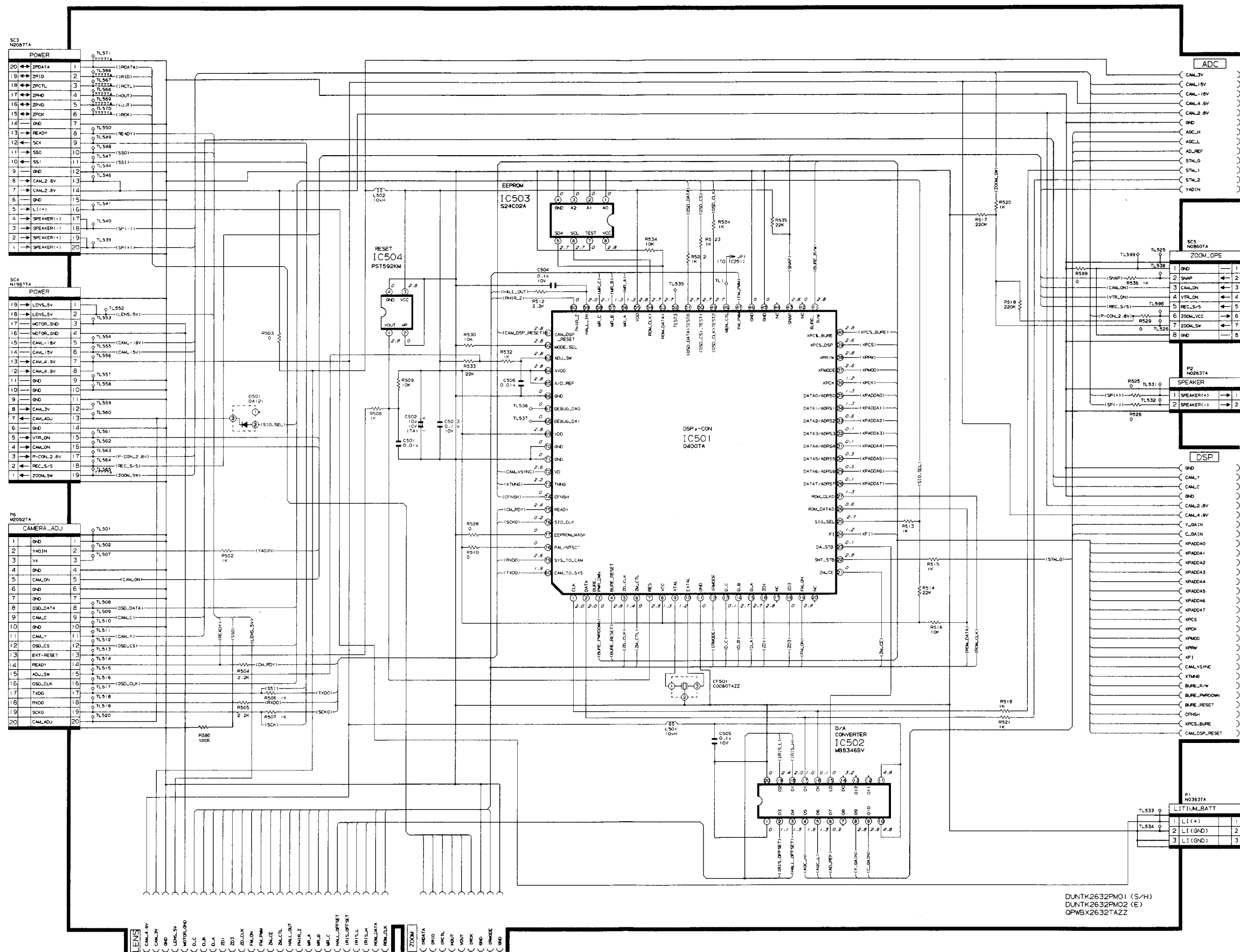

DUNTK2632PM01 (S/H)
DUNTK2632PM02 (E)
OPWSX2632TAZZ

17. VCR-1 CIRCUIT SCHEMATIC DIAGRAM / STROMLAUFPLAN DES VCR-1-SCHALTKREISES 录像机-1电路原理图
 17-1. ATF EQ/PLL CIRCUIT SCHEMATIC DIAGRAM / STROMLAUFPLAN DES ATF EQ/PLL-SCHALTKREISES ATF EQ/PLL 电路原理图

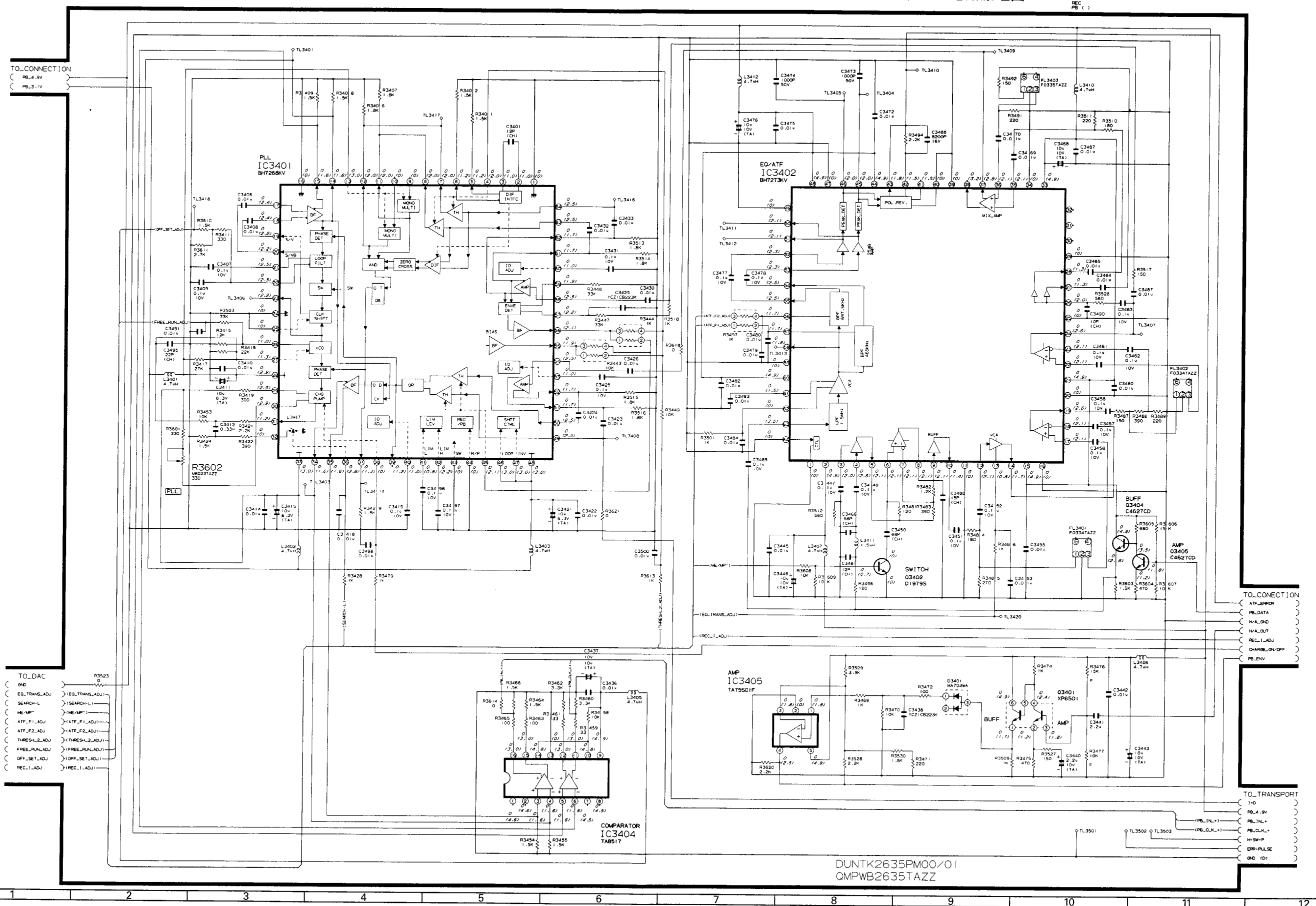

16-7. ZOOM CIRCUIT SCHEMATIC DIAGRAM / STROMLAUFPLAN DES ZOOM-SCHALTKREISES 变焦电路原理图

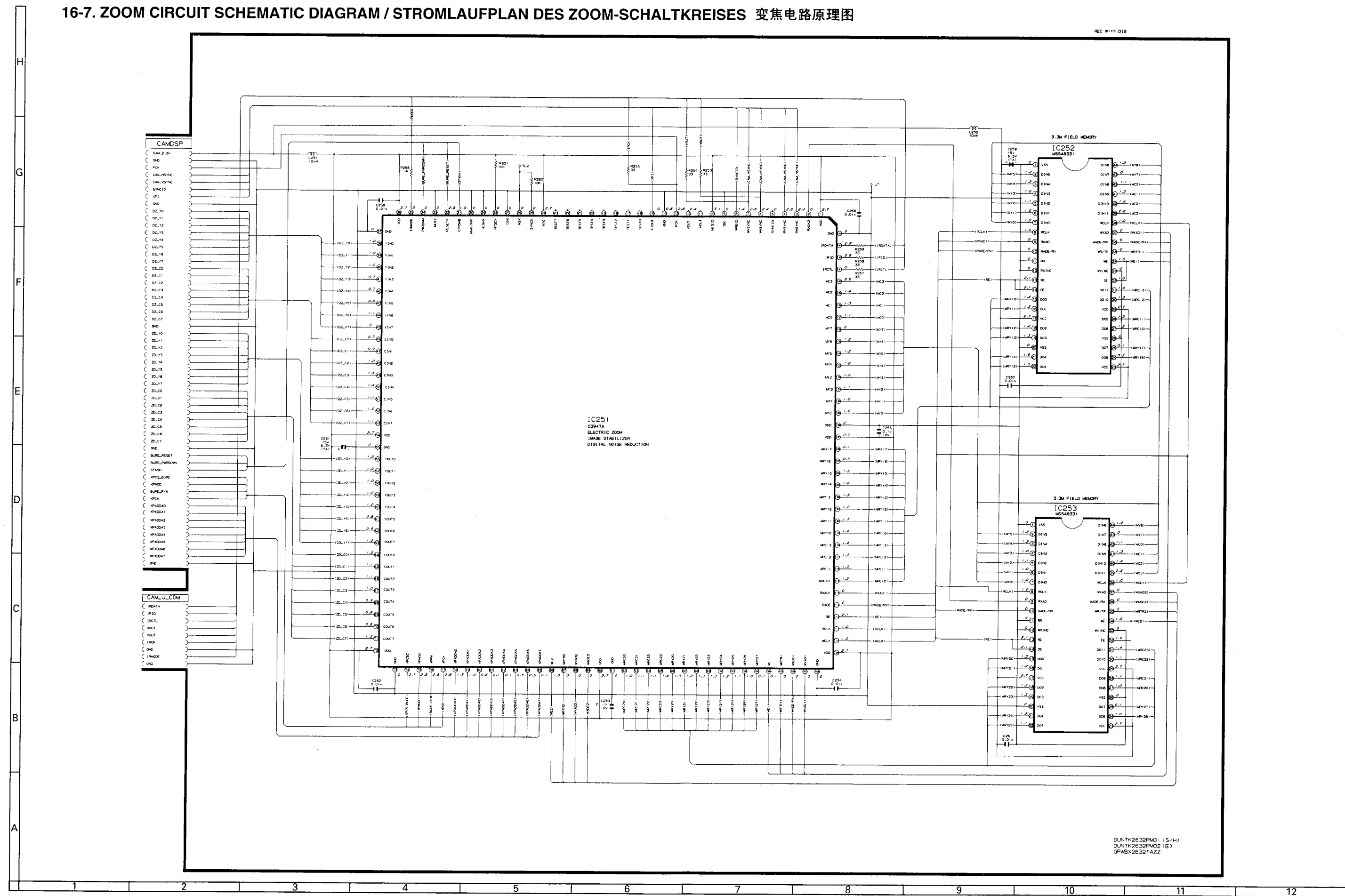

17-3. MECHANICAL CONVERTER CIRCUIT SCHEMATIC DIAGRAM / STROMLAUFPLAN DES MECHANISCHEN WANDLER-SCHALTKREISES 机构变频器电路原理图

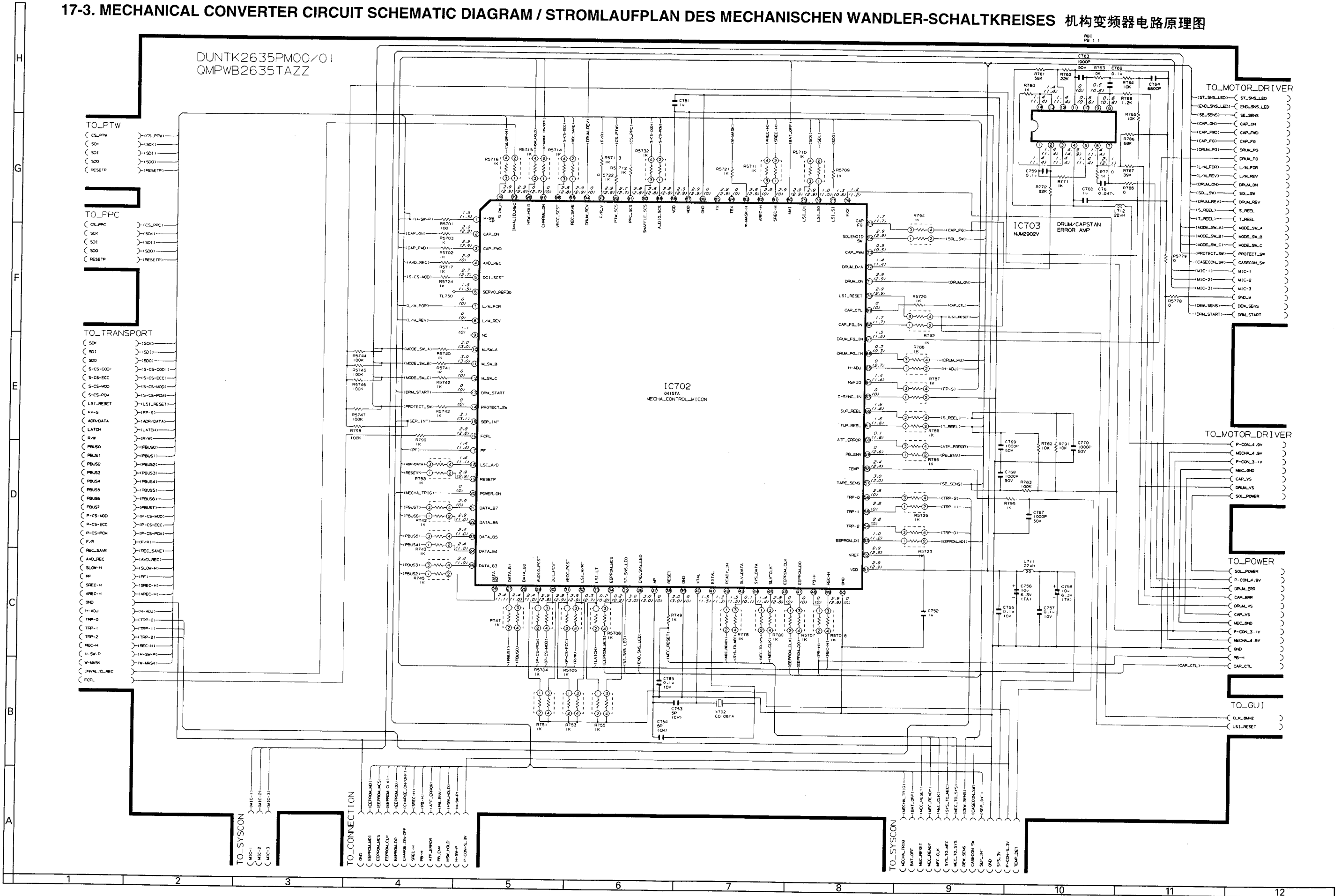

17-2. CONNECTION (B-B) CIRCUIT SCHEMATIC DIAGRAM / STROMLAUFPLAN DES ANSCHLUSS-SCHALTkreISES (B-B) 连接(B-B)电路原理图

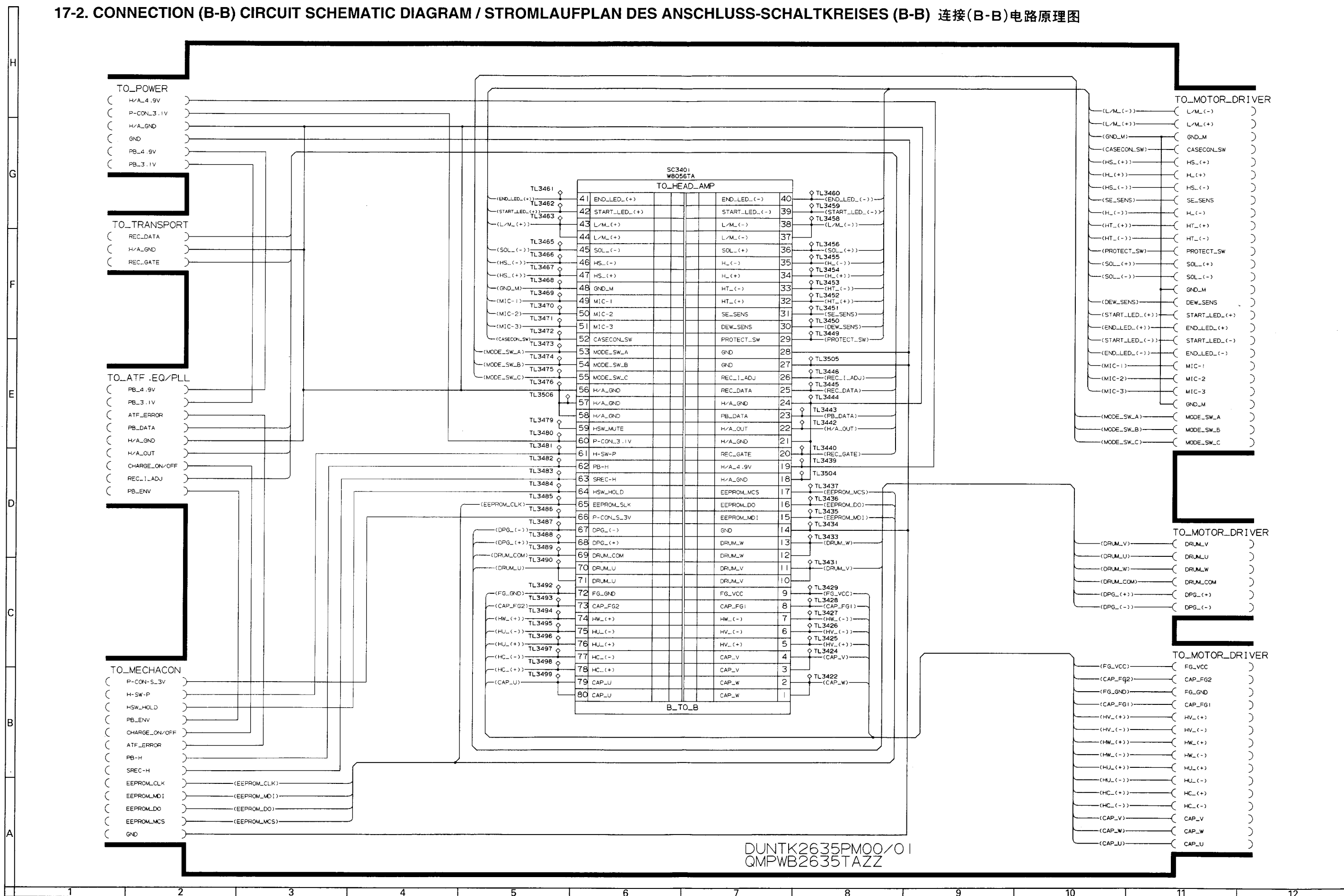

DUNTK2635PM00/O1
QMPWB2635TAZZ

17-5. PC/IO CIRCUIT SCHEMATIC DIAGRAM / STROMLAUFPLAN DES PC/IO-SCHALTKREISES PC/IO电路原理图

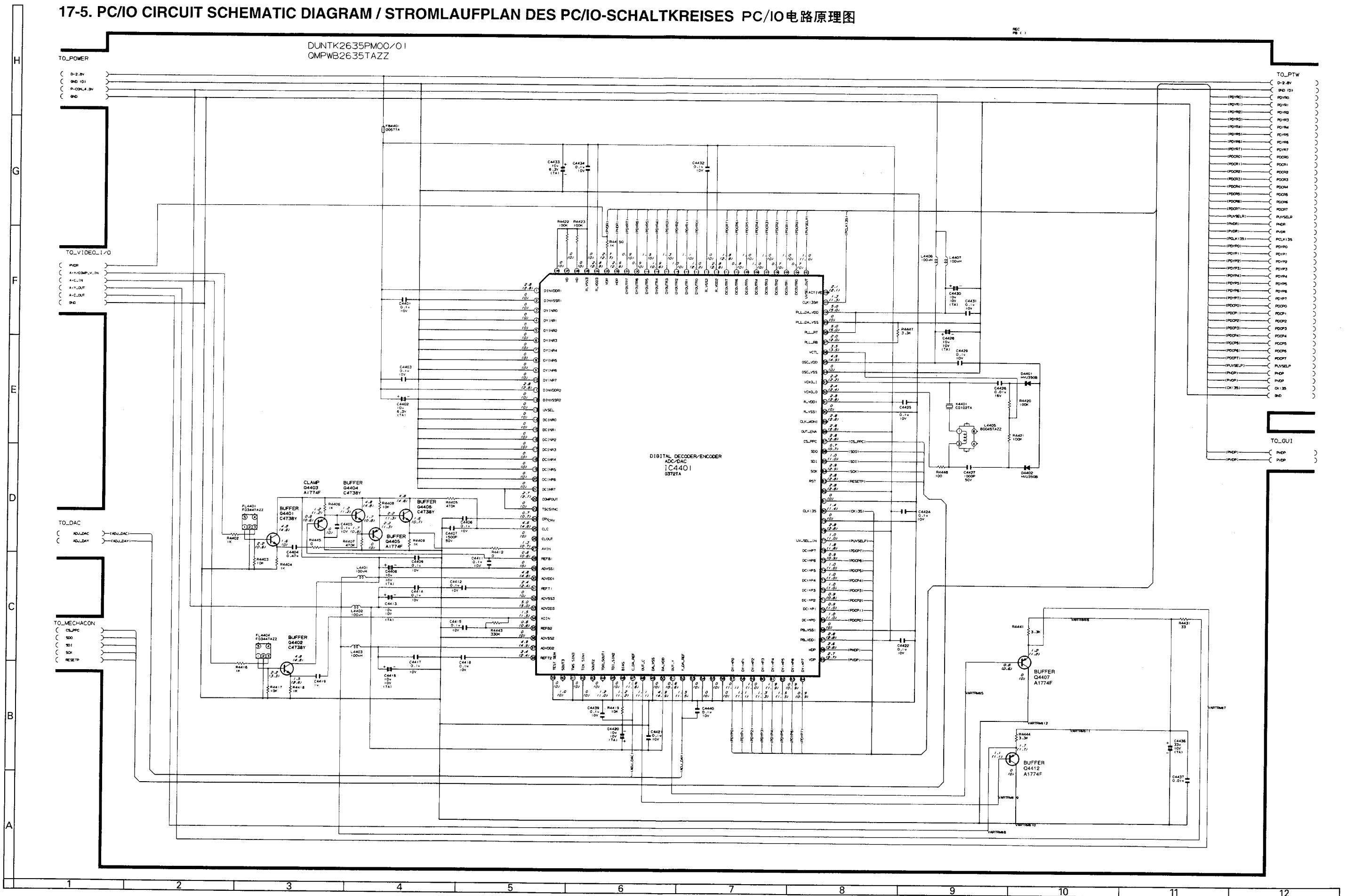

17-4. MOTOR DRIVE CIRCUIT SCHEMATIC DIAGRAMNEW / STROMLAUFPLAN DES MOTORANTRIEB-SCHALTKREISES 马达激励电路原理图

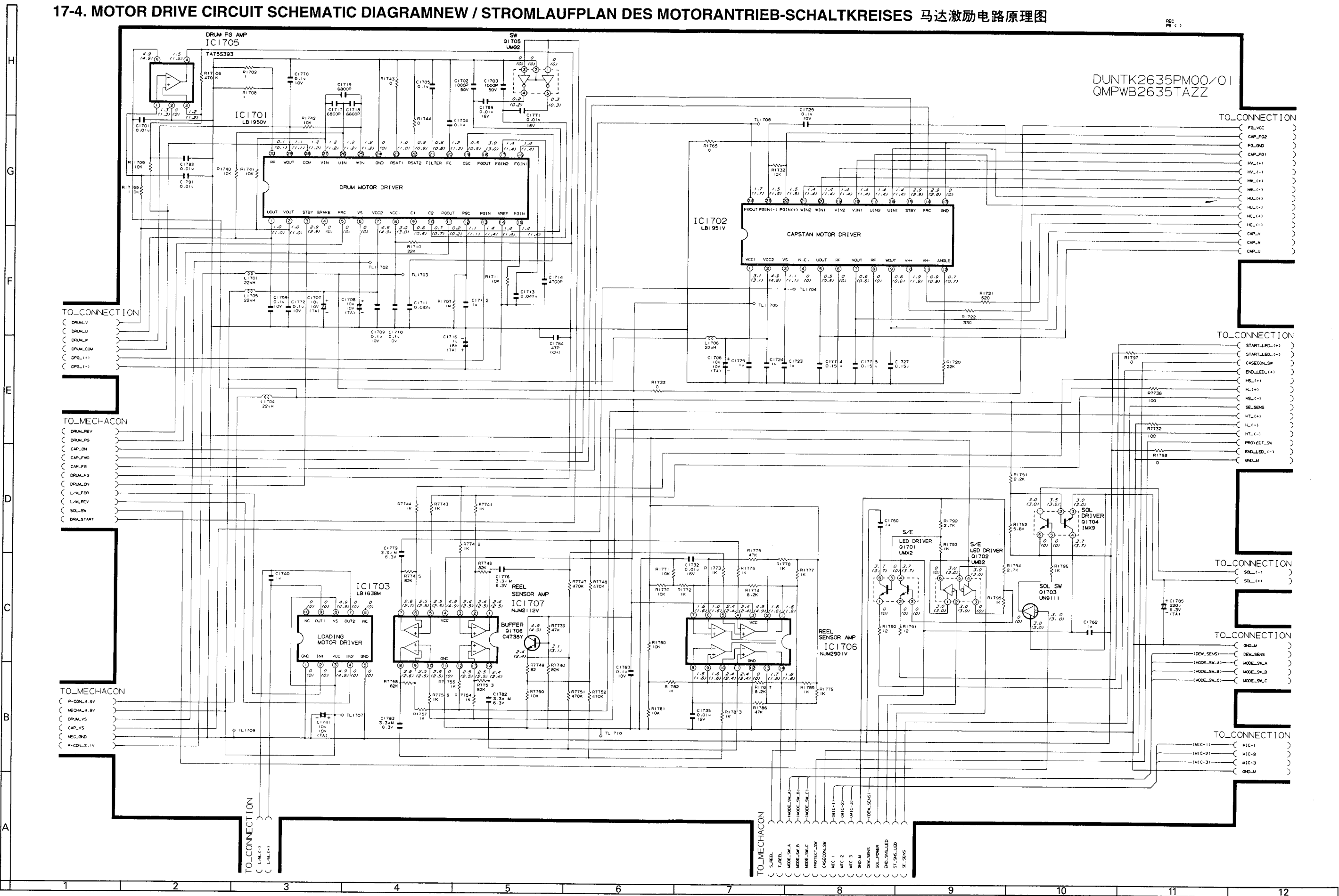

DUNTK2635PM00/O1
QMPWB2635TAZZ

17-7. CODEC CIRCUIT SCHEMATIC DIAGRAM / STROMLAUFPLAN DES CODEC-SCHALTKREISES 编码译码器电路原理图

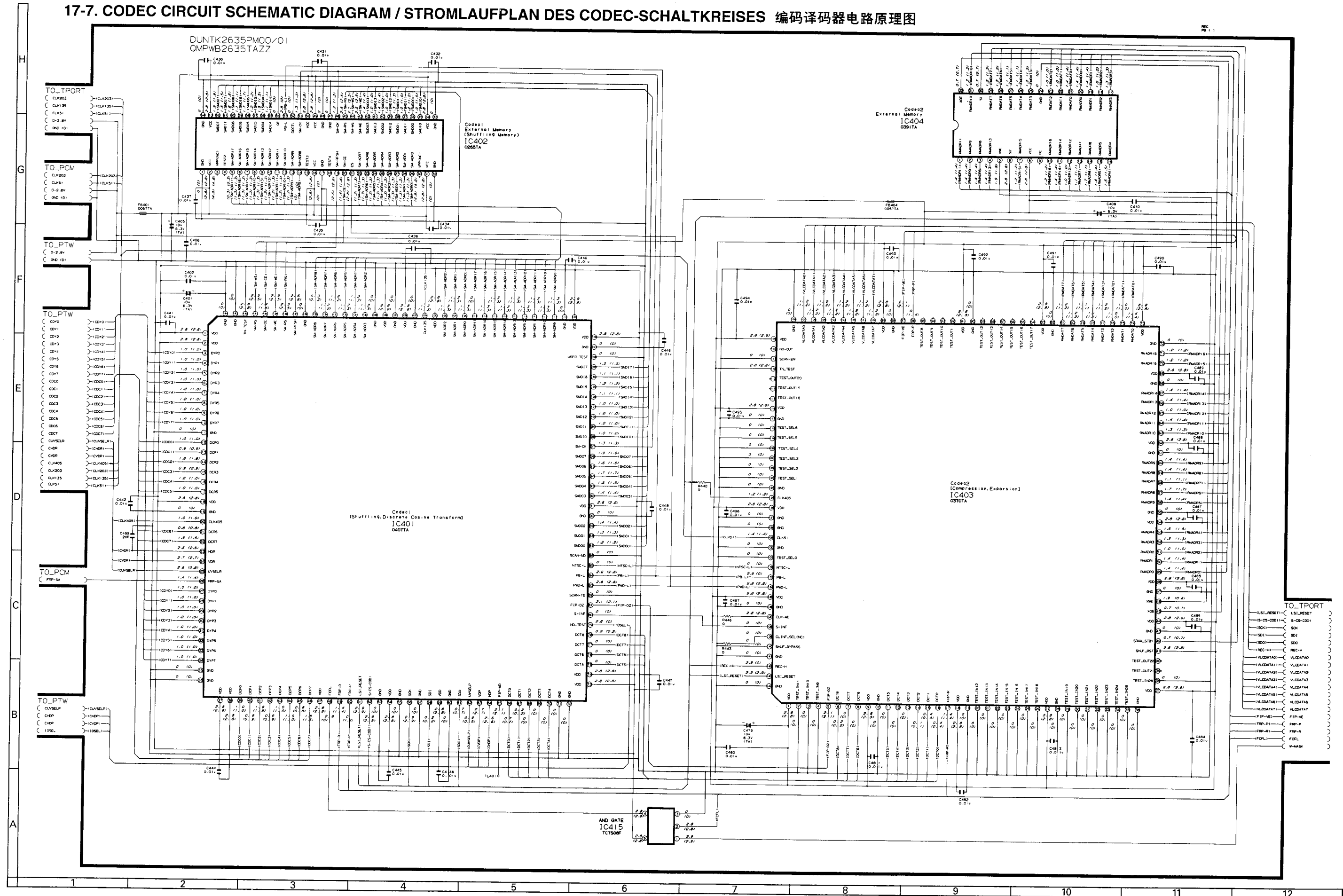

17-6. PTS CIRCUIT SCHEMATIC DIAGRAM / STROMLAUFPLAN DES PTS-SCHALTKREISES PTS电路原理图

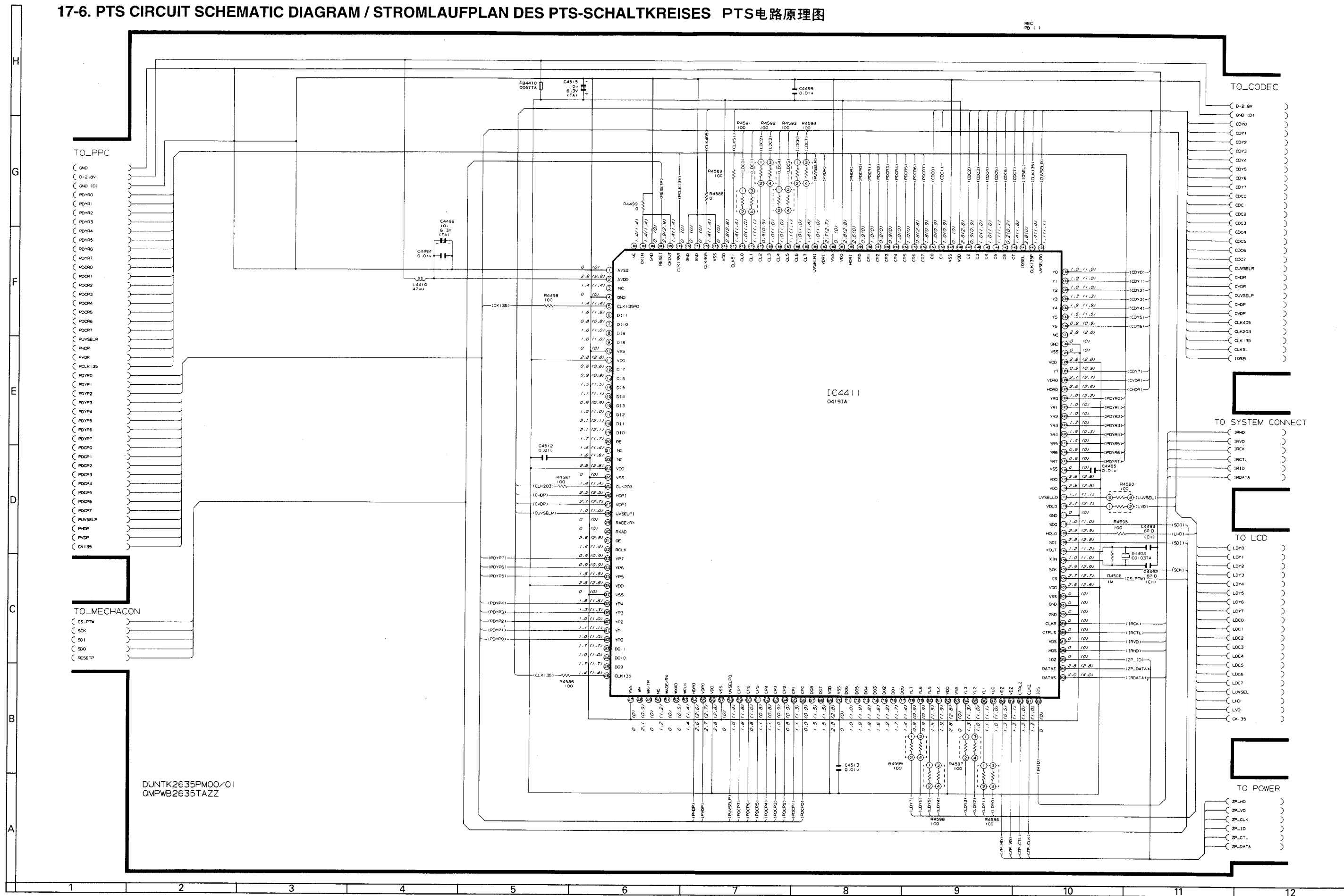

17-9. PCM CIRCUIT SCHEMATIC DIAGRAM / STROMLAUFPLAN DES PCM-SCHALTKREISES PCM电路原理图

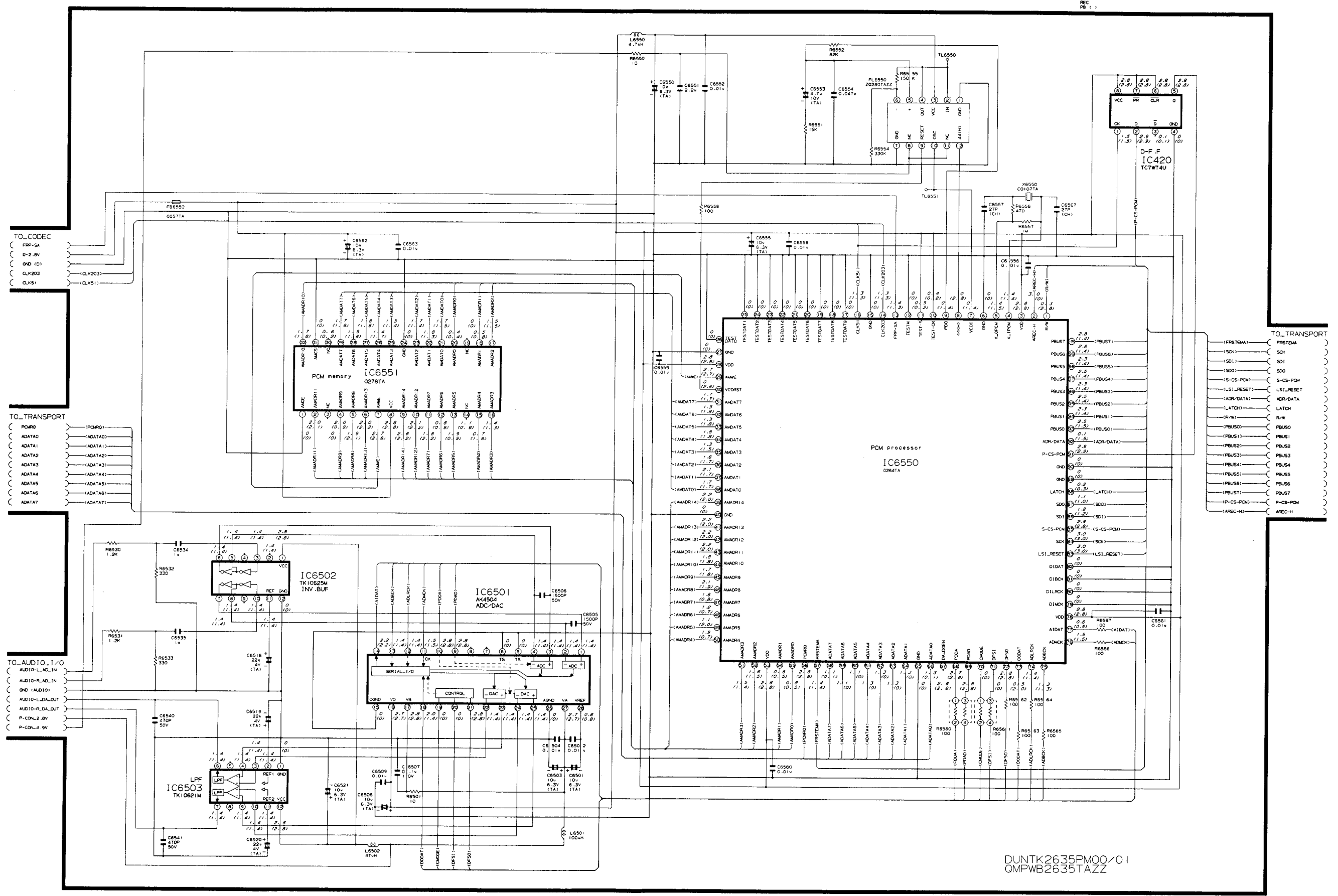

DUNTK2635PM00/01
QMPWB2635TAZZ

17-8. TRANSPORT CIRCUIT SCHEMATIC DIAGRAM / STROMLAUFPLAN DES TRANSPORT-SCHALTKREISES 传送电路原理图

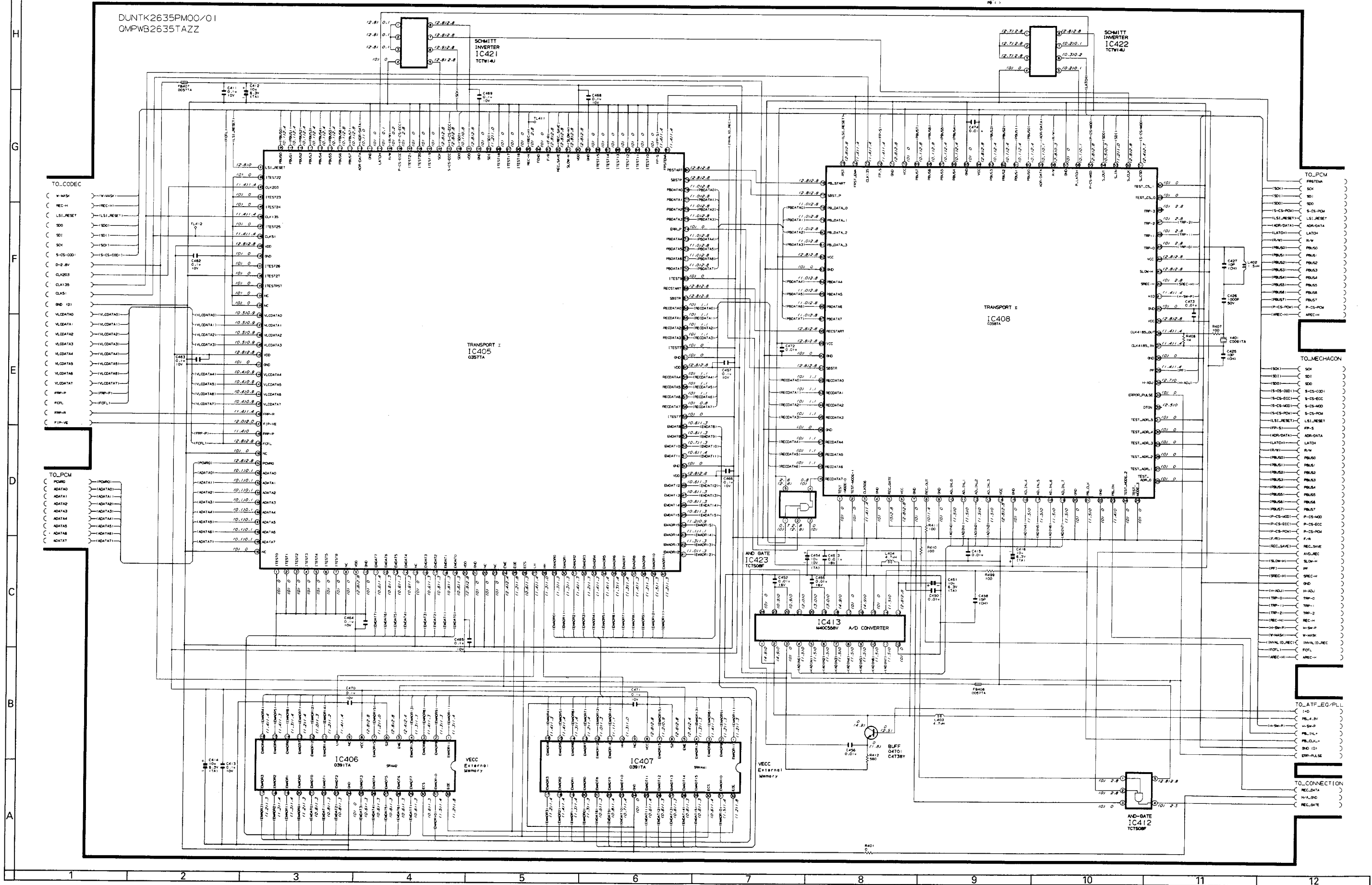

18-2. LCD DISPLAY CIRCUIT SCHEMATIC DIAGRAM / STROMLAUFPLAN DES LCD-DISPLAY-SCHALTKREISES 液晶显示器电路原理图

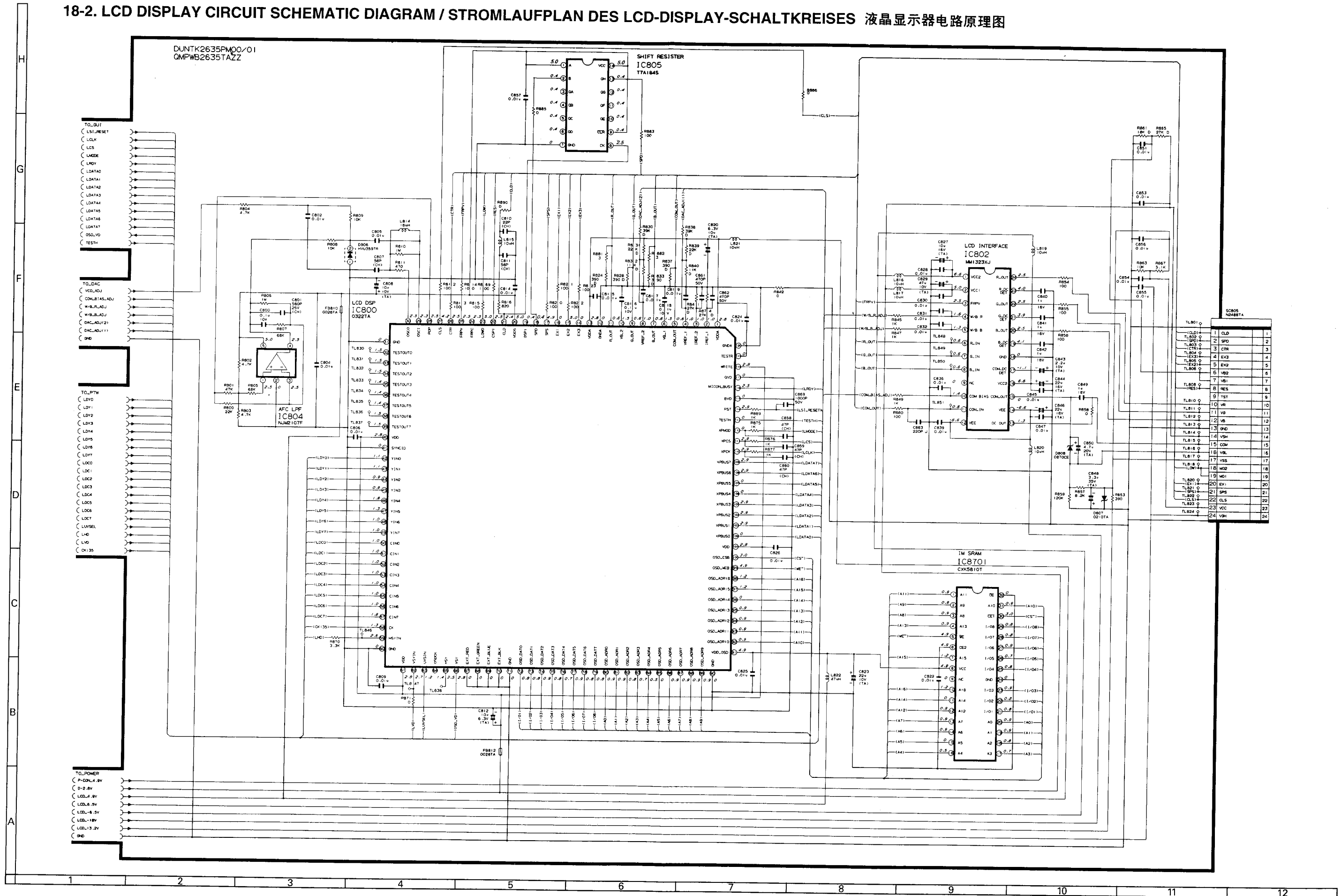

18. VCR-2 CIRCUIT SCHEMATIC DIAGRAM / STROMLAUFPLAN DES VCR-2-SCHALTKREISES 录像机-2电路原理图
 18-1. VIDEO I/O CIRCUIT SCHEMATIC DIAGRAM / STROMLAUFPLAN DES VIDEO-E/A-SCHALTKREISES 视频信号输入/输出电路原理图

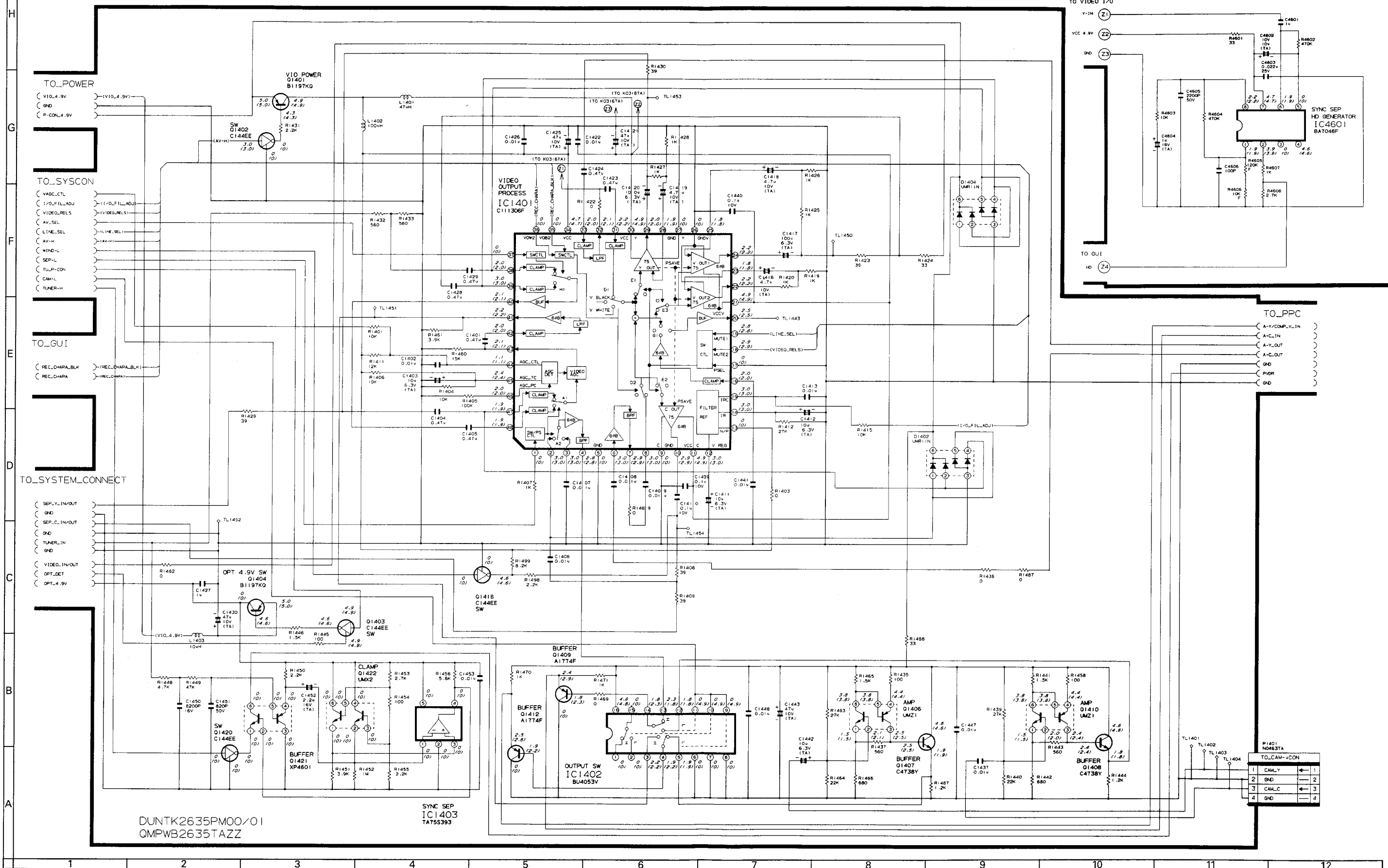

18-6. GUI CIRCUIT SCHEMATIC DIAGRAM / STROMLAUFPLAN DES GUI-SCHALTkreISES GUI 电路原理图

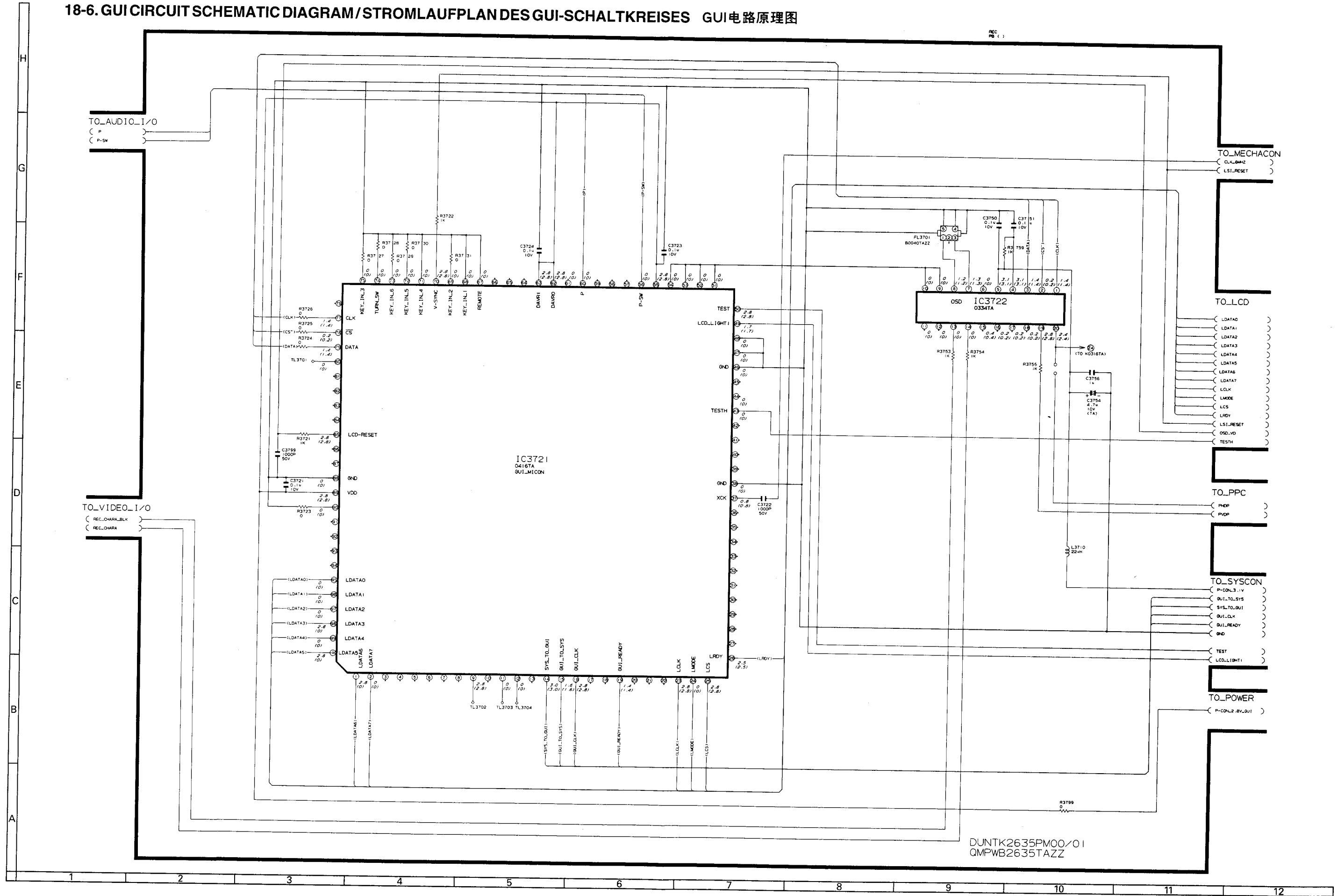

DUNTK2635PM00/01
QMPWB2635TAZZ

18-5. DAC CIRCUIT SCHEMATIC DIAGRAM / STROMLAUFPLAN DES DAC-SCHALTKREISES 数字-模拟转换器电路原理图

REC
PB ()

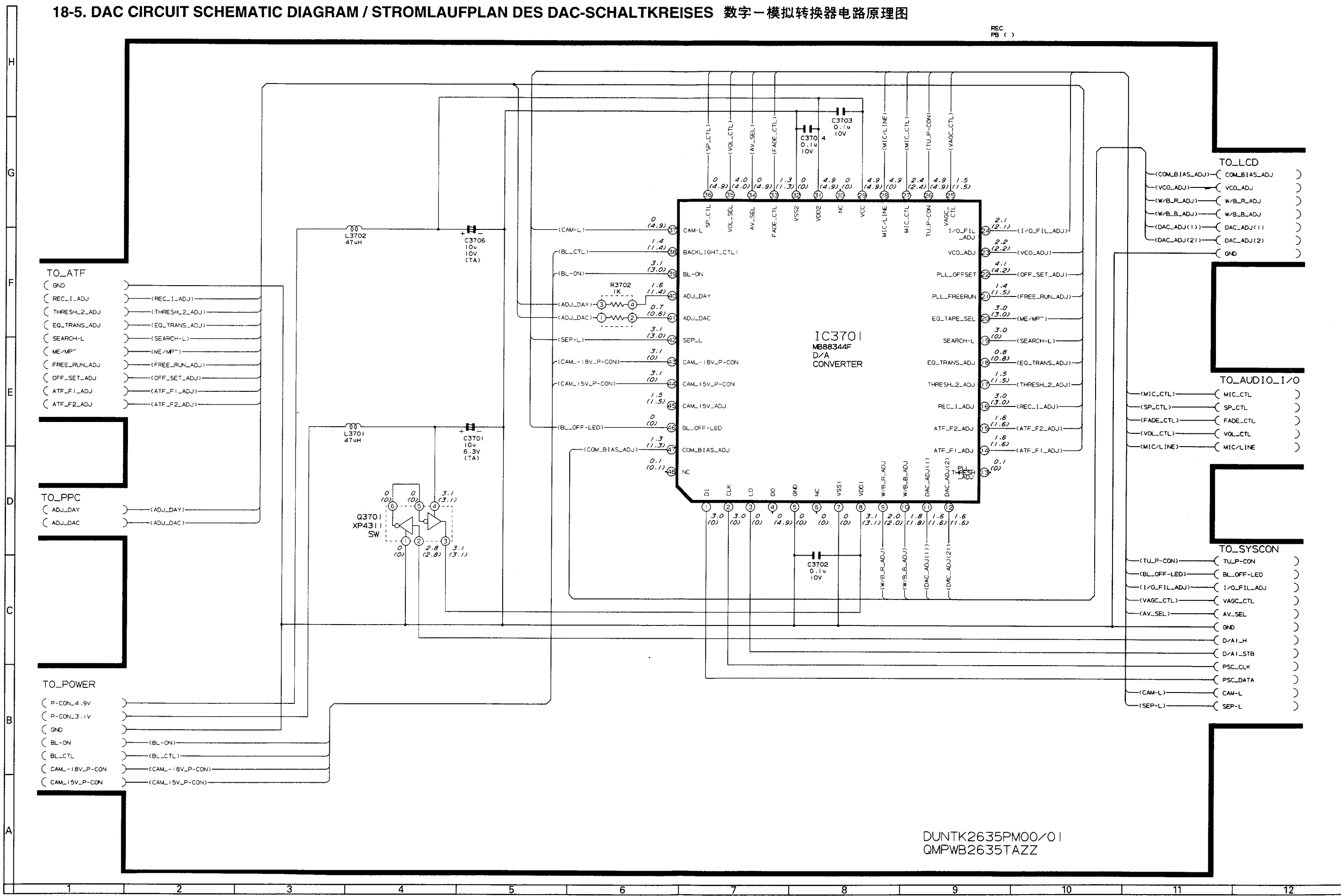

DUNTK2635PM00/O1
QMPWB2635TAZZ

18-7. SYSTEM CONTROLLER POWER CIRCUIT SCHEMATIC DIAGRAM / STROMLAUFPLAN DES SYSTEM-CONTROLLER-LEISTUNGSSCHALTKREISES 系统控制器电源电路原理图

REC
PB ()

DUNTK2635PM00/01
QMPWB2635TAZZ

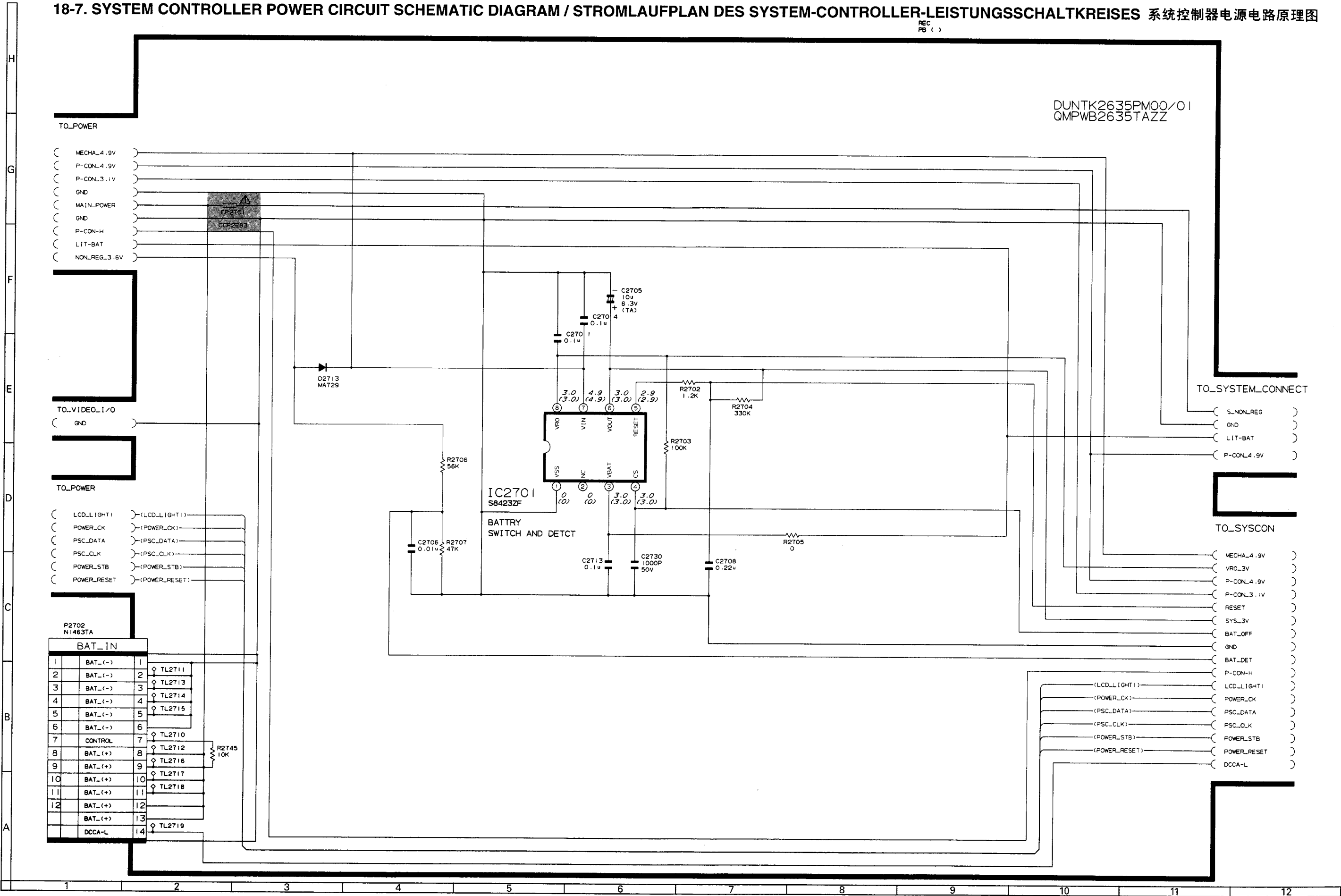

18-10. INTEGRATED SCHEMATIC DIAGRAMS OF POWER CIRCUIT / INTEGRIERTE STROMLAUFPLÄNE DES LEISTUNGSSCHALTKREISES 整体电源电路原理图

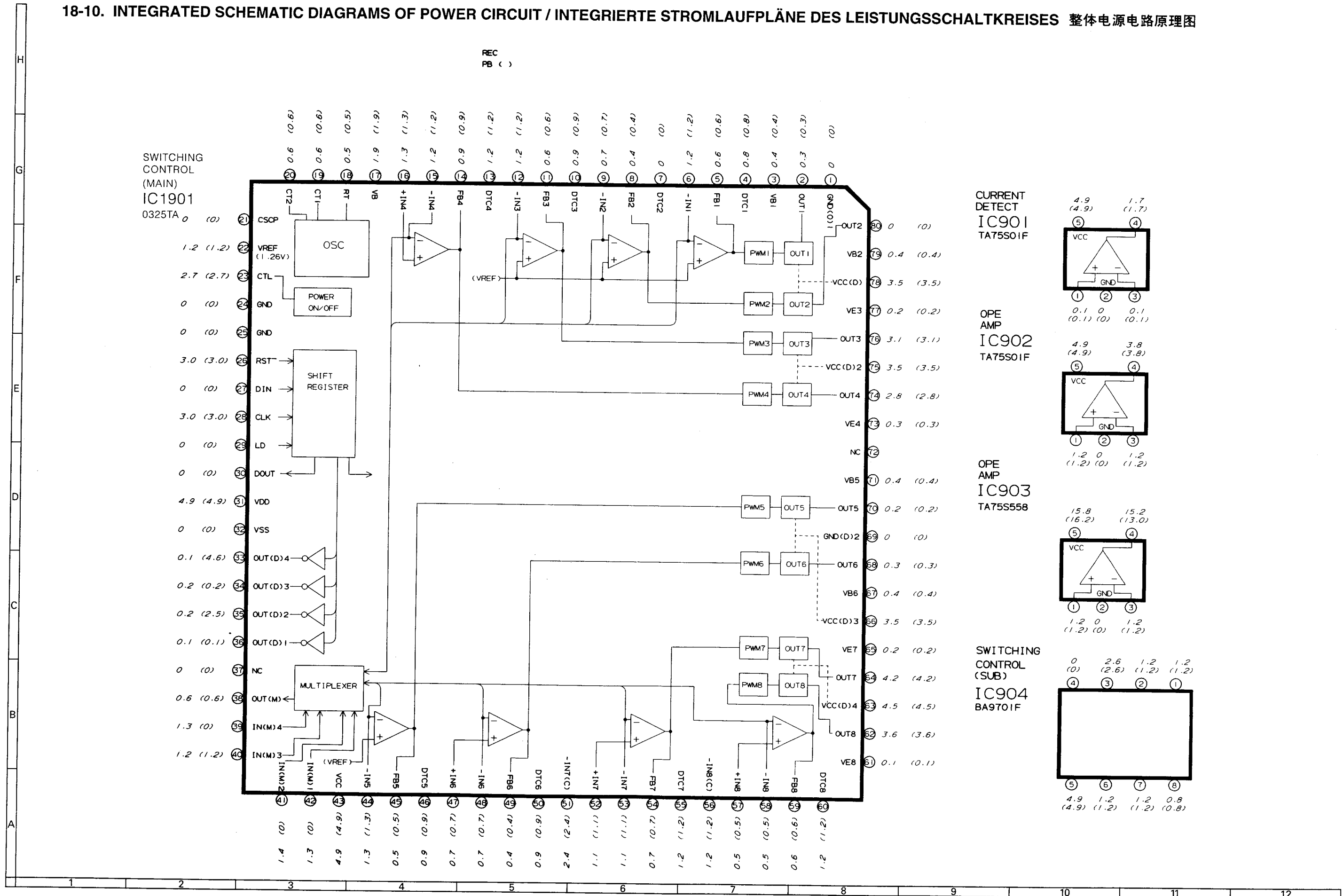

20. PRINTED WIRING BOARD ASSEMBLIES / PLATINEN-EINHEITEN 各印刷电路板的组件

VCR PWB UNIT (SIDE A) /
PWB-EINHEIT DES VCR (SEITE A)
录像机用印刷电路板组件(A面)

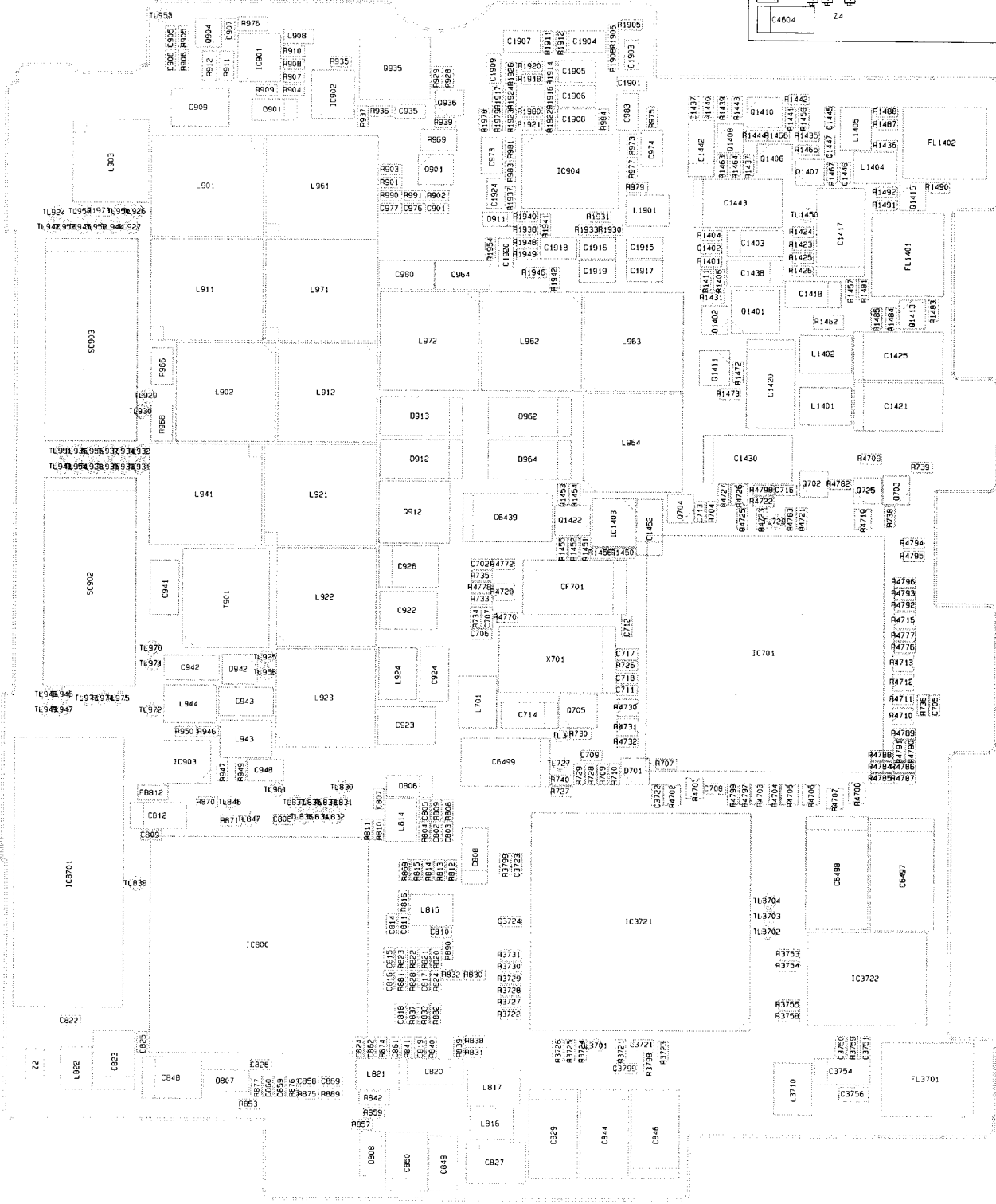

VCR-2

OSD HD GENERATOR PWB UNIT /
PWB-EINHEIT DES OSD HD-GENERATORS
OSD HD信号发生器用印刷电路板组件

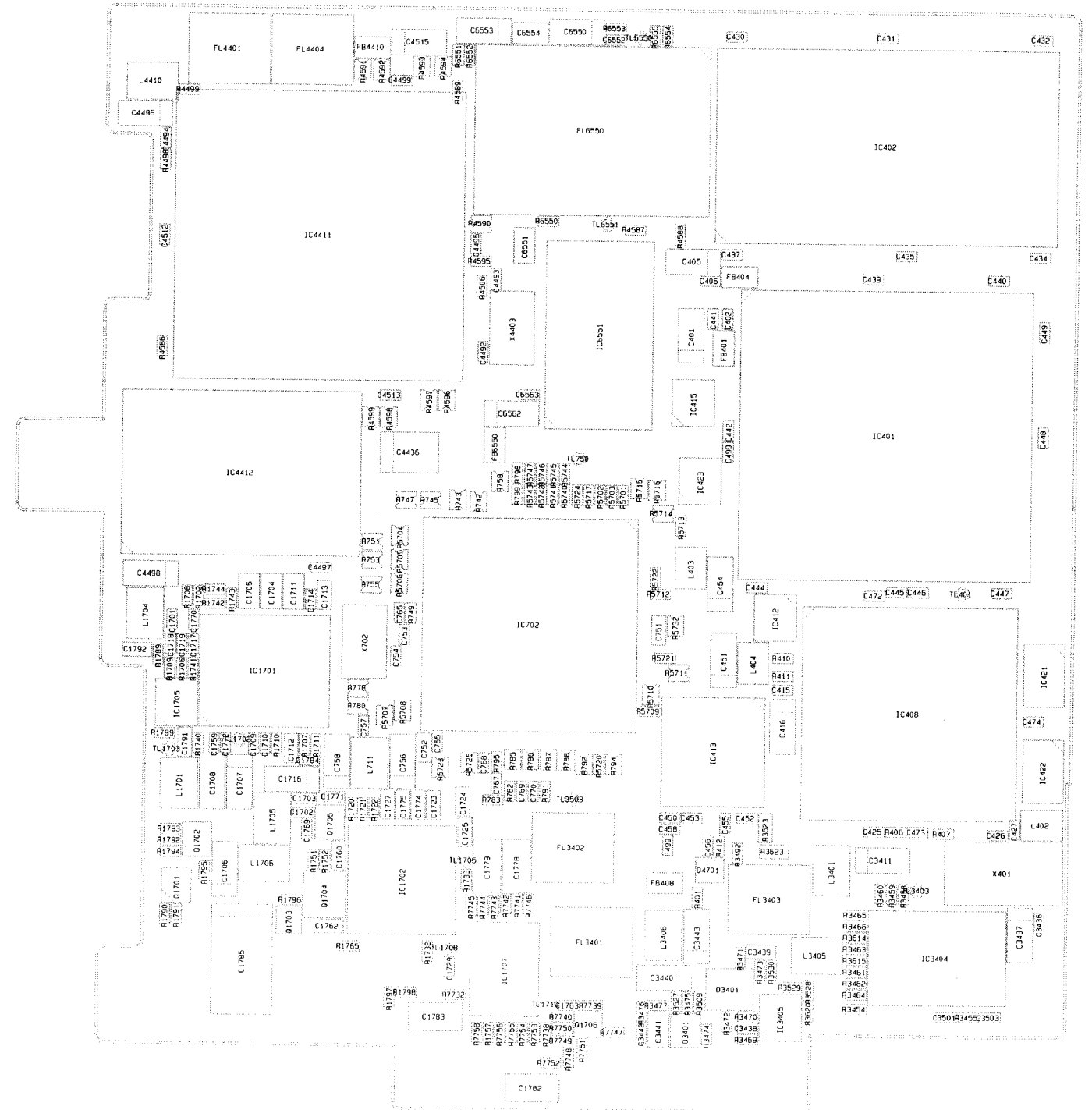

VCR-1

19. MICROPHONE AMPLIFIER CIRCUIT SCHEMATIC DIAGRAM / STROMLAUFPLAN DES MIKROFONVERSTÄRKER-SCHALTKREISES 麦克风放大器电路原理图

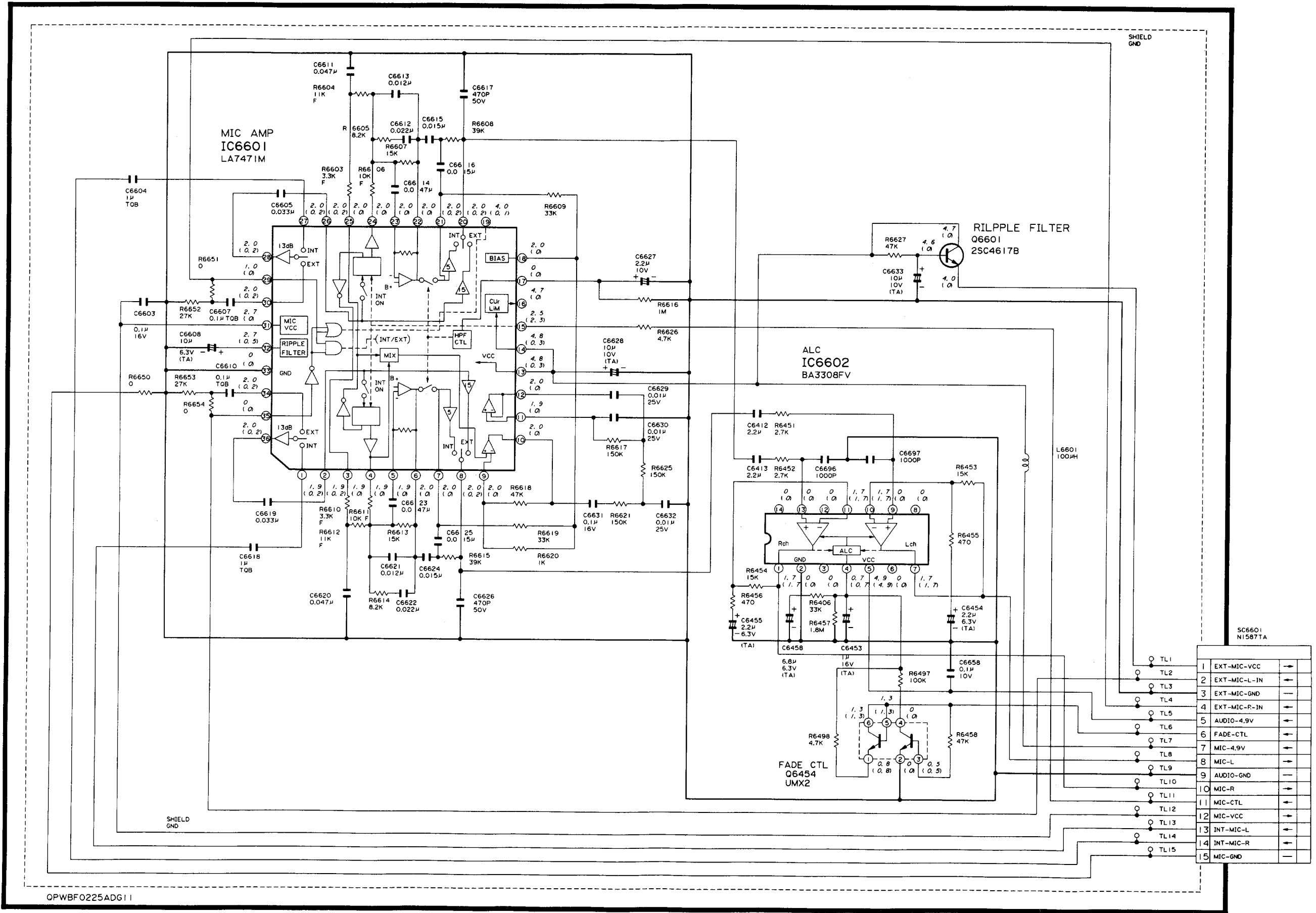

1	EXT-MIC-VCC	→
2	EXT-MIC-L-IN	→
3	EXT-MIC-GND	→
4	EXT-MIC-R-IN	→
5	AUDIO-4.9V	→
6	FADE-CTL	→
7	MIC-4.9V	→
8	MIC-L	→
9	AUDIO-GND	→
10	MIC-R	→
11	MIC-CTL	→
12	MIC-VCC	→
13	INT-MIC-L	→
14	INT-MIC-R	→
15	MIC-GND	→

15. CAM CCD CIRCUIT SCHEMATIC DIAGRAM / STROMLAUFPLAN DES CAM CCD-SCHALTKREISES CAM CCD电路原理图

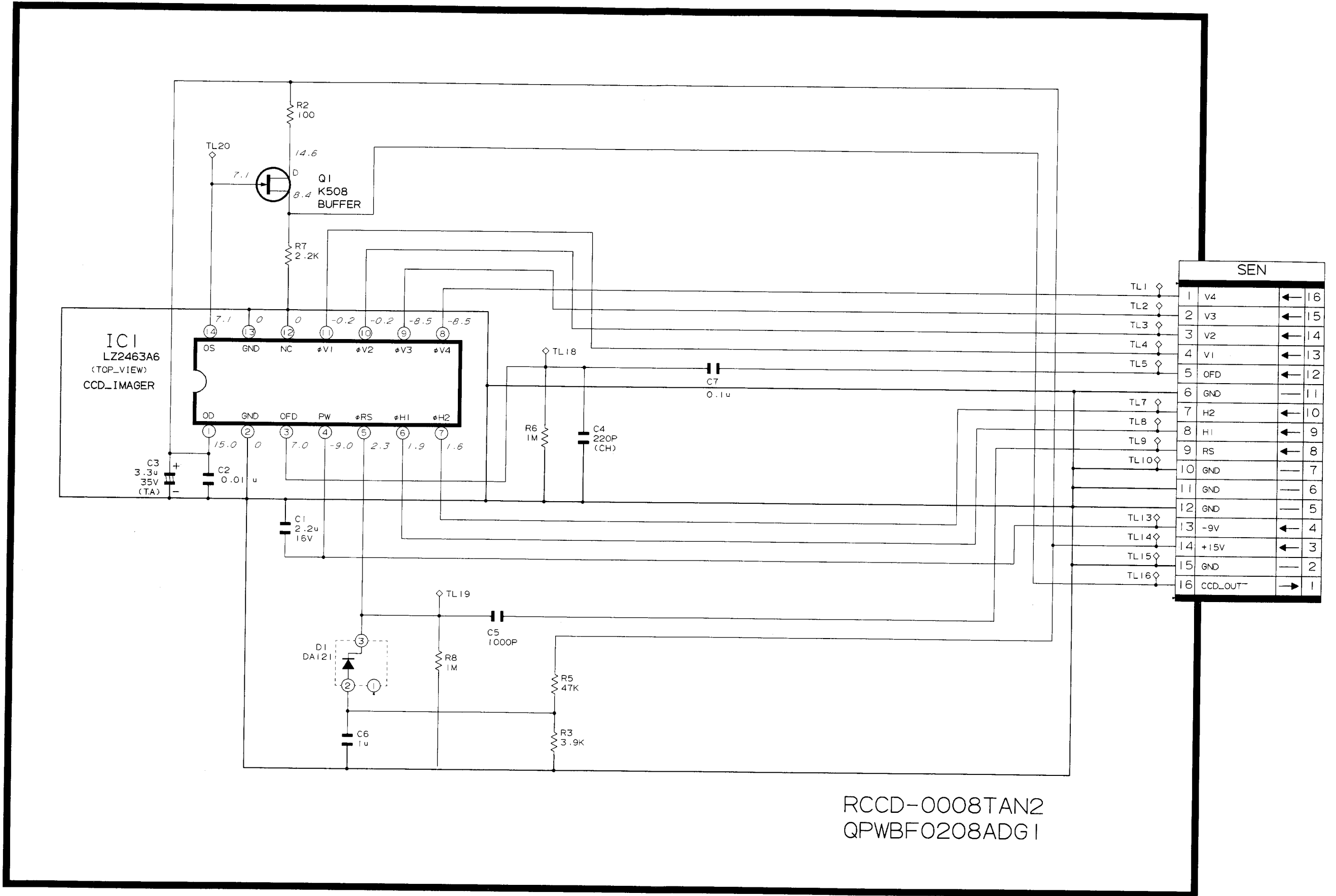

14. HEAD AMPLIFIER CIRCUIT SCHEMATIC DIAGRAM / STROMLAUFPLAN DES VORVERSTÄRKER-SCHALTKREISES 摄影机放大器电路原理图

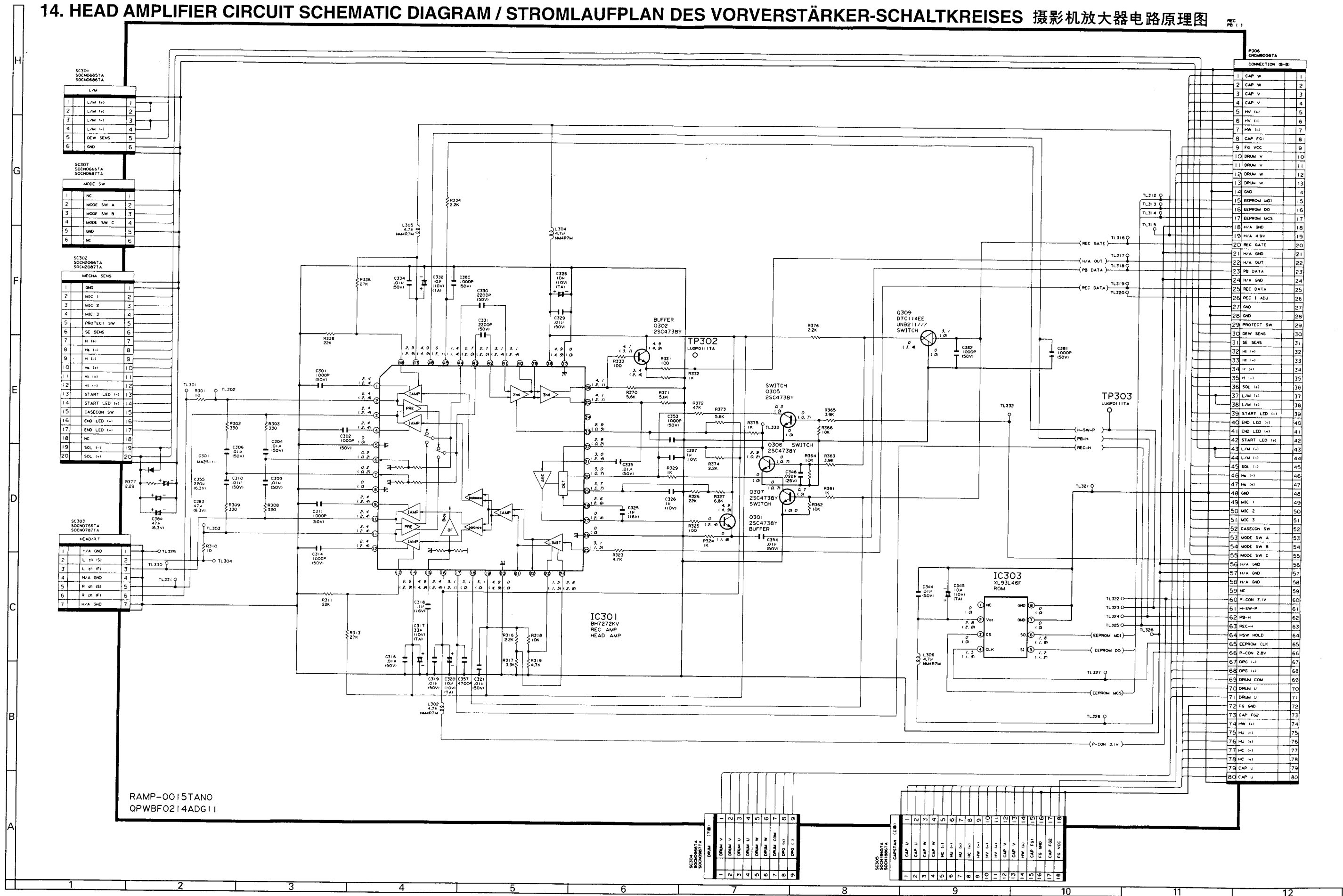

PARTS LIST

PARTS REPLACEMENT

Replacement parts which have these special safety characteristics identified in this manual: electrical components having such features are identified by "△" in the Replacement Parts Lists.

The use of a substitute replacement part which does not have the same safety characteristics as the factory recommended replacement parts shown in this service manual may create shock, fire or other hazards.

"HOW TO ORDER REPLACEMENT PARTS"

To have your order filled promptly and correctly, please furnish the following informations.

- | | |
|-----------------|----------------|
| 1. MODEL NUMBER | 2. REF. NO. |
| 3. PART NO. | 4. DESCRIPTION |
| 5. CODE | 6. QUANTITY |

MARK ★: SPARE PARTS-DELIVERY SECTION

ERSATZTEILLISTE

AUSTAUSCH VON TEILEN

Ersatzteile, die besondere Sicherheitseigenschaften haben, sind in dieser Anleitung markiert. Elektrische Komponenten mit solchen Eigenschaften sind in den Ersatzteil durch "△" gekennzeichnet.

Der Gebrauch von Ersatzteilen, die nicht dieselben Sicherheitseigenschaften haben wie die vom Hersteller empfohlenen und in der Bedienungsanleitung angegebenen, können zur Ursache von Blitzeinschlägen, Bränden und anderen Gefahren werden.

"WIE MAN ERSATZTEILE BESTELLT"

Damit Ihre Bestellung prompt und korrekt ausgeführt wird, geben Sie bitte folgende Informationen.

- | | |
|-------------------|-----------------|
| 1. MODELL NR. | 2. REF. NR. |
| 3. ERSATZTEIL NR. | 4. BESCHREIBUNG |
| 5. KODE | 6. QUANTITÄT |

MARKIERUNG ★: ERSATZTEILE-LIEFERUNG

更换零件表

更换零件

本维修说明书对具有特别安全要求的零件均用标记加以识别。在此更换零件表中，具有特别安全要求的电路元件均用△标记以便注意识别。更换零件时，为了用户的安全以及电视机原有的工作性能，务请使用夏普规定零件。否则，可能有导致触电、火灾或其他不测事故发生的可能。

更换零件的订货方法

为了能迅速而确实地接受订货，以及正确无误地按时交货，在订货时请将下列各项明确告知。

- | | |
|---------|---------|
| 1. 型号 | 2. 参考编号 |
| 3. 零件编号 | 4. 零件名称 |
| 5. 代号 | 6. 数量 |

附★：记号为备用部件的交货部门

Ref. No. Part No. ★ Description Code

PRINTED WIRING BOARD ASSEMBLIES (NOT REPLACEMENT ITEM)

DUNTK2632QA02	-	Camera PWB Unit (VL-DC1E)	—
DUNTK2632QA01	-	Camera PWB Unit (VL-DC1H/S)	—
DUNTK2635QA01	-	VCR PWB Unit (VL-DC1E)	—
DUNTK2635QA00	-	VCR PWB Unit (VL-DC1H/S)	—
RAMP-0015TAN0	-	Head Amp. PWB Unit	—
RAMP-0016TAN0	-	Microphone Amp. PWB Unit	—
RCCD-0008TAN2	-	CCD PWB Unit	—

DUNTK2632QA02/01 CAMERA PWB UNIT

INTEGRATED CIRCUITS

IC11	VHIUPD16510-1	J	V-Driver	AR
IC12	VHILR38511/-1	J	Timing Generator	AQ
IC13	VHINJM79L091E	J	-9V Voltage Regulator	AE
IC101	VHiCXA2006Q-1	J	Corrected Double Sampling AV Video Amp., for AGC	AV
IC102	VHiCXD2310A-1	J	10-bit High-Speed Analog-to-Digital Converter	AV
IC201	RH-IX0323TAZZ	J	Digital Signal Processor HG51D266TE	BF
IC251	RH-IX0394TAZZ	J	Electric Zoom Emage Stabilizer	BB
IC252	VHIMS548331-1	J	Field Memory	BD
IC253	VHIMS548331-1	J	Field Memory	BD
IC501	RH-IX0400TAZZ	J	Microprocessor	AY
IC502	VHiMB8346BV-1	J	8-bit Digital-to-Analog Converter	AN
IC503	VHiS24C02A/-1	J	EEPROM	AK
IC504	VHiPST592KM-1	J	Watching Power Reset	AF
IC551	VHiMM1299XQ-1	J	Lens Driver	AV

TRANSISTORS

Q11	VSUMX2/////1	J	3.6V Voltage Regulator	AB
Q101	VS2SC4617B/-1	J	Buffer	AA
Q201	VS2SC4617B/-1	J	Buffer	AA
Q202	VS2SC4617B/-1	J	Buffer	AA
Q204	VS2SC4617B/-1	J	Buffer	AA
Q205	VSUMZ1/////1	J	Amplifier	AB
Q206	VSUMZ1/////1	J	Amplifier	AB
Q551	VS2SC4617B/-1	J	Iris Meter Driver	AA
Q552	VSUMT2/////1	J	Hall Device Regulator	AB

DIODES

D11	VHDDA121///-1	J	Diode DA121	AA
D501	VHDDA121///-1	J	Diode DA121	AA

Ref. No.	Part No.	★	Description	Code	Ref. No.	Part No.	★	Description	Code
DUNTK2632QA02/01									
CAMERA PWB UNIT (Continued)									
PACKAGED CIRCUIT									
X11	RCRSZ0028TAZZ	J	Crystal	AQ	C121	VCSATA0JJ156M	J 15	6.3V Tantalum	AC
COIL AND TRANSFORMERS									
CF501	RFILC0060TAZZ	J	Ceramic Filter	AF	C122	VCKYCZ1AF104Z	J 0.1	10V Ceramic	AB
FL13	RFILN0002TAZZ	J	Filter	AF	C201	VCSATA0JJ156M	J 15	6.3V Tantalum	AC
FL201	RCILF0347TAZZ	J	Filter	AL	C202	VCKYCZ1HF103Z	J 0.01	50V Ceramic	AB
FL202	RCILF0353TAZZ	J	Filter	AK	C203	VCSATA0JJ156M	J 15	6.3V Tantalum	AC
L11	VPAXM470K1R7N	J	Peaking Coil 47μH	AC	C204	VCKYCZ1HF103Z	J 0.01	50V Ceramic	AB
L12	VPAXM100KR42N	J	Peaking Coil 10μH	AC	C205	VCKYCZ1HB222K	J 2200p	50V Ceramic	AB
L101	VPAXM100KR42N	J	Peaking Coil 10μH	AC	C206	VCKYCZ1AF104Z	J 0.1	10V Ceramic	AB
L102	VPAXM470K1R7N	J	Peaking Coil 47μH	AC	C207	VCKYCZ1AF104Z	J 0.1	10V Ceramic	AB
L201	VPAXM100KR42N	J	Peaking Coil 10μH	AC	C208	VCKYCZ1AF104Z	J 0.1	10V Ceramic	AB
L202	VPAXM470K1R7N	J	Peaking Coil 47μH	AC	C209	VCKYCZ1AF104Z	J 0.1	10V Ceramic	AB
L203	VPAXM100KR42N	J	Peaking Coil 10μH	AC	C210	VCKYCZ1HB222K	J 2200p	50V Ceramic	AB
L251	VPAXM100KR42N	J	Peaking Coil 10μH	AC	C211	VCKYCZ1HF103Z	J 0.01	50V Ceramic	AB
L252	VPAXM100KR42N	J	Peaking Coil 10μH	AC	C212	VCSATA0JJ156M	J 15	6.3V Tantalum	AC
L501	VPAXM100KR42N	J	Peaking Coil 10μH	AC	C213	VCKYCZ1HF103Z	J 0.01	50V Ceramic	AB
L502	VPAXM100KR42N	J	Peaking Coil 10μH	AC	C214	VCKYCZ1HF103Z	J 0.01	50V Ceramic	AB
CAPACITORS									
C11	VCSATC1VJ685M	J 6.8	35V Tantalum	AF	C215	VCSATE1AJ226M	J 22	10V Tantalum	AD
C12	VCKYCZ1HF103Z	J 0.01	50V Ceramic	AB	C216	VCKYCZ1HF103Z	J 0.01	50V Ceramic	AB
C13	VCSATE1DJ475M	J 4.7	20V Tantalum	AD	C217	VCSATC1AJ476M	J 47	10V Tantalum	AE
C14	VCKYCZ1HF103Z	J 0.01	50V Ceramic	AB	C218	VCKYCZ1HF103Z	J 0.01	50V Ceramic	AB
C15	VCKYCZ1HF103Z	J 0.01	50V Ceramic	AB	C220	VCKYCZ1AF104Z	J 0.1	10V Ceramic	AB
C16	VCKYCZ1HF103Z	J 0.01	50V Ceramic	AB	C221	VCKYCZ1AF104Z	J 0.1	10V Ceramic	AB
C17	VCSATA1AJ106M	J 10	10V Tantalum	AC	C251	VCSATA0JJ156M	J 15	6.3V Tantalum	AC
C18	VCKYCZ1HF103Z	J 0.01	50V Ceramic	AB	C252	VCKYCZ1HF103Z	J 0.01	50V Ceramic	AB
C19	VCSATA0JJ156M	J 15	6.3V Tantalum	AC	C253	VCKYCZ1AF104Z	J 0.1	10V Ceramic	AB
C20	VCKYCZ1HB102K	J 1000p	50V Ceramic	AB	C254	VCKYCZ1HF103Z	J 0.01	50V Ceramic	AB
C21	VCCCCZ1HH6R0D	J 6p	50V Ceramic	AA	C255	VCKYCZ1AF104Z	J 0.1	10V Ceramic	AB
C22	VCKYCZ1HF103Z	J 0.01	50V Ceramic	AB	C256	VCKYCZ1HF103Z	J 0.01	50V Ceramic	AB
C23	VCSATA1AJ106M	J 10	10V Tantalum	AC	C258	VCKYCZ1HF103Z	J 0.01	50V Ceramic	AB
C24	VCKYCZ1HB102K	J 1000p	50V Ceramic	AB	C259	VCSATA0JJ156M	J 15	6.3V Tantalum	AC
C25	VCKYCZ1HF103Z	J 0.01	50V Ceramic	AB	C260	VCKYCZ1HF103Z	J 0.01	50V Ceramic	AB
C26	VCKYCZ1AF104Z	J 0.1	10V Ceramic	AB	C261	VCKYCZ1HF103Z	J 0.01	50V Ceramic	AB
C101	VCKYTQ1CB105K	J 1	16V Ceramic	AC	C501	VCKYCZ1HF103Z	J 0.01	50V Ceramic	AB
C102	VCKYTQ1CB105K	J 1	16V Ceramic	AC	C502	VCSATA1AJ106M	J 10	10V Tantalum	AC
C103	VCSATA1AJ106M	J 10	10V Tantalum	AC	C503	VCKYCZ1AF104Z	J 0.1	10V Ceramic	AB
C104	VCKYCZ1HF103Z	J 0.01	50V Ceramic	AB	C504	VCKYCZ1AF104Z	J 0.1	10V Ceramic	AB
C105	VCKYCZ1HF103Z	J 0.01	50V Ceramic	AB	C505	VCKYCZ1AF104Z	J 0.1	10V Ceramic	AB
C106	VCKYCZ1EF223Z	J 0.022	25V Ceramic	AB	C506	VCKYCZ1HF103Z	J 0.01	50V Ceramic	AB
C107	VCKYCZ1HF103Z	J 0.01	50V Ceramic	AB	C551	VCSATE1AJ156M	J 15	10V Tantalum	AD
C108	VCKYCZ1AF104Z	J 0.1	10V Ceramic	AB	C552	VCSATE1AJ156M	J 15	10V Tantalum	AD
C109	VCKYCY1CF104Z	J 0.1	16V Ceramic	AA	C553	VCKYCZ1HF103Z	J 0.01	50V Ceramic	AB
C110	VCKYCY1CF104Z	J 0.1	16V Ceramic	AA	C554	VCKYCZ1HF103Z	J 0.01	50V Ceramic	AB
C111	VCKYCZ1AF104Z	J 0.1	10V Ceramic	AB	C555	VCSATA1AJ475M	J 4.7	10V Tantalum	AC
C113	VCCCCZ1HH470J	J 47p	50V Ceramic	AB	C556	VCKYCY1CB333K	J 0.033	16V Ceramic	AA
C114	VCKYCZ1AF104Z	J 0.1	10V Ceramic	AB	C557	VCKYCY1CF224Z	J 0.22	16V Ceramic	AA
C115	VCKYCZ1HF103Z	J 0.01	50V Ceramic	AB	C558	VCKYCY1HB122K	J 1200p	50V Ceramic	AA
C116	VCKYCZ1HF103Z	J 0.01	50V Ceramic	AB	C559	VCKYCZ1HF103Z	J 0.01	50V Ceramic	AB
C120	VCSATA1AJ106M	J 10	10V Tantalum	AC	C560	VCKYCZ1HF103Z	J 0.01	50V Ceramic	AB
					C561	VCSATA1AJ475M	J 4.7	10V Tantalum	AC
					C562	VCKYCY1HB472K	J 4700p	50V Ceramic	AA
					C563	VCKYCY1HB472K	J 4700p	50V Ceramic	AA
					C564	VCKYCY1HB472K	J 4700p	50V Ceramic	AA
					C565	VCKYCY1HB103K	J 0.01	50V Ceramic	AA
					C566	VCKYCY1HB472K	J 4700p	50V Ceramic	AA
					C567	VCKYCY1EB183K	J 0.018	25V Ceramic	AA
					C568	VCKYCZ1HF103Z	J 0.01	50V Ceramic	AB

Ref. No.	Part No.	★	Description	Code	Ref. No.	Part No.	★	Description	Code
DUNTK2632QA02/01									
CAMERA PWB UNIT (Continued)									
RESISTORS									
R11	VRS-CZ1JF222J	J	2.2k 1/16W Metal Oxide	AA	R256	VRS-CZ1JF102J	J	1k 1/16W Metal Oxide	AA
R12	VRS-CZ1JF183J	J	18k 1/16W Metal Oxide	AA	R257	VRS-CZ1JF330J	J	33 1/16W Metal Oxide	AA
R13	VRS-CZ1JF105J	J	1M 1/16W Metal Oxide	AA	R258	VRS-CZ1JF330J	J	33 1/16W Metal Oxide	AA
R14	VRS-CZ1JF330J	J	33 1/16W Metal Oxide	AA	R259	VRS-CZ1JF330J	J	33 1/16W Metal Oxide	AA
R15	VRS-CZ1JF000J	J	0 1/16W Metal Oxide	AA	R260	VRS-CZ1JF103J	J	10k 1/16W Metal Oxide	AA
R16	VRS-CZ1JF000J	J	0 1/16W Metal Oxide	AA	R502	VRS-CZ1JF102J	J	1k 1/16W Metal Oxide	AA
R17	VRS-CZ1JF000J	J	0 1/16W Metal Oxide	AA	R503	VRS-CZ1JF000J	J	0 1/16W Metal Oxide	AA
R18	VRS-CZ1JF561J	J	560 1/16W Metal Oxide	AA	R504	VRS-CZ1JF222J	J	2.2k 1/16W Metal Oxide	AA
R21	VRS-CZ1JF102J	J	1k 1/16W Metal Oxide	AA	R505	VRS-CZ1JF222J	J	2.2k 1/16W Metal Oxide	AA
R31	VRS-CY1JF000J	J	0 1/16W Metal Oxide	AA	R506	VRS-CZ1JF102J	J	1k 1/16W Metal Oxide	AA
R34	VRS-CY1JF000J	J	0 1/16W Metal Oxide	AA	R507	VRS-CZ1JF102J	J	1k 1/16W Metal Oxide	AA
R101	VRS-CZ1JF153D	J	15k 1/16W Metal Oxide	AB	R508	VRS-CZ1JF102J	J	1k 1/16W Metal Oxide	AA
R102	VRS-CZ1JF244F	J	240k 1/16W Metal Oxide	AA	R509	VRS-CZ1JF103J	J	10k 1/16W Metal Oxide	AA
R103	VRS-CZ1JF102J	J	1k 1/16W Metal Oxide	AA	R510	VRS-CZ1JF000J	J	0 1/16W Metal Oxide	AA
R104	VRS-CZ1JF122J	J	1.2k 1/16W Metal Oxide	AA	R512	VRS-CZ1JF222J	J	2.2k 1/16W Metal Oxide	AA
R105	VRS-CZ1JF682J	J	6.8k 1/16W Metal Oxide	AA	R513	VRS-CZ1JF102J	J	1k 1/16W Metal Oxide	AA
R106	VRS-CZ1JF393J	J	39k 1/16W Metal Oxide	AA	R514	VRS-CZ1JF223J	J	22k 1/16W Metal Oxide	AA
R107	VRS-CZ1JF333J	J	33k 1/16W Metal Oxide	AA	R515	VRS-CZ1JF102J	J	1k 1/16W Metal Oxide	AA
R108	VRS-CZ1JF000J	J	0 1/16W Metal Oxide	AA	R516	VRS-CZ1JF103J	J	10k 1/16W Metal Oxide	AA
R109	VRS-CZ1JF220J	J	22 1/16W Metal Oxide	AA	R517	VRS-CZ1JF224J	J	220k 1/16W Metal Oxide	AA
R110	VRS-CZ1JF104J	J	100k 1/16W Metal Oxide	AA	R518	VRS-CZ1JF224J	J	220k 1/16W Metal Oxide	AA
R114	VRS-CZ1JF273J	J	27k 1/16W Metal Oxide	AA	R519	VRS-CZ1JF102J	J	1k 1/16W Metal Oxide	AA
R201	VRS-CZ1JF392J	J	3.9k 1/16W Metal Oxide	AA	R520	VRS-CZ1JF102J	J	1k 1/16W Metal Oxide	AA
R202	VRS-CZ1JF392J	J	3.9k 1/16W Metal Oxide	AA	R521	VRS-CZ1JF102J	J	1k 1/16W Metal Oxide	AA
R203	VRS-CZ1JF331J	J	330 1/16W Metal Oxide	AA	R522	VRS-CZ1JF102J	J	1k 1/16W Metal Oxide	AA
R204	VRS-CZ1JF391J	J	390 1/16W Metal Oxide	AA	R523	VRS-CZ1JF102J	J	1k 1/16W Metal Oxide	AA
R205	VRS-CZ1JF562J	J	5.6k 1/16W Metal Oxide	AA	R524	VRS-CZ1JF102J	J	1k 1/16W Metal Oxide	AA
R206	VRS-CZ1JF683J	J	68k 1/16W Metal Oxide	AA	R525	VRS-CY1JF000J	J	0 1/16W Metal Oxide	AA
R207	VRS-CZ1JF102J	J	1k 1/16W Metal Oxide	AA	R526	VRS-CY1JF000J	J	0 1/16W Metal Oxide	AA
R208	VRS-CZ1JF103J	J	10k 1/16W Metal Oxide	AA	R528	VRS-CZ1JF000J	J	0 1/16W Metal Oxide	AA
R209	VRS-CZ1JF102J	J	1k 1/16W Metal Oxide	AA	R529	VRS-CY1JF000J	J	0 1/16W Metal Oxide	AA
R210	VRS-CZ1JF102J	J	1k 1/16W Metal Oxide	AA	R530	VRS-CZ1JF103J	J	10k 1/16W Metal Oxide	AA
R211	VRS-CZ1JF102J	J	1k 1/16W Metal Oxide	AA				(VL-DC1E)	
R212	VRS-CZ1JF101J	J	100 1/16W Metal Oxide	AA	R531	VRS-CZ1JF103J	J	10k 1/16W Metal Oxide	AA
R213	VRS-CZ1JF182J	J	1.8k 1/16W Metal Oxide	AA				(VL-DC1H/S)	
R214	VRS-CZ1JF102J	J	1k 1/16W Metal Oxide	AA	R532	VRS-CZ1JF102J	J	1k 1/16W Metal Oxide	AA
R215	VRS-CZ1JF333J	J	33k 1/16W Metal Oxide	AA	R533	VRS-CZ1JF223J	J	22k 1/16W Metal Oxide	AA
R216	VRS-CZ1JF153J	J	15k 1/16W Metal Oxide	AA	R534	VRS-CZ1JF103J	J	10k 1/16W Metal Oxide	AA
R217	VRS-CZ1JF561J	J	560 1/16W Metal Oxide	AA	R535	VRS-CY1JF223J	J	22k 1/16W Metal Oxide	AA
R219	VRS-CZ1JF122J	J	1.2k 1/16W Metal Oxide	AA	R536	VRS-CZ1JF102J	J	1k 1/16W Metal Oxide	AA
R220	VRS-CZ1JF102J	J	1k 1/16W Metal Oxide	AA	R551	VRS-CZ1JF105J	J	1M 1/16W Metal Oxide	AA
R221	VRS-CZ1JF101J	J	100 1/16W Metal Oxide	AA	R552	VRS-CZ1JF332J	J	3.3k 1/16W Metal Oxide	AA
R222	VRS-CZ1JF272J	J	2.7k 1/16W Metal Oxide	AA	R553	VRS-CZ1JF682J	J	6.8k 1/16W Metal Oxide	AA
R223	VRS-CZ1JF821J	J	820 1/16W Metal Oxide	AA	R554	VRS-CZ1JF682J	J	6.8k 1/16W Metal Oxide	AA
R224	VRS-CZ1JF152J	J	1.5k 1/16W Metal Oxide	AA	R555	VRS-CZ1JF153D	J	15k 1/16W Metal Oxide	AB
R225	VRS-CZ1JF683J	J	68k 1/16W Metal Oxide	AA	R556	VRS-CZ1JF244F	J	240k 1/16W Metal Oxide	AA
R226	VRS-CZ1JF683J	J	68k 1/16W Metal Oxide	AA	R557	VRS-CZ1JF103J	J	10k 1/16W Metal Oxide	AA
R227	VRS-CZ1JF000J	J	0 1/16W Metal Oxide	AA	R558	VRS-CZ1JF392J	J	3.9k 1/16W Metal Oxide	AA
R251	VRS-CZ1JF103J	J	10k 1/16W Metal Oxide	AA	R559	VRS-CZ1JF103J	J	10k 1/16W Metal Oxide	AA
R253	VRS-CZ1JF330J	J	33 1/16W Metal Oxide	AA	R560	VRS-CZ1JF392J	J	3.9k 1/16W Metal Oxide	AA
R254	VRS-CZ1JF330J	J	33 1/16W Metal Oxide	AA	R561	VRS-CZ1JF180J	J	18 1/16W Metal Oxide	AA
R255	VRS-CZ1JF330J	J	33 1/16W Metal Oxide	AA	R562	VRS-CZ1JF223J	J	22k 1/16W Metal Oxide	AA
					R564	VRS-CZ1JF222J	J	2.2k 1/16W Metal Oxide	AA
					R565	VRS-CZ1JF121J	J	120 1/16W Metal Oxide	AA
					R566	VRS-CZ1JF121J	J	120 1/16W Metal Oxide	AA
					R567	VRS-CZ1JF103D	J	10k 1/16W Metal Oxide	AB

Ref. No.	Part No.	★	Description	Code	Ref. No.	Part No.	★	Description	Code
DUNTK2632QA02/01					DUNTK2635QA01/00				
CAMERA PWB UNIT (Continued)					VCR PWB UNIT				
MISCELLANEOUS PARTS					INTEGRATED CIRCUITS				
R568	VRS-CZ1JF103D	J	10k 1/16W Metal Oxide	AB	IC401	RH-IX0407TAZZ	J	Shuffling Discrete Cosine Transform	BL
R569	VRS-CZ1JF104D	J	100k 1/16W Metal Oxide	AB	IC402	RH-IX0265TAZZ	J	Shuffling Memory LH6V5160N	BN
R570	VRS-CZ1JF103J	J	10k 1/16W Metal Oxide	AA	IC403	RH-IX0370TAZZ	J	Compression Expansion	BL
R571	VRS-CZ1JF473D	J	47k 1/16W Metal Oxide	AB	IC404	RH-IX0391TAZZ	J	External Memory	BC
R578	VRS-CZ1JF153J	J	15k 1/16W Metal Oxide	AA	IC405	RH-IX0357TAZZ	J	Transport 1	BL
R580	VRS-CZ1JF104J	J	100k 1/16W Metal Oxide	AA	IC406	RH-IX0391TAZZ	J	External Memory	BC
R599	VRS-CY1JF000J	J	0 1/16W Metal Oxide	AA	IC407	RH-IX0391TAZZ	J	External Memory	BC
P1	QPLGN0363TAZZ	J	Plug 3-pin	AC	IC408	RH-IX0358TAZZ	J	Transport 1, LZ9HT19	BQ
P2	QPLGN0263TAZZ	J	Plug 2-pin	AB	IC412	VHITC7S08F/-1	J	AND Gate	AC
P6	QCNCM2052TAZZ	J	Connector 20-pin	AE	IC413	VHIM40C558V-1	J	A/D Converter	AX
P201	QPLGN0463TAZZ	J	Plug 4-pin	AC	IC415	VHITC7S08F/-1	J	AND Gate	AC
SC2	QSOCN1687TAZZ	J	Socket 16-pin	AD	IC420	VHITC7W74U/-1	J	Schmitt Inverter	AD
SC3	QSOCN2087TAZZ	J	Socket 20-pin	AE	IC421	VHITC7W14U/-1	J	Schmitt Inverter	AG
SC4	QSOCN1987TAZZ	J	Socket 19-pin	AE	IC422	VHITC7W14U/-1	J	Schmitt Inverter	AG
SC5	QSOCN0860TAZZ	J	Socket 8-pin	AE	IC423	VHITC7S08F/-1	J	AND Gate	AC
SC8	QSOCN3087TAZZ	J	Socket 30-pin	AF	IC701	RH-IX0409TAZZ	J	System Control Micon	AY
SLD1	PSLDM3243TAFW	J	Camera Shield-A	AE	IC702	RH-IX0415TAZZ	J	Mecha. Control Micon	AZ
SLD2	PSLDM3244TAFW	J	Camera Shield-B	AD	IC703	VHINJM2902V-1	J	Drum/Capstan Error Amp.	AD
					IC706	VHiXL93L46F-1	J	EEPROM	AG
					IC800	RH-IX0322TAZZ	J	LCD DSP, LR38291	BD
					IC802	VHiMM1323XJ-1	J	LCD Interface	AT
					IC804	VHINJM2107F-1	J	AFC LPF	AE
					IC805	VHiT7A164S/-1	J	Shift Register	AL
					IC901	VHiTA75S01F-1	J	Current Detect	AD
					IC902	VHiTA75S01F-1	J	Current Detect	AD
					IC903	VHiTA75S558-1	J	Ope. Amp.	AE
					IC904	VHiBA9701F/-1	J	Sub-Switching Control	AF
					IC1401	VHiC111306F-1	J	Video Output Process	AX
					IC1402	VHiBU4053V/-1	J	Output Switch	AE
					IC1403	VHiTA75S393-1	J	TA75S393F	AC
					IC1701	VHiLB1950V/-1	J	Drum Motor Driver	AQ
					IC1702	VHiLB1951V/-1	J	Capstan Motor Driver	AN
					IC1703	VHiLB1638M/-1	J	Loading Motor Driver	AK
					IC1705	VHiTA75S393-1	J	Drum FG Amp.	AC
					IC1706	VHINJM2901V-1	J	Reel Sensor Amp.	AD
					IC1707	VHINJM2112V-1	J	Reel Sensor Amp.	AF
					IC1901	RH-IX0325TAZZ	J	Main Switching Control MB4484PFV-G	AY
					IC2701	VHiS8423ZF/-1	J	Battery Switch and Detect	AN
					IC3401	VHiBH7268KV-1	J	PLL	BB
					IC3402	VHiBH7273KV-1	J	EQ/ATF	BA
					IC3404	VHiTA8517///-1	J	Comparator	AV
					IC3405	VHiTA75S01F-1	J	Amp.	AD
					IC3701	VHiMB88344F-1	J	D/A Converter	AV
					IC3721	RH-IX0416TAZZ	J	GUI Micon	AW
					IC3722	RH-IX0334TAZZ	J	OSD, UPD6462GS-615	AP
					IC4401	RH-IX0372TAZZ	J	Digital Decoder	BM
					IC4411	RH-IX0419TAZZ	J	Sync./Clock Generator	BE
					IC6401	VHiTC4W66U/-1	J	I/O Switch	AF
					IC6403	VHiTA75W5581E	J	Amplifier	AE

Ref. No.	Part No.	★	Description	Code	Ref. No.	Part No.	★	Description	Code
DUNTK2635QA01/00									
VCR PWB UNIT (Continued)									
IC6404	VHiBA7785FS-1	J	SP/HP Amplifier	AN	Q1422	VSUMX2/////1	J		AB
IC6406	VHiBU4053V/-1	J	I/O Switch	AE	Q1701	VSUMX2/////1	J	S/E LED Driver	AB
IC6501	VHiAK4504/-1	J	ADC/DAC	AZ	Q1702	VSUMB2/////1	J	S/E LED Driver	AB
IC6502	VHiTK10625M-1	J	Inverter/Buffer	AH	Q1703	VSUN9111///-1	J	Sol. Switch	AA
IC6503	VHiTK10621M-1	J	LPF	AH	Q1704	VSIMX9/////1	J	Sol. Driver	AC
IC6550	RH-IX0264TAZZ	J	TC180G45AF0020	BH	Q1705	VSUMG2/////1	J	Switch	AC
IC6551	RH-IX0278TAZZ	J	HM62V256LT-8	AX	Q1706	VS2SC4738Y/-1	J	Buffer	AA
IC8701	VHiCXX5810T-1	J	1M SRAM	BC	Q3401	VXSP6501///-1	J	Amplifier	AB
TRANSISTORS									
Q702	VSDTC144EE/-1	J	Switch	AA	Q3402	VS2SD1979S/-1	J	Switch	AE
Q703	VS2SC4738Y/-1	J	LED Driver	AA	Q3404	VS2SC4627CD-1	J	Buffer	AB
Q704	VSUN9214///-1	J	Remote Buffer	AB	Q3405	VS2SC4627CD-1	J	Amplifier	AB
Q705	VS2SA1577R/-1	J		AB	Q3701	VXSP4311///-1	J	Switch	AB
Q725	VS2SA1774F/-1	J	Switch	AA	Q4401	VS2SC4738Y/-1	J		AA
Q901	VXSP1B301///-1	J	Regulator	AD	Q4402	VS2SC4738Y/-1	J		AA
Q903	VAFX803/////1	J	BL Power Switch	AG	Q4403	VS2SA1774F/-1	J		AA
Q904	VS2SC4617B/-1	J	Current Detect	AA	Q4404	VS2SC4738Y/-1	J		AA
Q909	VAFX802/////1	J		AG	Q4405	VS2SA1774F/-1	J		AA
Q911	VS2SD1805//1	J	P-CON 4.9V Switch	AF	Q4406	VS2SC4738Y/-1	J		AA
Q912	VS2SB1302S/-1	J	Switch	AD	Q4407	VS2SA1774F/-1	J		AA
Q913	VSUMG5N/////1	J	Switch	AD	Q4412	VS2SA1774F/-1	J		AA
Q914	VXSN4604///-1	J	Switch	AD	Q4701	VS2SC4738Y/-1	J	Buffer	AA
Q921	VAFX803/////1	J	2.8V Burst Up Switch	AG	Q6401	VFSMG12/////1	J	Mute	AD
Q922	VS2SB1302S/-1	J	Switch	AD	Q6403	VS2SA1774F/-1	J	Detector	AA
Q924	VS2SB1302S/-1	J	Switch	AD	Q6404	VSUMD12N///-1	J	Mute Switch	AC
Q932	VS2SB12956/-1	J	Switch	AB	Q6405	VFSMG12/////1	J	Mute	AD
Q933	VS2SB1424Q/-1	J		AD	Q6407	VS2SB12956/-1	J	Switch	AB
Q935	VS2SD1664R/-1	J		AC	Q6408	VSDTC144EE/-1	J	Switch	AA
Q941	VS2SB1121T/-1	J	LCD/CAM Converter Switch	AC	Q6409	VS2SD1819A/-1	J	Regulator	AB
Q942	VSUMT2/////1	J	15V Regulator	AB	Q6410	VSHN1B01FU/-1	J	Switch	AC
Q944	VXSP1213///-1	J	Switch	AB	Q6411	VS2SC4617B/-1	J	Regulator	AA
Q945	VSUMD12N///-1	J	Switch	AC	Q6412	VSDTC144EE/-1	J	Inverter Switch	AA
Q962	VS2SD1805//1	J	Motor 4.6V Switch	AF	Q6453	VSUMX2/////1	J	Buffer	AB
Q963	VS2SB1302S/-1	J	Switch	AD	Q6490	VSUMD12N///-1	J	Inverter Switch	AC
Q965	VSMPL1/////1	J	Drum VS Switch	AE	Q6660	VSUMX2/////1	J		AB
Q966	VSMPL1/////1	J	Capstan VS Switch	AE	DIODES				
Q967	VSDTC144EE/-1	J	Switch	AA	D701	VHDDA221///-1	J	Diode DA221	AB
Q972	VXSN4604///-1	J	Driver	AD	D806	VHDHVU359TR-1	J	Diode	AE
Q973	VAFX803/////1	J	Macha. 4.9V Switch	AG	D807	RH-EX0210TAZZ	J	Zener Diode	AD
Q1401	VS2SB1197KQ-1	J		AC	D808	RH-EX0870CEZZ	J	Zener Diode	AD
Q1402	VSDTC144EE/-1	J		AA	D901	RH-EX0161TAZZ	J	Zener Diode	AD
Q1403	VSDTC144EE/-1	J	Switch	AA	D911	VHDMA2S111/-1	J	Diode MA2S111	AC
Q1404	VS2SB1197KQ-1	J	Switch	AC	D912	VHDSFPB62//2E	J	Diode SFPB62	AD
Q1406	VSUMZ1/////1	J		AB	D913	VHDSFPB62//2E	J	Diode SFPB62	AD
Q1407	VS2SC4738Y/-1	J		AA	D941	VHDDA227///-1	J	Diode DA227	AB
Q1408	VS2SC4738Y/-1	J	Buffer	AA	D942	VHDDA227///-1	J	Diode DA227	AB
Q1409	VS2SA1774F/-1	J		AA	D962	VHDSFPB62//2E	J	Diode SFPB62	AD
Q1410	VSUMZ1/////1	J		AB	D964	VHDSFPB62//2E	J	Diode SFPB62	AD
Q1412	VS2SA1774F/-1	J	Buffer	AA	D971	VHDMA2S111/-1	J	Diode MA2S111	AC
Q1416	VSDTC144EE/-1	J		AA	D1402	VHDUMR11N//1	J	Diode UMR11N	AC
Q1420	VSDTC144EE/-1	J		AA	D1404	VHDUMR11N//1	J	Diode UMR11N	AC
Q1421	VXSP4601///-1	J		AB	D2713	VHDMA729///-1	J	Diode MA729	AD
					D3401	VHDMA704WA/-1	J	Diode MA704WA	AD
					D4401	VHDHVU350B/-1	J	Diode HVU350B	AC
					D4402	VHDHVU350B/-1	J	Diode HVU350B	AC

Ref. No.	Part No.	★	Description	Code	Ref. No.	Part No.	★	Description	Code
DUNTK2635QA01/00									
VCR PWB UNIT (Continued)									
PACKAGED CIRCUITS									
△ CP900	VHICCP2E63/-1	J	Circuit Protector	AD	L942	VP-NM100KR42N	J	Peaking Coil 10μH	AB
△ CP901	VHICCP2E63/-1	J	Circuit Protector	AD	L943	VP-NM100KR42N	J	Peaking Coil 10μH	AB
△ CP902	VHICCP2E63/-1	J	Circuit Protector	AD	L944	VP-NM100KR42N	J	Peaking Coil 10μH	AB
△ CP905	VHICCP2E63/-1	J	Circuit Protector	AD	L945	VP-NM100KR42N	J	Peaking Coil 10μH	AB
△ CP2701	VHICCP2E63/-1	J	Circuit Protector	AD	L961	RCiLP0236TAZZ	J	Coil	AE
TH801	VHHT1103K44-1	J	Thermistor	AD	L962	RCiLP0233TAZZ	J	Coil	AF
X401	RCRSC0091TAZZ	J	Crystal	AM	L963	RCiLP0233TAZZ	J	Coil	AF
X701	RCRSC0032TAZZ	J	Crystal	AG	L964	RCiLP0233TAZZ	J	Coil	AF
X702	RCRSC0106TAZZ	J	Crystal	AK	L971	RCiLP0236TAZZ	J	Coil	AE
X4401	RCRSC0102TAZZ	J	Crystal	AM	L972	RCiLP0233TAZZ	J	Coil	AF
X4403	RCRSC0103TAZZ	J	Crystal	AN	L973	VPBAM2R2M090N	J	Peaking Coil 2.2μH	AC
X6550	RCRSC0107TAZZ	J	Crystal	AL	L1401	VP-NM470K2R0N	J	Peaking Coil 47μH	AB
COIL AND TRANSFORMERS									
CF701	RFILC0061TAZZ	J	Ceramic Filter	AE	L1402	VP-NM101K4R2N	J	Peaking Coil 100μH	AC
FL2401	RFILN0024TAZZ	J	Filter	AF	L1403	VP-NM100KR42N	J	Peaking Coil 10μH	AB
FL3401	RCiLF0334TAZZ	J	Filter	AL	L1701	VP-NM220K1R0N	J	Peaking Coil 22μH	AB
FL3402	RCiLF0334TAZZ	J	Filter	AL	L1704	VP-NM220K1R0N	J	Peaking Coil 22μH	AB
FL3403	RCiLF0335TAZZ	J	Filter	AL	L1705	VP-NM220K1R0N	J	Peaking Coil 22μH	AB
FL3701	RCiLB0040TAZZ	J	Oscillation Coil	AF	L1706	VP-NM220K1R0N	J	Peaking Coil 22μH	AB
FL4401	RCiLF0344TAZZ	J	Filter	AK	L1901	VPAWM100J2R6N	J	Peaking Coil 10μH	AC
FL4404	RCiLF0344TAZZ	J	Filter	AK	L3401	VP-NM4R7MR23N	J	Peaking Coil 4.7μH	AD
FL6550	RCiLZ0280TAZZ	J	Filter	BA	L3402	VP-NM4R7MR23N	J	Peaking Coil 4.7μH	AD
L402	VPABM1R5JR97N	J	Peaking Coil 1.5μH	AC	L3403	VP-NM4R7MR23N	J	Peaking Coil 4.7μH	AD
L403	VPABM4R7J1R7N	J	Peaking Coil 4.7μH	AC	L3405	VP-NM4R7MR23N	J	Peaking Coil 4.7μH	AD
L404	VPABM4R7J1R7N	J	Peaking Coil 4.7μH	AC	L3406	VP-NM4R7MR23N	J	Peaking Coil 4.7μH	AD
L701	VP-NM220K1R0N	J	Peaking Coil 22μH	AB	L3407	VP-NM4R7MR23N	J	Peaking Coil 4.7μH	AD
L711	VP-NM220K1R0N	J	Peaking Coil 22μH	AB	L3410	VP-NM4R7MR23N	J	Peaking Coil 4.7μH	AD
L712	VP-NM220K1R0N	J	Peaking Coil 22μH	AB	L3411	VPABM1R5JR97N	J	Peaking Coil 1.5μH	AC
L814	VPAWM180J3R6N	J	Peaking Coil 18μH	AD	L3412	VP-NM4R7MR23N	J	Peaking Coil 4.7μH	AD
L815	VPAWM100J2R6N	J	Peaking Coil 10μH	AC	L3701	VP-NM470K2R0N	J	Peaking Coil 47μH	AB
L816	VPAWM100J2R6N	J	Peaking Coil 10μH	AC	L3702	VP-NM470K2R0N	J	Peaking Coil 47μH	AB
L817	VP-NM100KR42N	J	Peaking Coil 10μH	AB	L3710	VP-NM220K1R0N	J	Peaking Coil 22μH	AB
L819	VPAWM100J2R6N	J	Peaking Coil 10μH	AC	L4401	VP-NM101K4R2N	J	Peaking Coil 100μH	AC
L820	VPAWM100J2R6N	J	Peaking Coil 10μH	AC	L4402	VP-NM101K4R2N	J	Peaking Coil 100μH	AC
L821	VPAWM100J2R6N	J	Peaking Coil 10μH	AC	L4403	VP-NM101K4R2N	J	Peaking Coil 100μH	AC
L822	VPAWM470J6R4N	J	Peaking Coil 47μH	AC	L4405	RCiLB0045TAZZ	J	Coil	AH
L901	RCiLP0236TAZZ	J	Coil	AE	L4406	VP-NM101K4R2N	J	Peaking Coil 100μH	AC
L902	RCiLP0233TAZZ	J	Coil	AF	L4407	VP-NM101K4R2N	J	Peaking Coil 100μH	AC
L903	RCiLP0226TAZZ	J	Coil	AE	L4410	VP-NM470K2R0N	J	Peaking Coil 47μH	AB
L911	RCiLP0236TAZZ	J	Coil	AE	L6403	VP-WM220KR71N	J	Peaking Coil 22μH	AB
L912	RCiLP0233TAZZ	J	Coil	AF	L6408	VP-NM101K4R2N	J	Peaking Coil 100μH	AC
L913	VPBAM2R2M090N	J	Peaking Coil 2.2μH	AC	L6501	VPBAM101K2R5N	J	Peaking Coil 100μH	AD
L914	VPBAM2R2M090N	J	Peaking Coil 2.2μH	AC	L6502	VPBAM470KR95N	J	Peaking Coil 47μH	AD
L921	RCiLP0236TAZZ	J	Coil	AE	L6550	VP-NM4R7MR23N	J	Peaking Coil 4.7μH	AD
L922	RCiLP0233TAZZ	J	Coil	AF	T901	RTRNZ0106TAZZ	J	Transformer	AG
L923	RCiLP0233TAZZ	J	Coil	AF	CONTROL				
L924	VPBAM2R2M090N	J	Peaking Coil 2.2μH	AC	R3602	RVR-M8023TAZZ	J	PLL Adjust	AC
L925	VPBAM1R0M060N	J	Peaking Coil 1μH	AC	CAPACITORS				
L933	VPBAM2R2M090N	J	Peaking Coil 2.2μH	AC	C401	VCSATA0JJ106M	J	10 6.3V Tantalum	AD
L934	VPBAM2R2M090N	J	Peaking Coil 2.2μH	AC	C402	VCKYCZ1HF103Z	J	0.01 50V Ceramic	AB
L941	RCiLP0236TAZZ	J	Coil	AE	C405	VCSATA0JJ106M	J	10 6.3V Tantalum	AD
					C406	VCKYCZ1HF103Z	J	0.01 50V Ceramic	AB
					C409	VCSATA0JJ106M	J	10 6.3V Tantalum	AD
					C410	VCKYCZ1HF103Z	J	0.01 50V Ceramic	AB
					C411	VCKYCZ1AF104Z	J	0.1 10V Ceramic	AB

Ref. No.	Part No.	★	Description	Code	Ref. No.	Part No.	★	Description	Code
DUNTK2635QA01/00									
VCR PWB UNIT (Continued)									
C412	VCSATA0JJ106M	J 10	6.3V Tantalum	AD	C487	VCKYCZ1HF103Z	J 0.01	50V Ceramic	AB
C413	VCKYCZ1AF104Z	J 0.1	10V Ceramic	AB	C488	VCKYCZ1HF103Z	J 0.01	50V Ceramic	AB
C414	VCSATA0JJ106M	J 10	6.3V Tantalum	AD	C489	VCKYCZ1HF103Z	J 0.01	50V Ceramic	AB
C415	VCKYCZ1HF103Z	J 0.01	50V Ceramic	AB	C490	VCKYCZ1HF103Z	J 0.01	50V Ceramic	AB
C416	VCSATA0JJ106M	J 10	6.3V Tantalum	AD	C491	VCKYCZ1HF103Z	J 0.01	50V Ceramic	AB
C425	VCCCCZ1HH100D	J 10p	50V Ceramic	AB	C492	VCKYCZ1HF103Z	J 0.01	50V Ceramic	AB
C426	VCKYCZ1HB102K	J 1000p	50V Ceramic	AB	C493	VCKYCZ1HF103Z	J 0.01	50V Ceramic	AB
C427	VCCCCZ1HH100D	J 10p	50V Ceramic	AB	C494	VCKYCZ1HF103Z	J 0.01	50V Ceramic	AB
C430	VCKYCZ1HF103Z	J 0.01	50V Ceramic	AB	C495	VCKYCZ1HF103Z	J 0.01	50V Ceramic	AB
C431	VCKYCZ1HF103Z	J 0.01	50V Ceramic	AB	C496	VCKYCZ1HF103Z	J 0.01	50V Ceramic	AB
C432	VCKYCZ1HF103Z	J 0.01	50V Ceramic	AB	C497	VCKYCZ1HF103Z	J 0.01	50V Ceramic	AB
C434	VCKYCZ1HF103Z	J 0.01	50V Ceramic	AB	C499	VCCCCZ1HH200J	J 20p	50V Ceramic	AA
C435	VCKYCZ1HF103Z	J 0.01	50V Ceramic	AB	C701	VCKYCY1AF105Z	J 1	10V Ceramic	AC
C437	VCKYCZ1HF103Z	J 0.01	50V Ceramic	AB	C702	VCKYCZ1HB102K	J 1000p	50V Ceramic	AB
C439	VCKYCZ1HF103Z	J 0.01	50V Ceramic	AB	C705	VCKYCZ1HB102K	J 1000p	50V Ceramic	AB
C440	VCKYCZ1HF103Z	J 0.01	50V Ceramic	AB	C706	VCKYCZ1HB102K	J 1000p	50V Ceramic	AB
C441	VCKYCZ1HF103Z	J 0.01	50V Ceramic	AB	C707	VCKYCZ1HB102K	J 1000p	50V Ceramic	AB
C442	VCKYCZ1HF103Z	J 0.01	50V Ceramic	AB	C708	VCKYCZ1AF104Z	J 0.1	10V Ceramic	AB
C444	VCKYCZ1HF103Z	J 0.01	50V Ceramic	AB	C709	VCKYCZ1HF103Z	J 0.01	50V Ceramic	AB
C445	VCKYCZ1HF103Z	J 0.01	50V Ceramic	AB	C711	VCKYCZ1AF104Z	J 0.1	10V Ceramic	AB
C446	VCKYCZ1HF103Z	J 0.01	50V Ceramic	AB	C712	VCKYCZ1AF104Z	J 0.1	10V Ceramic	AB
C447	VCKYCZ1HF103Z	J 0.01	50V Ceramic	AB	C713	VCKYCZ1HF103Z	J 0.01	50V Ceramic	AB
C448	VCKYCZ1HF103Z	J 0.01	50V Ceramic	AB	C714	VCSATA0JJ106M	J 10	6.3V Tantalum	AD
C449	VCKYCZ1HF103Z	J 0.01	50V Ceramic	AB	C715	VCKYCZ1AF104Z	J 0.1	10V Ceramic	AB
C450	VCKYCZ1HF103Z	J 0.01	50V Ceramic	AB	C716	VCKYCZ1AF104Z	J 0.1	10V Ceramic	AB
C451	VCSATA0JJ106M	J 10	6.3V Tantalum	AD	C717	VCCCCZ1HH120J	J 12p	50V Ceramic	AB
C452	VCKYCZ1CB103K	J 0.01	16V Ceramic	AB	C718	VCCCCZ1HH120J	J 12p	50V Ceramic	AB
C453	VCKYCZ1CB103K	J 0.01	16V Ceramic	AB	C751	VCKYCY1AF105Z	J 1	10V Ceramic	AC
C454	VCSATA1AJ106M	J 10	10V Tantalum	AC	C752	VCKYCY1AF105Z	J 1	10V Ceramic	AC
C455	VCKYCZ1CB103K	J 0.01	16V Ceramic	AB	C753	VCCCCZ1HH5R0C	J 5p	50V Ceramic	AC
C456	VCKYCZ1HF103Z	J 0.01	50V Ceramic	AB	C754	VCCCCZ1HH5R0C	J 5p	50V Ceramic	AC
C458	VCCCCZ1HH150J	J 15p	50V Ceramic	AB	C755	VCKYCZ1AF104Z	J 0.1	10V Ceramic	AB
C462	VCKYCZ1AF104Z	J 0.1	10V Ceramic	AB	C756	VCSATA0JJ106M	J 10	6.3V Tantalum	AD
C463	VCKYCZ1AF104Z	J 0.1	10V Ceramic	AB	C757	VCKYCZ1AF104Z	J 0.1	10V Ceramic	AB
C464	VCKYCZ1AF104Z	J 0.1	10V Ceramic	AB	C758	VCSATA0JJ106M	J 10	6.3V Tantalum	AD
C465	VCKYCZ1AF104Z	J 0.1	10V Ceramic	AB	C759	VCKYTV1EB104K	J 0.1	25V Ceramic	AB
C466	VCKYCZ1AF104Z	J 0.1	10V Ceramic	AB	C760	VCKYCY1AF105Z	J 1	10V Ceramic	AC
C467	VCKYCZ1AF104Z	J 0.1	10V Ceramic	AB	C761	VCKYTV1HB473K	J 0.047	50V Ceramic	AA
C468	VCKYCZ1AF104Z	J 0.1	10V Ceramic	AB	C762	VCKYTV1EB104K	J 0.1	25V Ceramic	AB
C469	VCKYCZ1AF104Z	J 0.1	10V Ceramic	AB	C763	VCKYCZ1HB102K	J 1000p	50V Ceramic	AB
C470	VCKYCZ1AF104Z	J 0.1	10V Ceramic	AB	C764	VCKYCZ1EB682K	J 6800p	25V Ceramic	AB
C471	VCKYCZ1AF104Z	J 0.1	10V Ceramic	AB	C765	VCKYCZ1AF104Z	J 0.1	10V Ceramic	AB
C472	VCKYCZ1HF103Z	J 0.01	50V Ceramic	AB	C767	VCKYCZ1HB102K	J 1000p	50V Ceramic	AB
C473	VCKYCZ1HF103Z	J 0.01	50V Ceramic	AB	C768	VCKYCZ1HB102K	J 1000p	50V Ceramic	AB
C474	VCKYCZ1HF103Z	J 0.01	50V Ceramic	AB	C769	VCKYCZ1HB102K	J 1000p	50V Ceramic	AB
C479	VCSATA0JJ106M	J 10	6.3V Tantalum	AD	C770	VCKYCZ1HB102K	J 1000p	50V Ceramic	AB
C480	VCKYCZ1HF103Z	J 0.01	50V Ceramic	AB	C800	VCKYCZ1AF104Z	J 0.1	10V Ceramic	AB
C481	VCKYCZ1HF103Z	J 0.01	50V Ceramic	AB	C801	VCCCCY1EH561J	J 560p	25V Ceramic	AA
C482	VCKYCZ1HF103Z	J 0.01	50V Ceramic	AB	C802	VCKYCZ1HF103Z	J 0.01	50V Ceramic	AB
C483	VCKYCZ1HF103Z	J 0.01	50V Ceramic	AB	C804	VCKYCZ1HF103Z	J 0.01	50V Ceramic	AB
C484	VCKYCZ1HF103Z	J 0.01	50V Ceramic	AB	C805	VCKYCZ1HF103Z	J 0.01	50V Ceramic	AB
C485	VCKYCZ1HF103Z	J 0.01	50V Ceramic	AB	C806	VCKYCZ1HF103Z	J 0.01	50V Ceramic	AB
C486	VCKYCZ1HF103Z	J 0.01	50V Ceramic	AB	C807	VCCCCZ1HH560J	J 56p	50V Ceramic	AB
					C808	VCSATA1AJ106M	J 10	10V Tantalum	AC
					C809	VCKYCZ1HF103Z	J 0.01	50V Ceramic	AB
					C810	VCCCCZ1HH220J	J 22p	50V Ceramic	AB

Ref. No.	Part No.	★	Description	Code	Ref. No.	Part No.	★	Description	Code
DUNTK2635QA01/00									
VCR PWB UNIT (Continued)									
C811	VCCCCZ1HH560J	J	56p 50V Ceramic	AB	C907	VCKYCZ1AF104Z	J	0.1 10V Ceramic	AB
C812	VCSATA0JJ106M	J	10 6.3V Tantalum	AD	C908	VCKYCY1CB104K	J	0.1 16V Ceramic	AB
C814	VCKYCZ1HF103Z	J	0.01 50V Ceramic	AB	C909	RC-CZ0017TAZZ	J	2.2 16V Ceramic	AE
C815	VCKYCZ1HF103Z	J	0.01 50V Ceramic	AB	C911	RC-KZ0042TAZZ	J	4.7 6.3V Ceramic	AE
C816	VCKYCZ1AF104Z	J	0.1 10V Ceramic	AB	C912	RC-KZ0042TAZZ	J	4.7 6.3V Ceramic	AE
C817	VCKYCZ1HF103Z	J	0.01 50V Ceramic	AB	C913	VCKYTV1AB105K	J	1 10V Ceramic	AD
C818	VCKYCZ1AF104Z	J	0.1 10V Ceramic	AB	C914	VCKYTV1AB105K	J	1 10V Ceramic	AD
C819	VCKYCZ1HF103Z	J	0.01 50V Ceramic	AB	C915	VCKYTV1AB105K	J	1 10V Ceramic	AD
C820	VCSATA0JJ106M	J	10 6.3V Tantalum	AD	C921	RC-CZ0019TAZZ	J	2.2 10V Ceramic	AF
C822	VCKYCZ1HF103Z	J	0.01 50V Ceramic	AB	C922	RC-KZ0042TAZZ	J	4.7 6.3V Ceramic	AE
C823	VCSATE1AJ226M	J	22 10V Tantalum	AD	C923	RC-KZ0042TAZZ	J	4.7 6.3V Ceramic	AE
C824	VCKYCZ1HF103Z	J	0.01 50V Ceramic	AB	C924	VCKYTQ1CB105K	J	1 16V Ceramic	AC
C825	VCKYCZ1HF103Z	J	0.01 50V Ceramic	AB	C925	VCKYTQ1CB105K	J	1 16V Ceramic	AC
C826	VCKYCZ1HF103Z	J	0.01 50V Ceramic	AB	C926	VCSNCE1AC106M	J	10 10V Sp. Polymer	AF
C827	VCSATE1CJ106M	J	10 16V Tantalum	AD	C935	VCKYCY1AF105Z	J	1 10V Ceramic	AC
C828	VCKYCZ1HF103Z	J	0.01 50V Ceramic	AB	C936	VCSATA1AJ106M	J	10 10V Tantalum	AC
C829	VCSATC1AJ476M	J	47 10V Tantalum	AE	C937	VCKYTV1AB105K	J	1 10V Ceramic	AD
C830	VCKYCZ1HF103Z	J	0.01 50V Ceramic	AB	C941	VCKYTQ0JB335M	J	3.3 6.3V Ceramic	AE
C831	VCKYCZ1HF103Z	J	0.01 50V Ceramic	AB	C942	RC-KZ0046TAZZ	J	4.7 3.5V Ceramic	AD
C832	VCKYCZ1HF103Z	J	0.01 50V Ceramic	AB	C943	RC-CZ0019TAZZ	J	2.2 10V Ceramic	AF
C836	VCKYCZ1HF103Z	J	0.01 50V Ceramic	AB	C944	RC-CZ0019TAZZ	J	2.2 10V Ceramic	AF
C839	VCKYCZ1HF103Z	J	0.01 50V Ceramic	AB	C945	RC-KZ0046TAZZ	J	4.7 3.5V Ceramic	AD
C840	VCKYTQ1CB105K	J	1 16V Ceramic	AC	C946	VCKYTV1EB104K	J	0.1 25V Ceramic	AB
C841	VCKYTQ1CB105K	J	1 16V Ceramic	AC	C947	VCKYTV1CF105Z	J	1 16V Ceramic	AB
C842	VCKYTQ1CB105K	J	1 16V Ceramic	AC	C948	VCKYTV1CF105Z	J	1 16V Ceramic	AB
C843	VCSAPD1AJ225M	J	2.2 10V Tantalum	AC	C949	VCKYTV1EB104K	J	0.1 25V Ceramic	AB
C844	VCSATC1CJ226M	J	22 16V Tantalum	AF	C950	VCKYCZ1EF223Z	J	0.022 25V Ceramic	AB
C845	VCKYCZ1HF103Z	J	0.01 50V Ceramic	AB	C964	RC-CZ0019TAZZ	J	2.2 10V Ceramic	AF
C846	VCSATC1CJ226M	J	22 16V Tantalum	AF	C965	RC-KZ0042TAZZ	J	4.7 6.3V Ceramic	AE
C847	VCKYCZ1HF103Z	J	0.01 50V Ceramic	AB	C966	VCSNCE1AC106M	J	10 10V Sp. Polymer	AF
C848	VCSATE1VJ335M	J	3.3 35V Tantalum	AD	C968	RC-KZ0042TAZZ	J	4.7 6.3V Ceramic	AE
C849	VCKYTQ1CB105K	J	1 16V Ceramic	AC	C969	RC-KZ0042TAZZ	J	4.7 6.3V Ceramic	AE
C850	VCSATE1DJ475M	J	4.7 20V Tantalum	AD	C973	VCKYTV1EB104K	J	0.1 25V Ceramic	AB
C851	VCKYCZ1HF103Z	J	0.01 50V Ceramic	AB	C974	VCKYTV1EB104K	J	0.1 25V Ceramic	AB
C853	VCKYCZ1HF103Z	J	0.01 50V Ceramic	AB	C976	VCKYCZ1HB471K	J	470p 50V Ceramic	AB
C854	VCKYCZ1HF103Z	J	0.01 50V Ceramic	AB	C977	VCKYCZ1EB472K	J	4700p 25V Ceramic	AB
C855	VCKYCZ1HF103Z	J	0.01 50V Ceramic	AB	C978	VCKYCZ1CB103K	J	0.01 16V Ceramic	AB
C856	VCKYCZ1HF103Z	J	0.01 50V Ceramic	AB	C979	VCKYCY1AF105Z	J	1 10V Ceramic	AC
C857	VCKYCZ1HF103Z	J	0.01 50V Ceramic	AB	C980	RC-CZ0019TAZZ	J	2.2 10V Ceramic	AF
C858	VCCCCZ1HH470J	J	47p 50V Ceramic	AB	C981	VCSNCE1AC106M	J	10 10V Sp. Polymer	AF
C859	VCCCCZ1HH470J	J	47p 50V Ceramic	AB	C982	RC-CZ0019TAZZ	J	2.2 10V Ceramic	AF
C860	VCCCCZ1HH470J	J	47p 50V Ceramic	AB	C983	VCKYTV1EB104K	J	0.1 25V Ceramic	AB
C861	VCKYCZ1HB471K	J	470p 50V Ceramic	AB	C1401	VCKYCY1CF474Z	J	0.47 16V Ceramic	AB
C862	VCKYCZ1HB471K	J	470p 50V Ceramic	AB	C1402	VCKYCZ1HF103Z	J	0.01 50V Ceramic	AB
C863	VCCCCZ1HH221J	J	220p 50V Ceramic	AB	C1403	VCSATA0JJ106M	J	10 6.3V Tantalum	AD
C869	VCKYCZ1HB102K	J	1000p 50V Ceramic	AB	C1404	VCKYCY1CF474Z	J	0.47 16V Ceramic	AB
C885	VCKYCZ1HB102K	J	1000p 50V Ceramic	AB	C1405	VCKYCY1CF474Z	J	0.47 16V Ceramic	AB
C900	VCSNCA1AC475M	J	4.7 10V Sp. Polymer	AG	C1406	VCKYCZ1HF103Z	J	0.01 50V Ceramic	AB
C901	VCKYCZ1CB103K	J	0.01 16V Ceramic	AB	C1407	VCKYCZ1HF103Z	J	0.01 50V Ceramic	AB
C903	RC-CZ0019TAZZ	J	2.2 10V Ceramic	AF	C1408	VCKYCZ1HF103Z	J	0.01 50V Ceramic	AB
C904	RC-KZ0026TAZZ	J	6.8 16V Ceramic	AF	C1409	VCKYCZ1HF103Z	J	0.01 50V Ceramic	AB
C905	VCKYCZ1CB103K	J	0.01 16V Ceramic	AB	C1410	VCKYCZ1AF104Z	J	0.1 10V Ceramic	AB
C906	VCKYCZ1AF104Z	J	0.1 10V Ceramic	AB	C1411	VCSATA0JJ106M	J	10 6.3V Tantalum	AD
					C1412	VCSATA0JJ106M	J	10 6.3V Tantalum	AD
					C1413	VCKYCZ1HF103Z	J	0.01 50V Ceramic	AB
					C1416	VCSATA1AJ475M	J	4.7 10V Tantalum	AC

Ref. No.	Part No.	★	Description	Code	Ref. No.	Part No.	★	Description	Code
DUNTK2635QA01/00									
VCR PWB UNIT (Continued)									
C1417	VCSATC0JJ107M	J 100	6.3V Tantalum	AG	C1759	VCKYCZ1AF104Z	J 0.1	10V Ceramic	AB
C1418	VCSATA1AJ475M	J 4.7	10V Tantalum	AC	C1760	VCKYCY1AF105Z	J 1	10V Ceramic	AC
C1419	VCSATA1AJ475M	J 4.7	10V Tantalum	AC	C1762	VCKYCY1AF105Z	J 1	10V Ceramic	AC
C1420	VCSATC0JJ107M	J 100	6.3V Tantalum	AG	C1763	VCKYCZ1AF104Z	J 0.1	10V Ceramic	AB
C1421	VCSATC1AJ476M	J 47	10V Tantalum	AE	C1769	VCKYCZ1CB103K	J 0.01	16V Ceramic	AB
C1422	VCKYCZ1HF103Z	J 0.01	50V Ceramic	AB	C1770	VCKYCZ1AF104Z	J 0.1	10V Ceramic	AB
C1423	VCKYCY1CF474Z	J 0.47	16V Ceramic	AB	C1771	VCKYCZ1CB103K	J 0.01	16V Ceramic	AB
C1424	VCKYCY1CF474Z	J 0.47	16V Ceramic	AB	C1772	VCKYCZ1AF104Z	J 0.1	10V Ceramic	AB
C1425	VCSATC1AJ476M	J 47	10V Tantalum	AE	C1774	VCKYCY1CF154Z	J 0.15	16V Ceramic	AB
C1426	VCKYCZ1HF103Z	J 0.01	50V Ceramic	AB	C1775	VCKYCY1CF154Z	J 0.15	16V Ceramic	AB
C1427	VCKYCY1AF105Z	J 1	10V Ceramic	AC	C1778	VCKYQ0JB335M	J 3.3	6.3V Ceramic	AE
C1428	VCKYCY1CF474Z	J 0.47	16V Ceramic	AB	C1779	VCKYQ0JB335M	J 3.3	6.3V Ceramic	AE
C1429	VCKYCY1CF474Z	J 0.47	16V Ceramic	AB	C1782	VCKYQ0JB335M	J 3.3	6.3V Ceramic	AE
C1430	VCSATC1AJ476M	J 47	10V Tantalum	AE	C1783	VCKYQ0JB335M	J 3.3	6.3V Ceramic	AE
C1437	VCKYCZ1HF103Z	J 0.01	50V Ceramic	AB	C1784	VCCCCZ1HH470J	J 47p	50V Ceramic	AB
C1439	VCKYCZ1AF104Z	J 0.1	10V Ceramic	AB	C1785	VCSATD0JJ227M	J 220	6.3V Tantalum	AH
C1440	VCKYCZ1AF104Z	J 0.1	10V Ceramic	AB	C1791	VCKYCY1HB103K	J 0.01	50V Ceramic	AA
C1441	VCKYCZ1HF103Z	J 0.01	50V Ceramic	AB	C1792	VCKYCY1HB103K	J 0.01	50V Ceramic	AA
C1442	VCSATA0JJ106M	J 10	6.3V Tantalum	AD	C1901	VCCCCY1HH221J	J 220p	50V Ceramic	AA
C1443	VCSATC1AJ476M	J 47	10V Tantalum	AE	C1902	VCCCCY1HH221J	J 220p	50V Ceramic	AA
C1447	VCKYCZ1HF103Z	J 0.01	50V Ceramic	AB	C1903	VCKYCY1HB471K	J 470p	50V Ceramic	AA
C1448	VCKYCZ1HF103Z	J 0.01	50V Ceramic	AB	C1904	VCKYTV1EB104K	J 0.1	25V Ceramic	AB
C1450	VCKYCZ1CB822K	J 8200p	16V Ceramic	AB	C1905	VCKYTV1CB224K	J 0.22	16V Ceramic	AB
C1451	VCKYCZ1HB821K	J 820p	50V Ceramic	AC	C1906	VCKYTV1CB224K	J 0.22	16V Ceramic	AB
C1452	VCSATA1CJ225M	J 2.2	16V Tantalum	AC	C1907	VCKYTV1CB224K	J 0.22	16V Ceramic	AB
C1453	VCKYCZ1HF103Z	J 0.01	50V Ceramic	AB	C1908	VCKYTV1HB103K	J 0.01	50V Ceramic	AA
C1701	VCKYCZ1HF103Z	J 0.01	50V Ceramic	AB	C1909	VCKYCY1HB182K	J 1800p	50V Ceramic	AA
C1702	VCKYCZ1HB102K	J 1000p	50V Ceramic	AB	C1910	VCKYTV1EB104K	J 0.1	25V Ceramic	AB
C1703	VCKYCZ1HB102K	J 1000p	50V Ceramic	AB	C1912	VCKYTV1AB105K	J 1	10V Ceramic	AD
C1704	VCKYTV1EB104K	J 0.1	25V Ceramic	AB	C1913	VCKYCY1CF104Z	J 0.1	16V Ceramic	AA
C1705	VCKYTV1EB104K	J 0.1	25V Ceramic	AB	C1914	VCKYCY1CF104Z	J 0.1	16V Ceramic	AA
C1706	VCSATA1AJ106M	J 10	10V Tantalum	AC	C1915	VCKYTV1EB104K	J 0.1	25V Ceramic	AB
C1707	VCSATA1AJ106M	J 10	10V Tantalum	AC	C1916	VCKYTV1CB224K	J 0.22	16V Ceramic	AB
C1708	VCSATA1AJ106M	J 10	10V Tantalum	AC	C1917	VCKYTV1AB105K	J 1	10V Ceramic	AD
C1709	VCKYCZ1AF104Z	J 0.1	10V Ceramic	AB	C1918	VCKYTV1CB224K	J 0.22	16V Ceramic	AB
C1710	VCKYCZ1AF104Z	J 0.1	10V Ceramic	AB	C1919	VCKYTV1EB104K	J 0.1	25V Ceramic	AB
C1711	VCKYTV1EB823K	J 0.082	25V Ceramic	AC	C1920	VCKYCY1CB473K	J 0.047	16V Ceramic	AA
C1712	VCKYCY1AF105Z	J 1	10V Ceramic	AC	C1924	VCKYCY1CB104K	J 0.1	16V Ceramic	AB
C1713	VCKYCY1CB473K	J 0.047	16V Ceramic	AA	C1926	VCKYCZ1AF104Z	J 0.1	10V Ceramic	AB
C1714	VCKYCZ1EB472K	J 4700p	25V Ceramic	AB	C1927	VCKYCZ1HB102K	J 1000p	50V Ceramic	AB
C1716	VCSAPD1CJ105M	J 1	16V Tantalum	AC	C1930	VCKYCZ1HB102K	J 1000p	50V Ceramic	AB
C1717	VCKYCZ1EB682K	J 6800p	25V Ceramic	AB	C1931	VCKYCZ1AF104Z	J 0.1	10V Ceramic	AB
C1718	VCKYCZ1EB682K	J 6800p	25V Ceramic	AB	C1932	VCKYCZ1HB102K	J 1000p	50V Ceramic	AB
C1719	VCKYCZ1EB682K	J 6800p	25V Ceramic	AB	C1933	VCKYCZ1EB472K	J 4700p	25V Ceramic	AB
C1723	VCKYCY1AF105Z	J 1	10V Ceramic	AC	C1934	VCKYCY1CB104K	J 0.1	16V Ceramic	AB
C1724	VCKYCY1AF105Z	J 1	10V Ceramic	AC	C2701	VCKYCY1CF104Z	J 0.1	16V Ceramic	AA
C1725	VCKYCY1AF105Z	J 1	10V Ceramic	AC	C2704	VCKYCY1CF104Z	J 0.1	16V Ceramic	AA
C1727	VCKYCY1CF154Z	J 0.15	16V Ceramic	AB	C2705	VCSATA0JJ106M	J 10	6.3V Tantalum	AD
C1729	VCKYCZ1AF104Z	J 0.1	10V Ceramic	AB	C2706	VCKYCZ1HF103Z	J 0.01	50V Ceramic	AB
C1732	VCKYCZ1CB103K	J 0.01	16V Ceramic	AB	C2708	VCKYTV1CB224K	J 0.22	16V Ceramic	AB
C1735	VCKYCZ1CB103K	J 0.01	16V Ceramic	AB	C2713	VCKYCY1CF104Z	J 0.1	16V Ceramic	AA
C1740	VCKYTV1CF105Z	J 1	16V Ceramic	AB	C2730	VCKYCZ1HB102K	J 1000p	50V Ceramic	AB
C1741	VCSATA1AJ106M	J 10	10V Tantalum	AC	C3401	VCCCCZ1HH120J	J 12p	50V Ceramic	AB
					C3406	VCKYCZ1HF103Z	J 0.01	50V Ceramic	AB
					C3407	VCKYCZ1AF104Z	J 0.1	10V Ceramic	AB
					C3408	VCKYCZ1HF103Z	J 0.01	50V Ceramic	AB

Ref. No.	Part No.	★	Description	Code	Ref. No.	Part No.	★	Description	Code
DUNTK2635QA01/00									
VCR PWB UNIT (Continued)									
C3409	VCKYCZ1AF104Z	J 0.1	10V Ceramic	AB	C3476	VCSATA1AJ106M	J 10	10V Tantalum	AC
C3410	VCKYCZ1HF103Z	J 0.01	50V Ceramic	AB	C3477	VCKYCZ1AF104Z	J 0.1	10V Ceramic	AB
C3411	VCSATA0JJ106M	J 10	6.3V Tantalum	AD	C3478	VCKYCZ1AF104Z	J 0.1	10V Ceramic	AB
C3412	VCKYTV1CF334Z	J 0.33	16V Ceramic	AB	C3479	VCKYCZ1HF103Z	J 0.01	50V Ceramic	AB
C3414	VCKYCZ1HF103Z	J 0.01	50V Ceramic	AB	C3480	VCKYCZ1HF103Z	J 0.01	50V Ceramic	AB
C3415	VCSATA0JJ106M	J 10	6.3V Tantalum	AD	C3481	VCCCCZ1HH120J	J 12p	50V Ceramic	AB
C3418	VCKYCZ1HF103Z	J 0.01	50V Ceramic	AB	C3482	VCKYCZ1HF103Z	J 0.01	50V Ceramic	AB
C3419	VCKYCZ1AF104Z	J 0.1	10V Ceramic	AB	C3483	VCKYCZ1HF103Z	J 0.01	50V Ceramic	AB
C3421	VCSATA0JJ106M	J 10	6.3V Tantalum	AD	C3484	VCKYCZ1HF103Z	J 0.01	50V Ceramic	AB
C3422	VCKYCZ1HF103Z	J 0.01	50V Ceramic	AB	C3485	VCKYCZ1AF104Z	J 0.1	10V Ceramic	AB
C3423	VCKYCZ1HF103Z	J 0.01	50V Ceramic	AB	C3486	VCCCCZ1HH150J	J 15p	50V Ceramic	AB
C3424	VCKYCZ1HF103Z	J 0.01	50V Ceramic	AB	C3487	VCKYCZ1HF103Z	J 0.01	50V Ceramic	AB
C3425	VCKYCZ1AF104Z	J 0.1	10V Ceramic	AB	C3488	VCKYCZ1CB822K	J 8200p	16V Ceramic	AB
C3426	VCKYCZ1HF103Z	J 0.01	50V Ceramic	AB	C3490	VCCCCZ1HH100D	J 10p	50V Ceramic	AB
C3429	VCKYCZ1CB223K	J 0.022	16V Ceramic	AC	C3491	VCKYCZ1HF103Z	J 0.01	50V Ceramic	AB
C3430	VCKYCZ1HF103Z	J 0.01	50V Ceramic	AB	C3495	VCCCCZ1HH220J	J 22p	50V Ceramic	AB
C3431	VCKYCZ1AF104Z	J 0.1	10V Ceramic	AB	C3496	VCKYCZ1AF104Z	J 0.1	10V Ceramic	AB
C3432	VCKYCZ1HF103Z	J 0.01	50V Ceramic	AB	C3497	VCKYCZ1AF104Z	J 0.1	10V Ceramic	AB
C3433	VCKYCZ1HF103Z	J 0.01	50V Ceramic	AB	C3498	VCKYCZ1HF103Z	J 0.01	50V Ceramic	AB
C3436	VCKYCZ1HF103Z	J 0.01	50V Ceramic	AB	C3500	VCKYCZ1HF103Z	J 0.01	50V Ceramic	AB
C3437	VCSATA1AJ106M	J 10	10V Tantalum	AC	C3701	VCSATA0JJ106M	J 10	6.3V Tantalum	AD
C3438	VCKYCZ1CB223K	J 0.022	16V Ceramic	AC	C3702	VCKYCZ1AF104Z	J 0.1	10V Ceramic	AB
C3440	VCSAPD1AJ225M	J 2.2	10V Tantalum	AC	C3703	VCKYCZ1AF104Z	J 0.1	10V Ceramic	AB
C3441	VCKYTV1CF225Z	J 2.2	16V Ceramic	AC	C3704	VCKYCZ1AF104Z	J 0.1	10V Ceramic	AB
C3442	VCKYCZ1HF103Z	J 0.01	50V Ceramic	AB	C3706	VCSATA1AJ106M	J 10	10V Tantalum	AC
C3443	VCSATA1AJ106M	J 10	10V Tantalum	AC	C3721	VCKYCZ1AF104Z	J 0.1	10V Ceramic	AB
C3445	VCKYCZ1HF103Z	J 0.01	50V Ceramic	AB	C3722	VCKYCZ1HB102K	J 1000p	50V Ceramic	AB
C3446	VCSATA1AJ106M	J 10	10V Tantalum	AC	C3723	VCKYCZ1AF104Z	J 0.1	10V Ceramic	AB
C3447	VCKYCZ1AF104Z	J 0.1	10V Ceramic	AB	C3724	VCKYCZ1AF104Z	J 0.1	10V Ceramic	AB
C3448	VCKYCZ1AF104Z	J 0.1	10V Ceramic	AB	C3750	VCKYCZ1AF104Z	J 0.1	10V Ceramic	AB
C3450	VCCCCZ1HH680J	J 68p	50V Ceramic	AB	C3751	VCKYCZ1AF104Z	J 0.1	10V Ceramic	AB
C3451	VCKYCZ1AF104Z	J 0.1	10V Ceramic	AB	C3754	VCSATA1AJ475M	J 4.7	10V Tantalum	AC
C3452	VCKYCZ1AF104Z	J 0.1	10V Ceramic	AB	C3756	VCKYCY1AF105Z	J 1	10V Ceramic	AC
C3453	VCKYCZ1HF103Z	J 0.01	50V Ceramic	AB	C3799	VCKYCZ1HB102K	J 1000p	50V Ceramic	AB
C3455	VCKYCZ1HF103Z	J 0.01	50V Ceramic	AB	C4401	VCKYCZ1AF104Z	J 0.1	10V Ceramic	AB
C3456	VCKYCZ1AF104Z	J 0.1	10V Ceramic	AB	C4402	VCSATA0JJ106M	J 10	6.3V Tantalum	AD
C3457	VCKYCZ1AF104Z	J 0.1	10V Ceramic	AB	C4403	VCKYCZ1AF104Z	J 0.1	10V Ceramic	AB
C3458	VCKYCZ1AF104Z	J 0.1	10V Ceramic	AB	C4404	VCKYCY1CF474Z	J 0.47	16V Ceramic	AB
C3460	VCKYCZ1HF103Z	J 0.01	50V Ceramic	AB	C4405	VCKYCZ1AF104Z	J 0.1	10V Ceramic	AB
C3461	VCKYCZ1AF104Z	J 0.1	10V Ceramic	AB	C4406	VCKYCZ1AF104Z	J 0.1	10V Ceramic	AB
C3462	VCKYCZ1AF104Z	J 0.1	10V Ceramic	AB	C4407	VCKYCZ1HB152K	J 1500p	50V Ceramic	AB
C3463	VCKYCZ1AF104Z	J 0.1	10V Ceramic	AB	C4408	VCSATA1AJ106M	J 10	10V Tantalum	AC
C3464	VCKYCZ1HF103Z	J 0.01	50V Ceramic	AB	C4409	VCKYCZ1AF104Z	J 0.1	10V Ceramic	AB
C3465	VCKYCZ1HF103Z	J 0.01	50V Ceramic	AB	C4411	VCKYCZ1AF104Z	J 0.1	10V Ceramic	AB
C3466	VCCCCZ1HH560J	J 56p	50V Ceramic	AB	C4412	VCKYCZ1AF104Z	J 0.1	10V Ceramic	AB
C3467	VCKYCZ1HF103Z	J 0.01	50V Ceramic	AB	C4413	VCSATA1AJ106M	J 10	10V Tantalum	AC
C3468	VCSATA1AJ106M	J 10	10V Tantalum	AC	C4414	VCKYCZ1AF104Z	J 0.1	10V Ceramic	AB
C3469	VCKYCZ1HF103Z	J 0.01	50V Ceramic	AB	C4415	VCKYCZ1AF104Z	J 0.1	10V Ceramic	AB
C3470	VCKYCZ1HF103Z	J 0.01	50V Ceramic	AB	C4416	VCSATA1AJ106M	J 10	10V Tantalum	AC
C3472	VCKYCZ1HF103Z	J 0.01	50V Ceramic	AB	C4417	VCKYCZ1AF104Z	J 0.1	10V Ceramic	AB
C3473	VCKYCZ1HB102K	J 1000p	50V Ceramic	AB	C4418	VCKYCZ1AF104Z	J 0.1	10V Ceramic	AB
C3474	VCKYCZ1HB102K	J 1000p	50V Ceramic	AB	C4419	VCKYCY1AF105Z	J 1	10V Ceramic	AC
C3475	VCKYCZ1HF103Z	J 0.01	50V Ceramic	AB	C4420	VCSATA1AJ106M	J 10	10V Tantalum	AC
					C4421	VCKYCZ1AF104Z	J 0.1	10V Ceramic	AB
					C4422	VCKYCZ1AF104Z	J 0.1	10V Ceramic	AB
					C4424	VCKYCZ1AF104Z	J 0.1	10V Ceramic	AB

Ref. No.	Part No.	★	Description	Code	Ref. No.	Part No.	★	Description	Code
DUNTK2635QA01/00									
VCR PWB UNIT (Continued)									
C4425	VCKYCZ1AF104Z	J 0.1	10V Ceramic	AB	C6499	VCSATC1AJ476M	J 47	10V Tantalum	AE
C4426	VCKYCZ1CB103K	J 0.01	16V Ceramic	AB	C6501	VCSATA0JJ106M	J 10	6.3V Tantalum	AD
C4427	VCKYCZ1HB102K	J 1000p	50V Ceramic	AB	C6502	VCKYCZ1HF103Z	J 0.01	50V Ceramic	AB
C4428	VCSATA1AJ106M	J 10	10V Tantalum	AC	C6503	VCSATA0JJ106M	J 10	6.3V Tantalum	AD
C4429	VCKYCZ1AF104Z	J 0.1	10V Ceramic	AB	C6504	VCKYCZ1HF103Z	J 0.01	50V Ceramic	AB
C4430	VCSATA1AJ106M	J 10	10V Tantalum	AC	C6505	VCKYCZ1HB152K	J 1500p	50V Ceramic	AB
C4431	VCKYCZ1AF104Z	J 0.1	10V Ceramic	AB	C6506	VCKYCZ1HB152K	J 1500p	50V Ceramic	AB
C4432	VCKYCZ1AF104Z	J 0.1	10V Ceramic	AB	C6507	VCKYCZ1AF104Z	J 0.1	10V Ceramic	AB
C4433	VCSATA0JJ106M	J 10	6.3V Tantalum	AD	C6508	VCSATA0JJ106M	J 10	6.3V Tantalum	AD
C4434	VCKYCZ1AF104Z	J 0.1	10V Ceramic	AB	C6509	VCKYCZ1HF103Z	J 0.01	50V Ceramic	AB
C4436	VCSATE1AJ336M	J 33	10V Tantalum	AG	C6518	VCSATA0GJ226M	J 22	4V Tantalum	AD
C4437	VCKYCZ1HF103Z	J 0.01	50V Ceramic	AB	C6519	VCSATA0GJ226M	J 22	4V Tantalum	AD
C4439	VCKYCZ1AF104Z	J 0.1	10V Ceramic	AB	C6520	VCSATA0GJ226M	J 22	4V Tantalum	AD
C4440	VCKYCZ1AF104Z	J 0.1	10V Ceramic	AB	C6521	VCSATA0JJ106M	J 10	6.3V Tantalum	AD
C4492	VCCCCZ1HH6R0D	J 6p	50V Ceramic	AA	C6534	VCKYCY1AF105Z	J 1	10V Ceramic	AC
C4493	VCCCCZ1HH6R0D	J 6p	50V Ceramic	AA	C6535	VCKYCY1AF105Z	J 1	10V Ceramic	AC
C4494	VCKYCZ1HF103Z	J 0.01	50V Ceramic	AB	C6540	VCKYCZ1HB471K	J 470p	50V Ceramic	AB
C4495	VCKYCZ1HF103Z	J 0.01	50V Ceramic	AB	C6541	VCKYCZ1HB471K	J 470p	50V Ceramic	AB
C4496	VCSATA0JJ106M	J 10	6.3V Tantalum	AD	C6550	VCSATA0JJ106M	J 10	6.3V Tantalum	AD
C4499	VCKYCZ1HF103Z	J 0.01	50V Ceramic	AB	C6551	VCKYTV1CF225Z	J 2.2	16V Ceramic	AC
C4512	VCKYCZ1HF103Z	J 0.01	50V Ceramic	AB	C6552	VCKYCZ1HF103Z	J 0.01	50V Ceramic	AB
C4513	VCKYCZ1HF103Z	J 0.01	50V Ceramic	AB	C6553	VCSATA1AJ475M	J 4.7	10V Tantalum	AC
C4515	VCSATA0JJ106M	J 10	6.3V Tantalum	AD	C6554	VCKYTV1HB473K	J 0.047	50V Ceramic	AA
C6401	VCSATE1VJ335M	J 3.3	35V Tantalum	AD	C6555	VCSATA0JJ106M	J 10	6.3V Tantalum	AD
C6405	VCKYCY1CF224Z	J 0.22	16V Ceramic	AA	C6556	VCKYCZ1HF103Z	J 0.01	50V Ceramic	AB
C6406	VCKYCY1CF224Z	J 0.22	16V Ceramic	AA	C6557	VCCCCZ1HH270J	J 27p	50V Ceramic	AB
C6419	VCKYCY1AF105Z	J 1	10V Ceramic	AC	C6558	VCKYCZ1HF103Z	J 0.01	50V Ceramic	AB
C6421	VCSATA1AJ335M	J 3.3	10V Tantalum	AC	C6559	VCKYCZ1HF103Z	J 0.01	50V Ceramic	AB
C6422	VCSATA1AJ335M	J 3.3	10V Tantalum	AC	C6560	VCKYCZ1HF103Z	J 0.01	50V Ceramic	AB
C6423	VCKYCY1AF105Z	J 1	10V Ceramic	AC	C6561	VCKYCZ1HF103Z	J 0.01	50V Ceramic	AB
C6424	VCKYCY1AF105Z	J 1	10V Ceramic	AC	C6562	VCSATA0JJ106M	J 10	6.3V Tantalum	AD
C6425	VCSATA1AJ106M	J 10	10V Tantalum	AC	C6563	VCKYCZ1HF103Z	J 0.01	50V Ceramic	AB
C6426	VCKYCY1AF105Z	J 1	10V Ceramic	AC	C6567	VCCCCZ1HH270J	J 27p	50V Ceramic	AB
C6428	VCKYCZ1HF103Z	J 0.01	50V Ceramic	AB	C6601	VCKYCZ1HB102K	J 1000p	50V Ceramic	AB
C6429	VCKYCZ1HB222K	J 2200p	50V Ceramic	AB	C6602	VCKYCZ1HB102K	J 1000p	50V Ceramic	AB
C6430	VCKYCY1AF105Z	J 1	10V Ceramic	AC	C6604	VCSAPD1CJ105M	J 1	16V Tantalum	AC
C6431	VCKYCY1AF105Z	J 1	10V Ceramic	AC	RESISTORS				
C6432	VCKYCZ1HB222K	J 2200p	50V Ceramic	AB	R401	VRS-CZ1JF000J	J 0	1/16W Metal Oxide	AA
C6435	VCKYCY1CB473K	J 0.047	16V Ceramic	AA	R406	VRS-CZ1JF105J	J 1M	1/16W Metal Oxide	AA
C6436	VCKYCY1CB473K	J 0.047	16V Ceramic	AA	R407	VRS-CZ1JF101J	J 100	1/16W Metal Oxide	AA
C6437	VCSATA0JJ156M	J 15	6.3V Tantalum	AC	R410	VRS-CZ1JF101J	J 100	1/16W Metal Oxide	AA
C6438	VCSATA0JJ156M	J 15	6.3V Tantalum	AC	R411	VRS-CZ1JF101J	J 100	1/16W Metal Oxide	AA
C6470	VCKYTV1AB105K	J 1	10V Ceramic	AD	R412	VRS-CZ1JF561J	J 560	1/16W Metal Oxide	AA
C6471	VCKYTV1AB105K	J 1	10V Ceramic	AD	R440	VRS-CZ1JF000J	J 0	1/16W Metal Oxide	AA
C6473	VCKYCZ1AF104Z	J 0.1	10V Ceramic	AB	R443	VRS-CZ1JF000J	J 0	1/16W Metal Oxide	AA
C6474	VCSATA1AJ106M	J 10	10V Tantalum	AC	R446	VRS-CZ1JF000J	J 0	1/16W Metal Oxide	AA
C6475	VCKYCY1AF105Z	J 1	10V Ceramic	AC	R499	VRS-CZ1JF101J	J 100	1/16W Metal Oxide	AA
C6476	VCKYCY1AF105Z	J 1	10V Ceramic	AC	R704	VRS-CZ1JF103J	J 10k	1/16W Metal Oxide	AA
C6477	VCKYCZ1AF104Z	J 0.1	10V Ceramic	AB	R707	VRS-CZ1JF272J	J 2.7k	1/16W Metal Oxide	AA
C6480	VCKYTV1AB105K	J 1	10V Ceramic	AD	R709	VRS-CZ1JF474F	J 470k	1/16W Metal Oxide	AB
C6481	VCKYTV1AB105K	J 1	10V Ceramic	AD	R710	VRS-CZ1JF823F	J 82k	1/16W Metal Oxide	AB
C6497	VCSATD1AJ157M	J 150	10V Tantalum	AG	R726	VRS-CZ1JF334J	J 330k	1/16W Metal Oxide	AA
C6498	VCSATD1AJ157M	J 150	10V Tantalum	AG	R727	VRS-CZ1JF102J	J 1k	1/16W Metal Oxide	AA
					R728	VRS-CZ1JF332J	J 3.3k	1/16W Metal Oxide	AA
					R729	VRS-CZ1JF332J	J 3.3k	1/16W Metal Oxide	AA

Ref. No.	Part No.	★	Description	Code	Ref. No.	Part No.	★	Description	Code
DUNTK2635QA01/00									
VCR PWB UNIT (Continued)									
R730	VRS-CZ1JF332J	J	3.3k 1/16W Metal Oxide	AA	R809	VRS-CZ1JF103J	J	10k 1/16W Metal Oxide	AA
R733	VRS-CZ1JF103J	J	10k 1/16W Metal Oxide	AA	R810	VRS-CZ1JF105J	J	1M 1/16W Metal Oxide	AA
R734	VRS-CZ1JF103J	J	10k 1/16W Metal Oxide	AA	R811	VRS-CZ1JF471J	J	470 1/16W Metal Oxide	AA
R735	VRS-CZ1JF103J	J	10k 1/16W Metal Oxide	AA	R812	VRS-CZ1JF101J	J	100 1/16W Metal Oxide	AA
R736	VRS-CZ1JF103J	J	10k 1/16W Metal Oxide	AA	R813	VRS-CZ1JF101J	J	100 1/16W Metal Oxide	AA
R738	VRS-CZ1JF102J	J	1k 1/16W Metal Oxide	AA	R814	VRS-CZ1JF101J	J	100 1/16W Metal Oxide	AA
R739	VRS-CZ1JF471J	J	470 1/16W Metal Oxide	AA	R815	VRS-CZ1JF101J	J	100 1/16W Metal Oxide	AA
R740	VRS-CZ1JF822J	J	8.2k 1/16W Metal Oxide	AA	R816	VRS-CZ1JF821J	J	820 1/16W Metal Oxide	AA
R742	VRK-SA1JF102J	J	1k 1/16W M. Composi.	AB	R820	VRS-CZ1JF101J	J	100 1/16W Metal Oxide	AA
R743	VRK-SA1JF102J	J	1k 1/16W M. Composi.	AB	R821	VRS-CZ1JF101J	J	100 1/16W Metal Oxide	AA
R745	VRK-SA1JF102J	J	1k 1/16W M. Composi.	AB	R822	VRS-CZ1JF101J	J	100 1/16W Metal Oxide	AA
R747	VRK-SA1JF102J	J	1k 1/16W M. Composi.	AB	R823	VRS-CZ1JF101J	J	100 1/16W Metal Oxide	AA
R749	VRS-CZ1JF102J	J	1k 1/16W Metal Oxide	AA	R824	VRS-CZ1JF391D	J	390 1/16W Metal Oxide	AB
R751	VRK-SA1JF102J	J	1k 1/16W M. Composi.	AB	R828	VRS-CZ1JF391D	J	390 1/16W Metal Oxide	AB
R753	VRK-SA1JF102J	J	1k 1/16W M. Composi.	AB	R830	VRS-CZ1JF393D	J	39k 1/16W Metal Oxide	AB
R755	VRK-SA1JF102J	J	1k 1/16W M. Composi.	AB	R831	VRS-CZ1JF223D	J	22k 1/16W Metal Oxide	AB
R758	VRK-SA1JF102J	J	1k 1/16W M. Composi.	AB	R832	VRS-CZ1JF113D	J	11k 1/16W Metal Oxide	AA
R760	VRS-CZ1JF102J	J	1k 1/16W Metal Oxide	AA	R833	VRS-CZ1JF391D	J	390 1/16W Metal Oxide	AB
R761	VRS-CZ1JF563J	J	56k 1/16W Metal Oxide	AA	R837	VRS-CZ1JF391D	J	390 1/16W Metal Oxide	AB
R762	VRS-CZ1JF223J	J	22k 1/16W Metal Oxide	AA	R838	VRS-CZ1JF393D	J	39k 1/16W Metal Oxide	AB
R763	VRS-CZ1JF103J	J	10k 1/16W Metal Oxide	AA	R839	VRS-CZ1JF223D	J	22k 1/16W Metal Oxide	AB
R764	VRS-CZ1JF103J	J	10k 1/16W Metal Oxide	AA	R840	VRS-CZ1JF113D	J	11k 1/16W Metal Oxide	AA
R765	VRS-CZ1JF103J	J	10k 1/16W Metal Oxide	AA	R841	VRS-CZ1JF273D	J	27k 1/16W Metal Oxide	AA
R766	VRS-CZ1JF683J	J	68k 1/16W Metal Oxide	AA	R842	VRS-CY1JF000J	J	0 1/16W Metal Oxide	AA
R767	VRS-CZ1JF393J	J	39k 1/16W Metal Oxide	AA	R845	VRS-CZ1JF102J	J	1k 1/16W Metal Oxide	AA
R768	VRS-CZ1JF000J	J	0 1/16W Metal Oxide	AA	R847	VRS-CZ1JF102J	J	1k 1/16W Metal Oxide	AA
R769	VRS-CZ1JF122J	J	1.2k 1/16W Metal Oxide	AA	R849	VRS-CZ1JF102J	J	1k 1/16W Metal Oxide	AA
R770	VRS-CZ1JF102J	J	1k 1/16W Metal Oxide	AA	R853	VRS-CZ1JF391J	J	390 1/16W Metal Oxide	AA
R771	VRS-CZ1JF102J	J	1k 1/16W Metal Oxide	AA	R854	VRS-CZ1JF101J	J	100 1/16W Metal Oxide	AA
R772	VRS-CZ1JF823J	J	82k 1/16W Metal Oxide	AA	R855	VRS-CZ1JF101J	J	100 1/16W Metal Oxide	AA
R778	VRK-SA1JF102J	J	1k 1/16W M. Composi.	AB	R856	VRS-CZ1JF101J	J	100 1/16W Metal Oxide	AA
R780	VRK-SA1JF102J	J	1k 1/16W M. Composi.	AB	R857	VRS-CZ1JF822J	J	8.2k 1/16W Metal Oxide	AA
R782	VRS-CZ1JF103J	J	10k 1/16W Metal Oxide	AA	R858	VRS-CZ1JF000J	J	0 1/16W Metal Oxide	AA
R783	VRS-CZ1JF104J	J	100k 1/16W Metal Oxide	AA	R859	VRS-CZ1JF124J	J	120k 1/16W Metal Oxide	AA
R785	VRK-SA1JF102J	J	1k 1/16W M. Composi.	AB	R861	VRS-CZ1JF183D	J	18k 1/16W Metal Oxide	AB
R786	VRK-SA1JF102J	J	1k 1/16W M. Composi.	AB	R863	VRS-CZ1JF103J	J	10k 1/16W Metal Oxide	AA
R787	VRK-SA1JF102J	J	1k 1/16W M. Composi.	AB	R865	VRS-CZ1JF273D	J	27k 1/16W Metal Oxide	AA
R788	VRK-SA1JF102J	J	1k 1/16W M. Composi.	AB	R867	VRS-CZ1JF512J	J	5.1k 1/16W Metal Oxide	AB
R791	VRS-CZ1JF103J	J	10k 1/16W Metal Oxide	AA	R869	VRS-CZ1JF101J	J	100 1/16W Metal Oxide	AA
R792	VRK-SA1JF102J	J	1k 1/16W M. Composi.	AB	R870	VRS-CZ1JF332J	J	3.3k 1/16W Metal Oxide	AA
R794	VRK-SA1JF102J	J	1k 1/16W M. Composi.	AB	R871	VRS-CZ1JF000J	J	0 1/16W Metal Oxide	AA
R795	VRS-CZ1JF102J	J	1k 1/16W Metal Oxide	AA	R874	VRS-CZ1JF273D	J	27k 1/16W Metal Oxide	AA
R798	VRS-CZ1JF104J	J	100k 1/16W Metal Oxide	AA	R875	VRS-CZ1JF102J	J	1k 1/16W Metal Oxide	AA
R799	VRS-CZ1JF102J	J	1k 1/16W Metal Oxide	AA	R876	VRS-CZ1JF102J	J	1k 1/16W Metal Oxide	AA
R800	VRS-CZ1JF223J	J	22k 1/16W Metal Oxide	AA	R877	VRS-CZ1JF102J	J	1k 1/16W Metal Oxide	AA
R801	VRS-CZ1JF473J	J	47k 1/16W Metal Oxide	AA	R880	VRS-CZ1JF101J	J	100 1/16W Metal Oxide	AA
R802	VRS-CZ1JF472J	J	4.7k 1/16W Metal Oxide	AA	R881	VRS-CZ1JF3R0J	J	3 1/16W Metal Oxide	AA
R803	VRS-CZ1JF472J	J	4.7k 1/16W Metal Oxide	AA	R882	VRS-CZ1JF3R0J	J	3 1/16W Metal Oxide	AA
R804	VRS-CZ1JF472J	J	4.7k 1/16W Metal Oxide	AA	R883	VRS-CZ1JF101J	J	100 1/16W Metal Oxide	AA
R805	VRS-CZ1JF683J	J	68k 1/16W Metal Oxide	AA	R885	VRS-CZ1JF000J	J	0 1/16W Metal Oxide	AA
R806	VRS-CZ1JF105J	J	1M 1/16W Metal Oxide	AA	R886	VRS-CZ1JF000J	J	0 1/16W Metal Oxide	AA
R807	VRS-CZ1JF683J	J	68k 1/16W Metal Oxide	AA	R889	VRS-CZ1JF102J	J	1k 1/16W Metal Oxide	AA
R808	VRS-CZ1JF103J	J	10k 1/16W Metal Oxide	AA	R890	VRS-CZ1JF000J	J	0 1/16W Metal Oxide	AA
					R900	VRS-TV1JD000J	J	0 1/16W Metal Oxide	AA
					R901	VRS-CZ1JF273J	J	27k 1/16W Metal Oxide	AA
					R902	VRS-CZ1JF223J	J	22k 1/16W Metal Oxide	AA

Ref. No.	Part No.	★	Description	Code	Ref. No.	Part No.	★	Description	Code
DUNTK2635QA01/00									
VCR PWB UNIT (Continued)									
R903	VRS-CZ1JF222J	J	2.2k 1/16W Metal Oxide	AA	R1407	VRS-CZ1JF102J	J	1k 1/16W Metal Oxide	AA
R904	VRS-CZ1JF682J	J	6.8k 1/16W Metal Oxide	AA	R1408	VRS-CZ1JF390J	J	39 1/16W Metal Oxide	AA
R905	VRS-CZ1JF472J	J	4.7k 1/16W Metal Oxide	AA	R1409	VRS-CZ1JF390J	J	39 1/16W Metal Oxide	AA
R906	VRS-CZ1JF121J	J	120 1/16W Metal Oxide	AA	R1411	VRS-CZ1JF123J	J	12k 1/16W Metal Oxide	AA
R907	VRS-CZ1JF101J	J	100 1/16W Metal Oxide	AA	R1412	VRS-CZ1JF273J	J	27k 1/16W Metal Oxide	AA
R908	VRS-CZ1JF000J	J	0 1/16W Metal Oxide	AA	R1415	VRS-CZ1JF103J	J	10k 1/16W Metal Oxide	AA
R909	VRS-CZ1JF102D	J	1k 1/16W Metal Oxide	AA	R1419	VRS-CZ1JF102J	J	1k 1/16W Metal Oxide	AA
R910	VRS-CZ1JF223D	J	22k 1/16W Metal Oxide	AB	R1420	VRS-CZ1JF102J	J	1k 1/16W Metal Oxide	AA
R911	VRS-CY1JFR22J	J	0.22 1/16W Metal Oxide	AA	R1422	VRS-CZ1JF000J	J	0 1/16W Metal Oxide	AA
R913	VRS-TV1JD471J	J	470 1/16W Metal Oxide	AA	R1423	VRS-CZ1JF390J	J	39 1/16W Metal Oxide	AA
R914	VRS-CZ1JF104J	J	100k 1/16W Metal Oxide	AA	R1424	VRS-CZ1JF330J	J	33 1/16W Metal Oxide	AA
R915	VRS-CZ1JF471J	J	470 1/16W Metal Oxide	AA	R1425	VRS-CZ1JF102J	J	1k 1/16W Metal Oxide	AA
R916	VRS-CZ1JF560J	J	56 1/16W Metal Oxide	AA	R1426	VRS-CZ1JF102J	J	1k 1/16W Metal Oxide	AA
R918	VRS-CZ1JF000J	J	0 1/16W Metal Oxide	AA	R1427	VRS-CZ1JF102J	J	1k 1/16W Metal Oxide	AA
R921	VRS-TV1JD471J	J	470 1/16W Metal Oxide	AA	R1428	VRS-CZ1JF102J	J	1k 1/16W Metal Oxide	AA
R922	VRS-CZ1JF471J	J	470 1/16W Metal Oxide	AA	R1429	VRS-CZ1JF390J	J	39 1/16W Metal Oxide	AA
R924	VRS-CZ1JF000J	J	0 1/16W Metal Oxide	AA	R1430	VRS-CZ1JF390J	J	39 1/16W Metal Oxide	AA
R928	VRS-CZ1JF000J	J	0 1/16W Metal Oxide	AA	R1431	VRS-CZ1JF222J	J	2.2k 1/16W Metal Oxide	AA
R931	VRS-TV1JD332J	J	3.3k 1/16W Metal Oxide	AA	R1432	VRS-CZ1JF561J	J	560 1/16W Metal Oxide	AA
R932	VRS-TV1JD471J	J	470 1/16W Metal Oxide	AA	R1433	VRS-CZ1JF561J	J	560 1/16W Metal Oxide	AA
R935	VRS-CZ1JF271J	J	270 1/16W Metal Oxide	AA	R1435	VRS-CZ1JF101J	J	100 1/16W Metal Oxide	AA
R936	VRS-CZ1JF433D	J	43k 1/16W Metal Oxide	AA	R1436	VRS-CZ1JF000J	J	0 1/16W Metal Oxide	AA
R937	VRS-CZ1JF303D	J	30k 1/16W Metal Oxide	AA	R1437	VRS-CZ1JF561J	J	560 1/16W Metal Oxide	AA
R938	VRS-TV1JD000J	J	0 1/16W Metal Oxide	AA	R1439	VRS-CZ1JF273J	J	27k 1/16W Metal Oxide	AA
R941	VRS-CZ1JF561D	J	560 1/16W Metal Oxide	AA	R1440	VRS-CZ1JF223J	J	22k 1/16W Metal Oxide	AA
R943	VRS-CZ1JF392D	J	3.9k 1/16W Metal Oxide	AB	R1441	VRS-CZ1JF152J	J	1.5k 1/16W Metal Oxide	AA
R944	VRS-CZ1JF273J	J	27k 1/16W Metal Oxide	AA	R1442	VRS-CZ1JF681J	J	680 1/16W Metal Oxide	AA
R946	VRS-CZ1JF222J	J	2.2k 1/16W Metal Oxide	AA	R1443	VRS-CZ1JF561J	J	560 1/16W Metal Oxide	AA
R947	VRS-CZ1JF433D	J	43k 1/16W Metal Oxide	AA	R1444	VRS-CZ1JF122J	J	1.2k 1/16W Metal Oxide	AA
R949	VRS-CZ1JF392D	J	3.9k 1/16W Metal Oxide	AB	R1445	VRS-CZ1JF101J	J	100 1/16W Metal Oxide	AA
R952	VRS-CZ1JF273J	J	27k 1/16W Metal Oxide	AA	R1446	VRS-CZ1JF152J	J	1.5k 1/16W Metal Oxide	AA
R953	VRS-CZ1JF473J	J	47k 1/16W Metal Oxide	AA	R1448	VRS-CZ1JF472J	J	4.7k 1/16W Metal Oxide	AA
R955	VRS-CZ1JF271J	J	270 1/16W Metal Oxide	AA	R1449	VRS-CZ1JF473J	J	47k 1/16W Metal Oxide	AA
R964	VRS-TV1JD222J	J	2.2k 1/16W Metal Oxide	AA	R1450	VRS-CZ1JF222J	J	2.2k 1/16W Metal Oxide	AA
R966	VRS-TV1JD000J	J	0 1/16W Metal Oxide	AA	R1451	VRS-CZ1JF392J	J	3.9k 1/16W Metal Oxide	AA
R968	VRS-TV1JD000J	J	0 1/16W Metal Oxide	AA	R1452	VRS-CZ1JF105J	J	1M 1/16W Metal Oxide	AA
R969	VRS-TV1JD000J	J	0 1/16W Metal Oxide	AA	R1453	VRS-CZ1JF272J	J	2.7k 1/16W Metal Oxide	AA
R973	VRS-CZ1JF473J	J	47k 1/16W Metal Oxide	AA	R1454	VRS-CZ1JF101J	J	100 1/16W Metal Oxide	AA
R975	VRS-CZ1JF472J	J	4.7k 1/16W Metal Oxide	AA	R1455	VRS-CZ1JF222J	J	2.2k 1/16W Metal Oxide	AA
R976	VRS-CY1JF1R0J	J	1 1/16W Metal Oxide	AA	R1456	VRS-CZ1JF562J	J	5.6k 1/16W Metal Oxide	AA
R977	VRS-CZ1JF683D	J	68k 1/16W Metal Oxide	AB	R1458	VRS-CZ1JF101J	J	100 1/16W Metal Oxide	AA
R979	VRS-CZ1JF223D	J	22k 1/16W Metal Oxide	AB	R1460	VRS-CZ1JF153J	J	15k 1/16W Metal Oxide	AA
R981	VRS-CZ1JF104D	J	100k 1/16W Metal Oxide	AB	R1461	VRS-CZ1JF392J	J	3.9k 1/16W Metal Oxide	AA
R983	VRS-CZ1JF363D	J	36k 1/16W Metal Oxide	AA	R1462	VRS-CY1JF000J	J	0 1/16W Metal Oxide	AA
R984	VRS-CZ1JF105J	J	1M 1/16W Metal Oxide	AA	R1463	VRS-CZ1JF273J	J	27k 1/16W Metal Oxide	AA
R990	VRS-CZ1JF271J	J	270 1/16W Metal Oxide	AA	R1464	VRS-CZ1JF223J	J	22k 1/16W Metal Oxide	AA
R991	VRS-CZ1JF561J	J	560 1/16W Metal Oxide	AA	R1465	VRS-CZ1JF152J	J	1.5k 1/16W Metal Oxide	AA
R992	VRS-TV1JD220J	J	22 1/16W Metal Oxide	AA	R1466	VRS-CZ1JF681J	J	680 1/16W Metal Oxide	AA
R1401	VRS-CZ1JF103J	J	10k 1/16W Metal Oxide	AA	R1467	VRS-CZ1JF122J	J	1.2k 1/16W Metal Oxide	AA
R1403	VRS-CZ1JF000J	J	0 1/16W Metal Oxide	AA	R1468	VRS-CY1JF330J	J	33 1/16W Metal Oxide	AA
R1404	VRS-CZ1JF103J	J	10k 1/16W Metal Oxide	AA	R1469	VRS-CZ1JF000J	J	0 1/16W Metal Oxide	AA
R1405	VRS-CZ1JF104J	J	100k 1/16W Metal Oxide	AA	R1470	VRS-CZ1JF102J	J	1k 1/16W Metal Oxide	AA
R1406	VRS-CZ1JF103J	J	10k 1/16W Metal Oxide	AA	R1471	VRS-CZ1JF102J	J	1k 1/16W Metal Oxide	AA
					R1487	VRS-CZ1JF000J	J	0 1/16W Metal Oxide	AA
					R1489	VRS-CZ1JF000J	J	0 1/16W Metal Oxide	AA
					R1498	VRS-CZ1JF222J	J	2.2k 1/16W Metal Oxide	AA

Ref. No.	Part No.	★	Description	Code	Ref. No.	Part No.	★	Description	Code
DUNTK2635QA01/00									
VCR PWB UNIT (Continued)									
R1499	VRS-CZ1JF822J	J	8.2k 1/16W	Metal Oxide AA	R1906	VRS-CZ1JF153D	J	15k 1/16W	Metal Oxide AB
R1702	VRS-CZ1JF1R0J	J	1 1/16W	Metal Oxide AA	R1907	VRS-CZ1JF123D	J	12k 1/16W	Metal Oxide AA
R1706	VRS-CZ1JF474J	J	470k 1/16W	Metal Oxide AA	R1908	VRS-CZ1JF104J	J	100k 1/16W	Metal Oxide AA
R1707	VRS-CZ1JF105J	J	1M 1/16W	Metal Oxide AA	R1910	VRS-CZ1JF433D	J	43k 1/16W	Metal Oxide AA
R1708	VRS-CZ1JF1R0J	J	1 1/16W	Metal Oxide AA	R1911	VRS-CZ1JF682D	J	6.8k 1/16W	Metal Oxide AB
R1709	VRS-CZ1JF103J	J	10k 1/16W	Metal Oxide AA	R1912	VRS-CZ1JF433D	J	43k 1/16W	Metal Oxide AA
R1710	VRS-CZ1JF223J	J	22k 1/16W	Metal Oxide AA	R1913	VRS-CZ1JF123D	J	12k 1/16W	Metal Oxide AA
R1711	VRS-CZ1JF103J	J	10k 1/16W	Metal Oxide AA	R1914	VRS-CZ1JF105J	J	1M 1/16W	Metal Oxide AA
R1720	VRS-CZ1JF223J	J	22k 1/16W	Metal Oxide AA	R1915	VRS-CZ1JF104D	J	100k 1/16W	Metal Oxide AB
R1721	VRS-CZ1JF621J	J	620 1/16W	Metal Oxide AA	R1916	VRS-CZ1JF433D	J	43k 1/16W	Metal Oxide AA
R1722	VRS-CZ1JF331J	J	330 1/16W	Metal Oxide AA	R1917	VRS-CZ1JF122D	J	1.2k 1/16W	Metal Oxide AB
R1732	VRS-CZ1JF103J	J	10k 1/16W	Metal Oxide AA	R1918	VRS-CZ1JF163D	J	16k 1/16W	Metal Oxide AA
R1733	VRS-CZ1JF000J	J	0 1/16W	Metal Oxide AA	R1919	VRS-CZ1JF123D	J	12k 1/16W	Metal Oxide AA
R1740	VRS-CZ1JF103J	J	10k 1/16W	Metal Oxide AA	R1920	VRS-CZ1JF104J	J	100k 1/16W	Metal Oxide AA
R1741	VRS-CZ1JF103J	J	10k 1/16W	Metal Oxide AA	R1921	VRS-CZ1JF683D	J	68k 1/16W	Metal Oxide AB
R1742	VRS-CZ1JF103J	J	10k 1/16W	Metal Oxide AA	R1922	VRS-CZ1JF104D	J	100k 1/16W	Metal Oxide AB
R1743	VRS-CZ1JF000J	J	0 1/16W	Metal Oxide AA	R1923	VRS-CZ1JF752D	J	7.5k 1/16W	Metal Oxide AA
R1744	VRS-CZ1JF000J	J	0 1/16W	Metal Oxide AA	R1924	VRS-CZ1JF622D	J	6.2k 1/16W	Metal Oxide AA
R1751	VRS-CZ1JF222J	J	2.2k 1/16W	Metal Oxide AA	R1925	VRS-CZ1JF472D	J	4.7k 1/16W	Metal Oxide AB
R1752	VRS-CZ1JF562J	J	5.6k 1/16W	Metal Oxide AA	R1926	VRS-CZ1JF274J	J	270k 1/16W	Metal Oxide AA
R1757	VRS-CZ1JF102J	J	1k 1/16W	Metal Oxide AA	R1927	VRS-CZ1JF104D	J	100k 1/16W	Metal Oxide AB
R1765	VRS-CZ1JF000J	J	0 1/16W	Metal Oxide AA	R1928	VRS-CZ1JF563D	J	56k 1/16W	Metal Oxide AA
R1770	VRS-CZ1JF103J	J	10k 1/16W	Metal Oxide AA	R1929	VRS-CZ1JF391J	J	390 1/16W	Metal Oxide AA
R1771	VRS-CZ1JF103J	J	10k 1/16W	Metal Oxide AA	R1930	VRS-CZ1JF273D	J	27k 1/16W	Metal Oxide AA
R1772	VRS-CZ1JF102J	J	1k 1/16W	Metal Oxide AA	R1931	VRS-CZ1JF182D	J	1.8k 1/16W	Metal Oxide AB
R1773	VRS-CZ1JF102J	J	1k 1/16W	Metal Oxide AA	R1932	VRS-CZ1JF123D	J	12k 1/16W	Metal Oxide AA
R1774	VRS-CZ1JF822J	J	8.2k 1/16W	Metal Oxide AA	R1933	VRS-CZ1JF104J	J	100k 1/16W	Metal Oxide AA
R1775	VRS-CZ1JF473J	J	47k 1/16W	Metal Oxide AA	R1934	VRS-CZ1JF823D	J	82k 1/16W	Metal Oxide AB
R1776	VRS-CZ1JF102J	J	1k 1/16W	Metal Oxide AA	R1935	VRS-CZ1JF104D	J	100k 1/16W	Metal Oxide AB
R1777	VRS-CZ1JF102J	J	1k 1/16W	Metal Oxide AA	R1936	VRS-CZ1JF912D	J	9.1k 1/16W	Metal Oxide AA
R1778	VRS-CZ1JF102J	J	1k 1/16W	Metal Oxide AA	R1937	VRS-CZ1JF103D	J	10k 1/16W	Metal Oxide AB
R1779	VRS-CZ1JF102J	J	1k 1/16W	Metal Oxide AA	R1938	VRS-CZ1JF000J	J	0 1/16W	Metal Oxide AA
R1780	VRS-CZ1JF103J	J	10k 1/16W	Metal Oxide AA	R1939	VRS-CZ1JF472D	J	4.7k 1/16W	Metal Oxide AB
R1781	VRS-CZ1JF103J	J	10k 1/16W	Metal Oxide AA	R1940	VRS-CZ1JF183D	J	18k 1/16W	Metal Oxide AB
R1782	VRS-CZ1JF102J	J	1k 1/16W	Metal Oxide AA	R1941	VRS-CZ1JF104J	J	100k 1/16W	Metal Oxide AA
R1783	VRS-CZ1JF102J	J	1k 1/16W	Metal Oxide AA	R1942	VRS-CZ1JF104D	J	100k 1/16W	Metal Oxide AB
R1785	VRS-CZ1JF102J	J	1k 1/16W	Metal Oxide AA	R1943	VRS-CZ1JF393D	J	39k 1/16W	Metal Oxide AB
R1786	VRS-CZ1JF473J	J	47k 1/16W	Metal Oxide AA	R1944	VRS-CZ1JF104J	J	100k 1/16W	Metal Oxide AA
R1787	VRS-CZ1JF822J	J	8.2k 1/16W	Metal Oxide AA	R1945	VRS-CZ1JF104J	J	100k 1/16W	Metal Oxide AA
R1790	VRS-CZ1JF120J	J	12 1/16W	Metal Oxide AB	R1946	VRS-CZ1JF333J	J	33k 1/16W	Metal Oxide AA
R1791	VRS-CZ1JF120J	J	12 1/16W	Metal Oxide AB	R1947	VRS-CZ1JF333J	J	33k 1/16W	Metal Oxide AA
R1792	VRS-CZ1JF272J	J	2.7k 1/16W	Metal Oxide AA	R1948	VRS-CZ1JF332J	J	3.3k 1/16W	Metal Oxide AA
R1793	VRS-CZ1JF102J	J	1k 1/16W	Metal Oxide AA	R1949	VRS-CZ1JF683J	J	68k 1/16W	Metal Oxide AA
R1794	VRS-CZ1JF272J	J	2.7k 1/16W	Metal Oxide AA	R1951	VRS-CZ1JF104J	J	100k 1/16W	Metal Oxide AA
R1795	VRS-CZ1JF102J	J	1k 1/16W	Metal Oxide AA	R1952	VRS-CZ1JF000J	J	0 1/16W	Metal Oxide AA
R1796	VRS-CZ1JF102J	J	1k 1/16W	Metal Oxide AA	R1953	VRS-CZ1JF392J	J	3.9k 1/16W	Metal Oxide AA
R1797	VRS-CZ1JF000J	J	0 1/16W	Metal Oxide AA	R1954	VRS-CZ1JF562J	J	5.6k 1/16W	Metal Oxide AA
R1798	VRS-CZ1JF000J	J	0 1/16W	Metal Oxide AA	R1955	VRS-CZ1JF182J	J	1.8k 1/16W	Metal Oxide AA
R1799	VRS-CZ1JF103J	J	10k 1/16W	Metal Oxide AA	R1957	VRS-CZ1JF182J	J	1.8k 1/16W	Metal Oxide AA
R1823	VRS-CZ1JF822J	J	8.2k 1/16W	Metal Oxide AA	R1959	VRS-CZ1JF104J	J	100k 1/16W	Metal Oxide AA
R1901	VRN-CZ1JF432D	J	4.3k 1/16W	Metal Film AA	R1960	VRS-CZ1JF821J	J	820 1/16W	Metal Oxide AA
R1904	VRS-CZ1JF104J	J	100k 1/16W	Metal Oxide AA	R1961	VRS-CY1JF220J	J	22 1/16W	Metal Oxide AA
R1905	VRS-CZ1JF000J	J	0 1/16W	Metal Oxide AA	R1962	VRS-CZ1JF681J	J	680 1/16W	Metal Oxide AA
					R1963	VRS-CZ1JF301J	J	300 1/16W	Metal Oxide AB
					R1964	VRS-CY1JF560J	J	56 1/16W	Metal Oxide AA
					R1965	VRS-CY1JF560J	J	56 1/16W	Metal Oxide AA

Ref. No.	Part No.	★	Description	Code	Ref. No.	Part No.	★	Description	Code
DUNTK2635QA01/00									
VCR PWB UNIT (Continued)									
R1966	VRS-CY1JF330J	J	33 1/16W Metal Oxide	AA	R3464	VRS-CZ1JF152J	J	1.5k 1/16W Metal Oxide	AA
R1967	VRS-CZ1JF104D	J	100k 1/16W Metal Oxide	AB	R3465	VRS-CZ1JF101J	J	100 1/16W Metal Oxide	AA
R1968	VRS-CZ1JF103D	J	10k 1/16W Metal Oxide	AB	R3466	VRS-CZ1JF152J	J	1.5k 1/16W Metal Oxide	AA
R1969	VRS-CZ1JF333D	J	33k 1/16W Metal Oxide	AB	R3469	VRS-CZ1JF102J	J	1k 1/16W Metal Oxide	AA
R1970	VRS-CZ1JF123D	J	12k 1/16W Metal Oxide	AA	R3470	VRS-CZ1JF103J	J	10k 1/16W Metal Oxide	AA
R1972	VRS-CZ1JF000J	J	0 1/16W Metal Oxide	AA	R3471	VRS-CZ1JF221J	J	220 1/16W Metal Oxide	AA
R1973	VRS-CZ1JF273D	J	27k 1/16W Metal Oxide	AA	R3472	VRS-CZ1JF101J	J	100 1/16W Metal Oxide	AA
R1974	VRS-CZ1JF123D	J	12k 1/16W Metal Oxide	AA	R3474	VRS-CZ1JF102J	J	1k 1/16W Metal Oxide	AA
R1975	VRS-CZ1JF103D	J	10k 1/16W Metal Oxide	AB	R3475	VRS-CZ1JF471J	J	470 1/16W Metal Oxide	AA
R1979	VRS-CZ1JF000J	J	0 1/16W Metal Oxide	AA	R3476	VRS-CZ1JF153F	J	15k 1/16W Metal Oxide	AA
R1980	VRS-CZ1JF000J	J	0 1/16W Metal Oxide	AA	R3477	VRS-CZ1JF103F	J	10k 1/16W Metal Oxide	AB
R2400	VRS-CY1JF000J	J	0 1/16W Metal Oxide	AA	R3479	VRS-CZ1JF102J	J	1k 1/16W Metal Oxide	AA
R2424	VRS-CZ1JF000J	J	0 1/16W Metal Oxide	AA	R3481	VRS-CZ1JF121J	J	120 1/16W Metal Oxide	AA
R2439	VRS-CY1JF000J	J	0 1/16W Metal Oxide	AA	R3482	VRS-CZ1JF122J	J	1.2k 1/16W Metal Oxide	AA
R2480	VRS-CY1JF000J	J	0 1/16W Metal Oxide	AA	R3483	VRS-CZ1JF391J	J	390 1/16W Metal Oxide	AA
R2481	VRS-CZ1JF561J	J	560 1/16W Metal Oxide	AA	R3484	VRS-CZ1JF181J	J	180 1/16W Metal Oxide	AA
R2702	VRS-CZ1JF122J	J	1.2k 1/16W Metal Oxide	AA	R3485	VRS-CZ1JF271J	J	270 1/16W Metal Oxide	AA
R2703	VRS-CZ1JF104J	J	100k 1/16W Metal Oxide	AA	R3486	VRS-CZ1JF102J	J	1k 1/16W Metal Oxide	AA
R2704	VRS-CZ1JF334J	J	330k 1/16W Metal Oxide	AA	R3487	VRS-CZ1JF151J	J	150 1/16W Metal Oxide	AA
R2705	VRS-CZ1JF000J	J	0 1/16W Metal Oxide	AA	R3488	VRS-CZ1JF391J	J	390 1/16W Metal Oxide	AA
R2706	VRS-CZ1JF563J	J	56k 1/16W Metal Oxide	AA	R3489	VRS-CZ1JF221J	J	220 1/16W Metal Oxide	AA
R2707	VRS-CZ1JF473J	J	47k 1/16W Metal Oxide	AA	R3491	VRS-CZ1JF221J	J	220 1/16W Metal Oxide	AA
R2745	VRS-CZ1JF103J	J	10k 1/16W Metal Oxide	AA	R3492	VRS-CZ1JF151J	J	150 1/16W Metal Oxide	AA
R3401	VRS-CZ1JF152J	J	1.5k 1/16W Metal Oxide	AA	R3494	VRS-CZ1JF222J	J	2.2k 1/16W Metal Oxide	AA
R3402	VRS-CZ1JF152J	J	1.5k 1/16W Metal Oxide	AA	R3496	VRS-CZ1JF121J	J	120 1/16W Metal Oxide	AA
R3406	VRS-CZ1JF182J	J	1.8k 1/16W Metal Oxide	AA	R3497	VRK-SA1JF102J	J	1k 1/16W M. Composi.	AB
R3407	VRS-CZ1JF182J	J	1.8k 1/16W Metal Oxide	AA	R3501	VRS-CZ1JF102J	J	1k 1/16W Metal Oxide	AA
R3408	VRS-CZ1JF152J	J	1.5k 1/16W Metal Oxide	AA	R3503	VRS-CZ1JF333J	J	33k 1/16W Metal Oxide	AA
R3409	VRS-CZ1JF152J	J	1.5k 1/16W Metal Oxide	AA	R3509	VRS-CZ1JF102J	J	1k 1/16W Metal Oxide	AA
R3411	VRS-CZ1JF331J	J	330 1/16W Metal Oxide	AA	R3510	VRS-CZ1JF181J	J	180 1/16W Metal Oxide	AA
R3415	VRS-CZ1JF123J	J	12k 1/16W Metal Oxide	AA	R3511	VRS-CZ1JF221J	J	220 1/16W Metal Oxide	AA
R3416	VRS-CZ1JF223J	J	22k 1/16W Metal Oxide	AA	R3512	VRS-CZ1JF561J	J	560 1/16W Metal Oxide	AA
R3417	VRS-CZ1JF273J	J	27k 1/16W Metal Oxide	AA	R3513	VRS-CZ1JF182J	J	1.8k 1/16W Metal Oxide	AA
R3419	VRS-CZ1JF301J	J	300 1/16W Metal Oxide	AB	R3514	VRS-CZ1JF182J	J	1.8k 1/16W Metal Oxide	AA
R3421	VRS-CZ1JF222J	J	2.2k 1/16W Metal Oxide	AA	R3515	VRS-CZ1JF182J	J	1.8k 1/16W Metal Oxide	AA
R3422	VRS-CZ1JF391J	J	390 1/16W Metal Oxide	AA	R3516	VRS-CZ1JF182J	J	1.8k 1/16W Metal Oxide	AA
R3424	VRS-CZ1JF152J	J	1.5k 1/16W Metal Oxide	AA	R3517	VRS-CZ1JF151J	J	150 1/16W Metal Oxide	AA
R3428	VRS-CZ1JF102J	J	1k 1/16W Metal Oxide	AA	R3518	VRS-CZ1JF102J	J	1k 1/16W Metal Oxide	AA
R3429	VRS-CZ1JF152J	J	1.5k 1/16W Metal Oxide	AA	R3523	VRS-CY1JF000J	J	0 1/16W Metal Oxide	AA
R3443	VRK-SA1JF103J	J	10k 1/16W M. Composi.	AB	R3526	VRS-CZ1JF561J	J	560 1/16W Metal Oxide	AA
R3444	VRK-SA1JF102J	J	1k 1/16W M. Composi.	AB	R3527	VRS-CZ1JF151J	J	150 1/16W Metal Oxide	AA
R3447	VRS-CZ1JF333J	J	33k 1/16W Metal Oxide	AA	R3528	VRS-CZ1JF222J	J	2.2k 1/16W Metal Oxide	AA
R3448	VRS-CZ1JF333J	J	33k 1/16W Metal Oxide	AA	R3529	VRS-CZ1JF392J	J	3.9k 1/16W Metal Oxide	AA
R3449	VRS-CZ1JF103J	J	10k 1/16W Metal Oxide	AA	R3530	VRS-CZ1JF182J	J	1.8k 1/16W Metal Oxide	AA
R3453	VRS-CZ1JF103J	J	10k 1/16W Metal Oxide	AA	R3601	VRS-CZ1JF331J	J	330 1/16W Metal Oxide	AA
R3454	VRS-CZ1JF152J	J	1.5k 1/16W Metal Oxide	AA	R3602	<i>See Control</i>			
R3455	VRS-CZ1JF152J	J	1.5k 1/16W Metal Oxide	AA	R3603	VRS-CZ1JF152J	J	1.5k 1/16W Metal Oxide	AA
R3458	VRS-CZ1JF103J	J	10k 1/16W Metal Oxide	AA	R3604	VRS-CZ1JF471J	J	470 1/16W Metal Oxide	AA
R3459	VRS-CZ1JF330J	J	33 1/16W Metal Oxide	AA	R3605	VRS-CZ1JF681J	J	680 1/16W Metal Oxide	AA
R3460	VRS-CZ1JF332J	J	3.3k 1/16W Metal Oxide	AA	R3606	VRS-CZ1JF153J	J	15k 1/16W Metal Oxide	AA
R3461	VRS-CZ1JF330J	J	33 1/16W Metal Oxide	AA	R3607	VRS-CZ1JF103J	J	10k 1/16W Metal Oxide	AA
R3462	VRS-CZ1JF332J	J	3.3k 1/16W Metal Oxide	AA	R3608	VRS-CZ1JF103J	J	10k 1/16W Metal Oxide	AA
R3463	VRS-CZ1JF101J	J	100 1/16W Metal Oxide	AA	R3609	VRS-CZ1JF103J	J	10k 1/16W Metal Oxide	AA
					R3610	VRS-CZ1JF152J	J	1.5k 1/16W Metal Oxide	AA
					R3611	VRS-CZ1JF272J	J	2.7k 1/16W Metal Oxide	AA
					R3613	VRS-CZ1JF102J	J	1k 1/16W Metal Oxide	AA

Ref. No.	Part No.	★	Description	Code	Ref. No.	Part No.	★	Description	Code
DUNTK2635QA01/00									
VCR PWB UNIT (Continued)									
R3614	VRS-CZ1JF000J	J 0	1/16W Metal Oxide	AA	R4590	VRK-SA1JF101J	J 100	1/16W M. Composi.	AB
R3618	VRS-CZ1JF000J	J 0	1/16W Metal Oxide	AA	R4591	VRK-SA1JF101J	J 100	1/16W M. Composi.	AB
R3620	VRS-CZ1JF222J	J 2.2k	1/16W Metal Oxide	AA	R4592	VRK-SA1JF101J	J 100	1/16W M. Composi.	AB
R3621	VRS-CZ1JF000J	J 0	1/16W Metal Oxide	AA	R4593	VRK-SA1JF101J	J 100	1/16W M. Composi.	AB
R3702	VRK-SA1JF102J	J 1k	1/16W M. Composi.	AB	R4594	VRK-SA1JF101J	J 100	1/16W M. Composi.	AB
R3721	VRS-CZ1JF102J	J 1k	1/16W Metal Oxide	AA	R4595	VRS-CZ1JF101J	J 100	1/16W Metal Oxide	AA
R3722	VRS-CZ1JF102J	J 1k	1/16W Metal Oxide	AA	R4596	VRK-SA1JF101J	J 100	1/16W M. Composi.	AB
R3723	VRS-CZ1JF000J	J 0	1/16W Metal Oxide	AA	R4597	VRK-SA1JF101J	J 100	1/16W M. Composi.	AB
R3724	VRS-CZ1JF000J	J 0	1/16W Metal Oxide	AA	R4598	VRK-SA1JF101J	J 100	1/16W M. Composi.	AB
R3725	VRS-CZ1JF000J	J 0	1/16W Metal Oxide	AA	R4599	VRK-SA1JF101J	J 100	1/16W M. Composi.	AB
R3726	VRS-CZ1JF000J	J 0	1/16W Metal Oxide	AA	R4701	VRK-SA1JF102J	J 1k	1/16W M. Composi.	AB
R3727	VRS-CZ1JF000J	J 0	1/16W Metal Oxide	AA	R4702	VRK-SA1JF102J	J 1k	1/16W M. Composi.	AB
R3728	VRS-CZ1JF000J	J 0	1/16W Metal Oxide	AA	R4703	VRK-SA1JF102J	J 1k	1/16W M. Composi.	AB
R3729	VRS-CZ1JF000J	J 0	1/16W Metal Oxide	AA	R4704	VRS-CZ1JF102J	J 1k	1/16W Metal Oxide	AA
R3730	VRS-CZ1JF000J	J 0	1/16W Metal Oxide	AA	R4705	VRK-SA1JF102J	J 1k	1/16W M. Composi.	AB
R3731	VRS-CZ1JF000J	J 0	1/16W Metal Oxide	AA	R4706	VRK-SA1JF102J	J 1k	1/16W M. Composi.	AB
R3753	VRS-CZ1JF102J	J 1k	1/16W Metal Oxide	AA	R4707	VRK-SA1JF102J	J 1k	1/16W M. Composi.	AB
R3754	VRS-CZ1JF102J	J 1k	1/16W Metal Oxide	AA	R4708	VRK-SA1JF102J	J 1k	1/16W M. Composi.	AB
R3755	VRS-CZ1JF102J	J 1k	1/16W Metal Oxide	AA	R4709	VRS-CZ1JF104J	J 100k	1/16W Metal Oxide	AA
R3759	VRS-CZ1JF102J	J 1k	1/16W Metal Oxide	AA	R4710	VRK-SA1JF102J	J 1k	1/16W M. Composi.	AB
R3799	VRS-CZ1JF000J	J 0	1/16W Metal Oxide	AA	R4711	VRS-CZ1JF102J	J 1k	1/16W Metal Oxide	AA
R4402	VRS-CZ1JF102J	J 1k	1/16W Metal Oxide	AA	R4712	VRK-SA1JF102J	J 1k	1/16W M. Composi.	AB
R4403	VRS-CZ1JF103J	J 10k	1/16W Metal Oxide	AA	R4713	VRK-SA1JF102J	J 1k	1/16W M. Composi.	AB
R4404	VRS-CZ1JF102J	J 1k	1/16W Metal Oxide	AA	R4715	VRK-SA1JF102J	J 1k	1/16W M. Composi.	AB
R4405	VRS-CZ1JF474J	J 470k	1/16W Metal Oxide	AA	R4719	VRK-SA1JF102J	J 1k	1/16W M. Composi.	AB
R4406	VRS-CZ1JF102J	J 1k	1/16W Metal Oxide	AA	R4721	VRS-CZ1JF102J	J 1k	1/16W Metal Oxide	AA
R4407	VRS-CZ1JF474J	J 470k	1/16W Metal Oxide	AA	R4722	VRS-CZ1JF102J	J 1k	1/16W Metal Oxide	AA
R4408	VRS-CZ1JF103J	J 10k	1/16W Metal Oxide	AA	R4723	VRS-CZ1JF102J	J 1k	1/16W Metal Oxide	AA
R4409	VRS-CZ1JF102J	J 1k	1/16W Metal Oxide	AA	R4725	VRS-CZ1JF102J	J 1k	1/16W Metal Oxide	AA
R4412	VRS-CZ1JF000J	J 0	1/16W Metal Oxide	AA	R4726	VRK-SA1JF102J	J 1k	1/16W M. Composi.	AB
R4416	VRS-CZ1JF102J	J 1k	1/16W Metal Oxide	AA	R4727	VRS-CZ1JF102J	J 1k	1/16W Metal Oxide	AA
R4417	VRS-CZ1JF103J	J 10k	1/16W Metal Oxide	AA	R4729	VRK-SA1JF102J	J 1k	1/16W M. Composi.	AB
R4418	VRS-CZ1JF102J	J 1k	1/16W Metal Oxide	AA	R4730	VRK-SA1JF102J	J 1k	1/16W M. Composi.	AB
R4419	VRS-CZ1JF103J	J 10k	1/16W Metal Oxide	AA	R4731	VRK-SA1JF102J	J 1k	1/16W M. Composi.	AB
R4420	VRS-CZ1JF104J	J 100k	1/16W Metal Oxide	AA	R4732	VRS-CZ1JF102J	J 1k	1/16W Metal Oxide	AA
R4421	VRS-CZ1JF104J	J 100k	1/16W Metal Oxide	AA	R4733	VRS-CZ1JF102J	J 1k	1/16W Metal Oxide	AA
R4422	VRS-CZ1JF104J	J 100k	1/16W Metal Oxide	AA	R4770	VRS-CZ1JF102J	J 1k	1/16W Metal Oxide	AA
R4423	VRS-CZ1JF104J	J 100k	1/16W Metal Oxide	AA	R4772	VRS-CZ1JF102J	J 1k	1/16W Metal Oxide	AA
R4431	VRS-CY1JF330J	J 33	1/16W Metal Oxide	AA	R4776	VRS-CZ1JF000J	J 0	1/16W Metal Oxide	AA
R4441	VRS-CZ1JF332J	J 3.3k	1/16W Metal Oxide	AA	R4777	VRS-CZ1JF000J	J 0	1/16W Metal Oxide	AA
R4443	VRS-CZ1JF334J	J 330k	1/16W Metal Oxide	AA	R4778	VRS-CZ1JF104J	J 100k	1/16W Metal Oxide	AA
R4444	VRS-CZ1JF332J	J 3.3k	1/16W Metal Oxide	AA	R4782	VRS-CZ1JF222J	J 2.2k	1/16W Metal Oxide	AA
R4445	VRS-CZ1JF000J	J 0	1/16W Metal Oxide	AA	R4783	VRS-CZ1JF102J	J 1k	1/16W Metal Oxide	AA
R4447	VRS-CZ1JF332J	J 3.3k	1/16W Metal Oxide	AA	R4784	VRS-CZ1JF102J	J 1k	1/16W Metal Oxide	AA
R4448	VRS-CZ1JF101J	J 100	1/16W Metal Oxide	AA	R4785	VRS-CZ1JF102J	J 1k	1/16W Metal Oxide	AA
R4450	VRS-CZ1JF102J	J 1k	1/16W Metal Oxide	AA	R4786	VRS-CZ1JF103J	J 10k	1/16W Metal Oxide	AA
R4498	VRS-CZ1JF101J	J 100	1/16W Metal Oxide	AA	R4787	VRS-CZ1JF103J	J 10k	1/16W Metal Oxide	AA
R4499	VRS-CZ1JF000J	J 0	1/16W Metal Oxide	AA	R4788	VRS-CZ1JF102J	J 1k	1/16W Metal Oxide	AA
R4506	VRS-CZ1JF105J	J 1M	1/16W Metal Oxide	AA	R4789	VRS-CZ1JF102J	J 1k	1/16W Metal Oxide	AA
R4586	VRS-CZ1JF101J	J 100	1/16W Metal Oxide	AA	R4790	VRS-CZ1JF103J	J 10k	1/16W Metal Oxide	AA
R4587	VRS-CZ1JF101J	J 100	1/16W Metal Oxide	AA	R4791	VRS-CZ1JF103J	J 10k	1/16W Metal Oxide	AA
R4588	VRS-CZ1JF000J	J 0	1/16W Metal Oxide	AA	R4792	VRS-CZ1JF102J	J 1k	1/16W Metal Oxide	AA
R4589	VRS-CZ1JF101J	J 100	1/16W Metal Oxide	AA	R4793	VRS-CZ1JF102J	J 1k	1/16W Metal Oxide	AA
					R4794	VRS-CZ1JF103J	J 10k	1/16W Metal Oxide	AA
					R4795	VRS-CZ1JF103J	J 10k	1/16W Metal Oxide	AA
					R4796	VRS-CZ1JF102J	J 1k	1/16W Metal Oxide	AA

Ref. No.	Part No.	★	Description	Code	Ref. No.	Part No.	★	Description	Code
DUNTK2635QA01/00									
VCR PWB UNIT (Continued)									
R4797	VRS-CZ1JF103J	J	10k 1/16W Metal Oxide	AA	R6433	VRS-CZ1JF473J	J	47k 1/16W Metal Oxide	AA
R4798	VRS-CZ1JF103J	J	10k 1/16W Metal Oxide	AA	R6439	VRS-CZ1JF473J	J	47k 1/16W Metal Oxide	AA
R4799	VRS-CZ1JF103J	J	10k 1/16W Metal Oxide	AA	R6446	VRS-CZ1JF104J	J	100k 1/16W Metal Oxide	AA
R5701	VRS-CZ1JF101J	J	100 1/16W Metal Oxide	AA	R6447	VRS-CZ1JF563J	J	56k 1/16W Metal Oxide	AA
R5702	VRS-CZ1JF102J	J	1k 1/16W Metal Oxide	AA	R6448	VRS-CZ1JF473J	J	47k 1/16W Metal Oxide	AA
R5703	VRS-CZ1JF102J	J	1k 1/16W Metal Oxide	AA	R6464	VRS-CZ1JF122J	J	1.2k 1/16W Metal Oxide	AA
R5704	VRK-SA1JF102J	J	1k 1/16W M. Composi.	AB	R6466	VRS-CZ1JF153J	J	15k 1/16W Metal Oxide	AA
R5705	VRK-SA1JF102J	J	1k 1/16W M. Composi.	AB	R6467	VRS-CZ1JF153J	J	15k 1/16W Metal Oxide	AA
R5706	VRK-SA1JF102J	J	1k 1/16W M. Composi.	AB	R6468	VRS-CZ1JF100J	J	10 1/16W Metal Oxide	AA
R5707	VRK-SA1JF102J	J	1k 1/16W M. Composi.	AB	R6469	VRS-CZ1JF104J	J	100k 1/16W Metal Oxide	AA
R5708	VRK-SA1JF102J	J	1k 1/16W M. Composi.	AB	R6470	VRS-CZ1JF224J	J	220k 1/16W Metal Oxide	AA
R5709	VRS-CZ1JF102J	J	1k 1/16W Metal Oxide	AA	R6471	VRS-CZ1JF224J	J	220k 1/16W Metal Oxide	AA
R5710	VRK-SA1JF102J	J	1k 1/16W M. Composi.	AB	R6473	VRS-CZ1JF183J	J	18k 1/16W Metal Oxide	AA
R5711	VRK-SA1JF102J	J	1k 1/16W M. Composi.	AB	R6474	VRS-CZ1JF561J	J	560 1/16W Metal Oxide	AA
R5712	VRS-CZ1JF102J	J	1k 1/16W Metal Oxide	AA	R6475	VRS-CZ1JF561J	J	560 1/16W Metal Oxide	AA
R5713	VRS-CZ1JF102J	J	1k 1/16W Metal Oxide	AA	R6476	VRS-CZ1JF474J	J	470k 1/16W Metal Oxide	AA
R5714	VRK-SA1JF102J	J	1k 1/16W M. Composi.	AB	R6477	VRS-CZ1JF223J	J	22k 1/16W Metal Oxide	AA
R5715	VRS-CZ1JF102J	J	1k 1/16W Metal Oxide	AA	R6479	VRS-CZ1JF474J	J	470k 1/16W Metal Oxide	AA
R5716	VRK-SA1JF102J	J	1k 1/16W M. Composi.	AB	R6480	VRS-CZ1JF473J	J	47k 1/16W Metal Oxide	AA
R5717	VRS-CZ1JF102J	J	1k 1/16W Metal Oxide	AA	R6481	VRS-CZ1JF272J	J	2.7k 1/16W Metal Oxide	AA
R5720	VRS-CZ1JF102J	J	1k 1/16W Metal Oxide	AA	R6482	VRS-CZ1JF103J	J	10k 1/16W Metal Oxide	AA
R5721	VRS-CZ1JF102J	J	1k 1/16W Metal Oxide	AA	R6483	VRS-CZ1JF473J	J	47k 1/16W Metal Oxide	AA
R5722	VRS-CZ1JF102J	J	1k 1/16W Metal Oxide	AA	R6484	VRS-CZ1JF473J	J	47k 1/16W Metal Oxide	AA
R5723	VRK-SA1JF102J	J	1k 1/16W M. Composi.	AB	R6485	VRS-CZ1JF473J	J	47k 1/16W Metal Oxide	AA
R5724	VRS-CZ1JF102J	J	1k 1/16W Metal Oxide	AA	R6486	VRS-CZ1JF473J	J	47k 1/16W Metal Oxide	AA
R5725	VRK-SA1JF102J	J	1k 1/16W M. Composi.	AB	R6487	VRS-CZ1JF000J	J	0 1/16W Metal Oxide	AA
R5732	VRK-SA1JF102J	J	1k 1/16W M. Composi.	AB	R6488	VRS-CZ1JF473J	J	47k 1/16W Metal Oxide	AA
R5740	VRS-CZ1JF102J	J	1k 1/16W Metal Oxide	AA	R6489	VRS-CZ1JF000J	J	0 1/16W Metal Oxide	AA
R5741	VRS-CZ1JF102J	J	1k 1/16W Metal Oxide	AA	R6490	VRS-CZ1JF473J	J	47k 1/16W Metal Oxide	AA
R5742	VRS-CZ1JF102J	J	1k 1/16W Metal Oxide	AA	R6491	VRS-CZ1JF104J	J	100k 1/16W Metal Oxide	AA
R5743	VRS-CZ1JF102J	J	1k 1/16W Metal Oxide	AA	R6492	VRS-CZ1JF104J	J	100k 1/16W Metal Oxide	AA
R5744	VRS-CZ1JF104J	J	100k 1/16W Metal Oxide	AA	R6494	VRS-CZ1JF682J	J	6.8k 1/16W Metal Oxide	AA
R5745	VRS-CZ1JF104J	J	100k 1/16W Metal Oxide	AA	R6495	VRS-CZ1JF473J	J	47k 1/16W Metal Oxide	AA
R5746	VRS-CZ1JF104J	J	100k 1/16W Metal Oxide	AA	R6501	VRS-TV1JD100J	J	10 1/16W Metal Oxide	AA
R5747	VRS-CZ1JF104J	J	100k 1/16W Metal Oxide	AA	R6530	VRS-CZ1JF122J	J	1.2k 1/16W Metal Oxide	AA
R5778	VRS-CY1JF000J	J	0 1/16W Metal Oxide	AA	R6531	VRS-CZ1JF122J	J	1.2k 1/16W Metal Oxide	AA
R5779	VRS-CY1JF000J	J	0 1/16W Metal Oxide	AA	R6532	VRS-CZ1JF331J	J	330 1/16W Metal Oxide	AA
R6402	VRS-CZ1JF102J	J	1k 1/16W Metal Oxide	AA	R6533	VRS-CZ1JF331J	J	330 1/16W Metal Oxide	AA
R6408	VRS-CZ1JF103J	J	10k 1/16W Metal Oxide	AA	R6550	VRS-CZ1JF100J	J	10 1/16W Metal Oxide	AA
R6409	VRS-CZ1JF103J	J	10k 1/16W Metal Oxide	AA	R6551	VRS-CZ1JF153J	J	15k 1/16W Metal Oxide	AA
R6412	VRS-CZ1JF563J	J	56k 1/16W Metal Oxide	AA	R6552	VRS-CZ1JF823J	J	82k 1/16W Metal Oxide	AA
R6413	VRS-CZ1JF153J	J	15k 1/16W Metal Oxide	AA	R6554	VRS-CZ1JF334J	J	330k 1/16W Metal Oxide	AA
R6414	VRS-CZ1JF563J	J	56k 1/16W Metal Oxide	AA	R6555	VRS-CZ1JF154J	J	150k 1/16W Metal Oxide	AA
R6415	VRS-CZ1JF153J	J	15k 1/16W Metal Oxide	AA	R6556	VRS-CZ1JF471J	J	470 1/16W Metal Oxide	AA
R6420	VRS-CY1JF1R0J	J	1 1/16W Metal Oxide	AA	R6557	VRS-CZ1JF105J	J	1M 1/16W Metal Oxide	AA
R6421	VRS-CZ1JF102J	J	1k 1/16W Metal Oxide	AA	R6558	VRS-CZ1JF101J	J	100 1/16W Metal Oxide	AA
R6422	VRS-CZ1JF562J	J	5.6k 1/16W Metal Oxide	AA	R6560	VRK-SA1JF101J	J	100 1/16W M. Composi.	AB
R6423	VRS-CZ1JF562J	J	5.6k 1/16W Metal Oxide	AA	R6561	VRK-SA1JF101J	J	100 1/16W M. Composi.	AB
R6424	VRS-CZ1JF103J	J	10k 1/16W Metal Oxide	AA	R6562	VRS-CZ1JF101J	J	100 1/16W Metal Oxide	AA
R6425	VRS-CY1JF470J	J	47 1/16W Metal Oxide	AA	R6563	VRS-CZ1JF101J	J	100 1/16W Metal Oxide	AA
R6426	VRS-CY1JF470J	J	47 1/16W Metal Oxide	AA	R6564	VRS-CZ1JF101J	J	100 1/16W Metal Oxide	AA
R6427	VRS-CZ1JF102J	J	1k 1/16W Metal Oxide	AA	R6565	VRS-CZ1JF101J	J	100 1/16W Metal Oxide	AA
R6432	VRS-CZ1JF563J	J	56k 1/16W Metal Oxide	AA	R6566	VRS-CZ1JF101J	J	100 1/16W Metal Oxide	AA
					R6567	VRS-CZ1JF101J	J	100 1/16W Metal Oxide	AA
					R6601	VRS-CZ1JF152J	J	1.5k 1/16W Metal Oxide	AA
					R6602	VRS-CZ1JF152J	J	1.5k 1/16W Metal Oxide	AA

Ref. No.	Part No.	★	Description	Code	Ref. No.	Part No.	★	Description	Code
DUNTK2635QA01/00					VCR PWB UNIT (Continued)				
R6603	VRS-CY1JF101J	J	100 1/16W Metal Oxide	AA	FB2447	RBLN-0076TAZZ	J	Ferrite Bead	AC
R6604	VRS-CY1JF101J	J	100 1/16W Metal Oxide	AA	FB4401	RBLN-0057TAZZ	J	Ferrite Bead	AC
R6662	VRS-CY1JF102J	J	1k 1/16W Metal Oxide	AA	FB4410	RBLN-0057TAZZ	J	Ferrite Bead	AC
R6663	VRS-CY1JF102J	J	1k 1/16W Metal Oxide	AA	FB6550	RBLN-0057TAZZ	J	Ferrite Bead	AC
R7732	VRS-CZ1JF101J	J	100 1/16W Metal Oxide	AA	FB6601	RBLN-0056TAZZ	J	Ferrite Bead	AC
R7738	VRS-CZ1JF101J	J	100 1/16W Metal Oxide	AA	P703	QPLGN0363TAZZ	J	Plug 3-pin	AC
R7739	VRS-CZ1JF473J	J	47k 1/16W Metal Oxide	AA	P1401	QPLGN0463TAZZ	J	Plug 4-pin	AC
R7740	VRS-CZ1JF823J	J	82k 1/16W Metal Oxide	AA	P2401	QCNCW6066TAZZ	J	Connecting Wire 60-pin	AK
R7741	VRS-CZ1JF102J	J	1k 1/16W Metal Oxide	AA	P2702	QPLGN1463TAZZ	J	Plug 14-pin	AE
R7742	VRS-CZ1JF102J	J	1k 1/16W Metal Oxide	AA	P6601	QPLGN0463TAZZ	J	Plug 4-pin	AC
R7743	VRS-CZ1JF102J	J	1k 1/16W Metal Oxide	AA	SC705	QSOCN0860TAZZ	J	Socket 8-pin	AE
R7744	VRS-CZ1JF102J	J	1k 1/16W Metal Oxide	AA	SC805	QSOCN2486TAZZ	J	Socket 24-pin	AE
R7745	VRS-CZ1JF823J	J	82k 1/16W Metal Oxide	AA	SC901	QSOCN0786TAZZ	J	Socket 7-pin	AC
R7746	VRS-CZ1JF823J	J	82k 1/16W Metal Oxide	AA	SC902	QSOCN2087TAZZ	J	Socket 20-pin	AE
R7747	VRS-CZ1JF474J	J	470k 1/16W Metal Oxide	AA	SC903	QSOCN1987TAZZ	J	Socket 19-pin	AE
R7748	VRS-CZ1JF474J	J	470k 1/16W Metal Oxide	AA	SC3401	QCNCW8056TAZZ	J	Connecting Wire 80-pin	AP
R7749	VRS-CZ1JF820J	J	82 1/16W Metal Oxide	AA	SLD3	PSLDM3269TAFW	J	VCR Shield-A	AD
R7750	VRS-CZ1JF103J	J	10k 1/16W Metal Oxide	AA	SLD4	PSLDM3270TAFW	J	VCR Shield-B	AD
R7751	VRS-CZ1JF474J	J	470k 1/16W Metal Oxide	AA		PSLDM9087TAZZ	J	Shield (29 X 39 mm)	AC
R7752	VRS-CZ1JF474J	J	470k 1/16W Metal Oxide	AA		PSLDM9092TAZZ	J	Shield (32 X 45 mm)	AB
R7753	VRS-CZ1JF823J	J	82k 1/16W Metal Oxide	AA		PSHEG0015TAZZ	J	Radiator Sheet, x1 (13 X 13 t1.3)	AG
R7754	VRS-CZ1JF102J	J	1k 1/16W Metal Oxide	AA		PSHEG0022TAZZ	J	Radiator Sheet, x2 (15 X 15 t1.0)	AE
R7755	VRS-CZ1JF102J	J	1k 1/16W Metal Oxide	AA		PMLT-0126TAZZ	J	Spacer	AB
R7756	VRS-CZ1JF102J	J	1k 1/16W Metal Oxide	AA					
R7758	VRS-CZ1JF823J	J	82k 1/16W Metal Oxide	AA					

MISCELLANEOUS PARTS

FB401	RBLN-0057TAZZ	J	Ferrite Bead	AC
FB404	RBLN-0057TAZZ	J	Ferrite Bead	AC
FB407	RBLN-0057TAZZ	J	Ferrite Bead	AC
FB408	RBLN-0057TAZZ	J	Ferrite Bead	AC
FB810	RBLN-0028TAZZ	J	Ferrite Bead	AB
FB812	RBLN-0028TAZZ	J	Ferrite Bead	AB
FB901	RBLN-0057TAZZ	J	Ferrite Bead	AC
FB902	RBLN-0057TAZZ	J	Ferrite Bead	AC
FB905	RBLN-0057TAZZ	J	Ferrite Bead	AC
FB906	RBLN-0057TAZZ	J	Ferrite Bead	AC
FB908	RBLN-0057TAZZ	J	Ferrite Bead	AC
FB2408	RBLN-0076TAZZ	J	Ferrite Bead	AC
FB2409	RBLN-0076TAZZ	J	Ferrite Bead	AC
FB2410	RBLN-0076TAZZ	J	Ferrite Bead	AC
FB2411	RBLN-0076TAZZ	J	Ferrite Bead	AC
FB2412	RBLN-0076TAZZ	J	Ferrite Bead	AC
FB2413	RBLN-0076TAZZ	J	Ferrite Bead	AC
FB2414	RBLN-0076TAZZ	J	Ferrite Bead	AC
FB2415	RBLN-0076TAZZ	J	Ferrite Bead	AC
FB2417	RBLN-0076TAZZ	J	Ferrite Bead	AC
FB2418	RBLN-0076TAZZ	J	Ferrite Bead	AC
FB2419	RBLN-0076TAZZ	J	Ferrite Bead	AC
FB2421	RBLN-0076TAZZ	J	Ferrite Bead	AC
FB2423	RBLN-0076TAZZ	J	Ferrite Bead	AC
FB2425	RBLN-0076TAZZ	J	Ferrite Bead	AC
FB2442	RBLN-0076TAZZ	J	Ferrite Bead	AC

**OSD HD GENERATOR UNIT
(IN VCR PWB UNIT)****INTEGRATED CIRCUIT**

IC4601	VHIBA7046F/-1	J	Sync. Sep. HD Generator	AF
--------	---------------	---	-------------------------	----

CAPACITORS

C4601	VCKYCY1AF105Z	J	1 10V Ceramic	AC
C4602	VCSATA1AJ106M	J	10 10V Tantalum	AC
C4603	VCKYCY1EF223Z	J	0.022 25V Ceramic	AB
C4604	VCSAPD1CJ105M	J	1 16V Tantalum	AC
C4605	VCKYCY1HB222K	J	2200p 50V Ceramic	AB
C4606	VCCCCZ1HH101J	J	100p 50V Ceramic	AB

RESISTORS

R4601	VRS-CY1JF330J	J	33 1/16W Metal Oxide	AA
R4602	VRS-CZ1JF474J	J	470k 1/16W Metal Oxide	AA
R4603	VRS-CZ1JF103J	J	10k 1/16W Metal Oxide	AA
R4604	VRS-CZ1JF474J	J	470k 1/16W Metal Oxide	AA
R4605	VRS-CZ1JF124F	J	120k 1/16W Metal Oxide	AB
R4606	VRS-CZ1JF103F	J	10k 1/16W Metal Oxide	AB
R4607	VRS-CZ1JF102J	J	1k 1/16W Metal Oxide	AA
R4608	VRS-CZ1JF272J	J	2.7k 1/16W Metal Oxide	AA

Ref. No.	Part No.	★	Description	Code	Ref. No.	Part No.	★	Description	Code
RAMP-0015TAN0 HEAD AMP. PWB UNIT									
INTEGRATED CIRCUITS									
IC301	VHIBH7272KV-1	J	PRE/REC AMP	BC	C381	VCKYCY1HB102K	J	1000p 50V Ceramic	AA
IC303	VHiXL93L46F-1	J	EEPROM	AG	C382	VCKYCY1HB102K	J	1000p 50V Ceramic	AA
TRANSISTORS									
Q301	VS2SC4738Y/-1	J	Buffer	AA	C383	VCSATE0JJ476M	J	47 6.3V Tantalum	AF
Q302	VS2SC4738Y/-1	J	Buffer	AA	C384	VCSATE0JJ476M	J	47 6.3V Tantalum	AF
Q305	VS2SC4738Y/-1	J	Switch	AA	RESISTORS				
Q306	VS2SC4738Y/-1	J	Switch	AA	R301	VRS-CY1JF100J	J	10 1/16W Metal Oxide	AA
Q307	VS2SC4738Y/-1	J	Switch	AA	R302	VRS-CY1JF331J	J	330 1/16W Metal Oxide	AA
Q309	VSDTC114EE/-1	J	Switch	AB	R303	VRS-CY1JF331J	J	330 1/16W Metal Oxide	AA
DIODE					R308	VRS-CY1JF331J	J	330 1/16W Metal Oxide	AA
D301	VHDMA2S111/-1	J	Diode MA2S111	AC	R309	VRS-CY1JF331J	J	330 1/16W Metal Oxide	AA
COILS					R310	VRS-CY1JF100J	J	10 1/16W Metal Oxide	AA
L302	VP-NM4R7MR23N	J	Peaking Coil 4.7μH	AD	R311	VRS-CY1JF223J	J	22k 1/16W Metal Oxide	AA
L304	VP-NM4R7MR23N	J	Peaking Coil 4.7μH	AD	R313	VRS-CY1JF273J	J	27k 1/16W Metal Oxide	AA
L305	VP-NM4R7MR23N	J	Peaking Coil 4.7μH	AD	R316	VRS-CY1JF222J	J	2.2k 1/16W Metal Oxide	AA
L306	VP-NM4R7MR23N	J	Peaking Coil 4.7μH	AD	R317	VRS-CY1JF332J	J	3.3k 1/16W Metal Oxide	AA
CAPACITORS					R318	VRS-CY1JF103J	J	10k 1/16W Metal Oxide	AA
C301	VCKYCY1HB102K	J	1000p 50V Ceramic	AA	R319	VRS-CY1JF472J	J	4.7k 1/16W Metal Oxide	AA
C302	VCKYCY1HB102K	J	1000p 50V Ceramic	AA	R323	VRS-CY1JF472J	J	4.7k 1/16W Metal Oxide	AA
C304	VCKYCY1HF103Z	J	0.01 50V Ceramic	AA	R324	VRS-CY1JF102J	J	1k 1/16W Metal Oxide	AA
C306	VCKYCY1HF103Z	J	0.01 50V Ceramic	AA	R325	VRS-CY1JF101J	J	100 1/16W Metal Oxide	AA
C309	VCKYCY1HF103Z	J	0.01 50V Ceramic	AA	R326	VRS-CY1JF223J	J	22k 1/16W Metal Oxide	AA
C310	VCKYCY1HF103Z	J	0.01 50V Ceramic	AA	R327	VRS-CY1JF682J	J	6.8k 1/16W Metal Oxide	AA
C311	VCKYCY1HB102K	J	1000p 50V Ceramic	AA	R329	VRS-CY1JF102J	J	1k 1/16W Metal Oxide	AA
C314	VCKYCY1HB102K	J	1000p 50V Ceramic	AA	R331	VRS-CY1JF101J	J	100 1/16W Metal Oxide	AA
C316	VCKYCY1HF103Z	J	0.01 50V Ceramic	AA	R332	VRS-CY1JF102J	J	1k 1/16W Metal Oxide	AA
C317	VCSATE1AJ336M	J	33 10V Tantalum	AG	R333	VRS-CY1JF101J	J	100 1/16W Metal Oxide	AA
C318	VCKYCY1CF104Z	J	0.1 16V Ceramic	AA	R334	VRS-CY1JF222J	J	2.2k 1/16W Metal Oxide	AA
C319	VCKYCY1HF103Z	J	0.01 50V Ceramic	AA	R336	VRS-CY1JF273J	J	27k 1/16W Metal Oxide	AA
C320	VCSATA1AJ106M	J	10 10V Tantalum	AC	R338	VRS-CY1JF223J	J	22k 1/16W Metal Oxide	AA
C321	VCKYCY1HF103Z	J	0.01 50V Ceramic	AA	R361	VRS-CY1JF102J	J	1k 1/16W Metal Oxide	AA
C325	VCKYCY1CF104Z	J	0.1 16V Ceramic	AA	R362	VRS-CY1JF103J	J	10k 1/16W Metal Oxide	AA
C326	VCKYCY1AF105Z	J	1 10V Ceramic	AC	R363	VRS-CY1JF392J	J	3.9k 1/16W Metal Oxide	AA
C327	VCKYCY1AF105Z	J	1 10V Ceramic	AC	R364	VRS-CY1JF103J	J	10k 1/16W Metal Oxide	AA
C328	VCSATA1AJ106M	J	10 10V Tantalum	AC	R365	VRS-CY1JF392J	J	3.9k 1/16W Metal Oxide	AA
C329	VCKYCY1HF103Z	J	0.01 50V Ceramic	AA	R366	VRS-CY1JF103J	J	10k 1/16W Metal Oxide	AA
C330	VCKYCY1HB222K	J	2200p 50V Ceramic	AA	R370	VRS-CY1JF562J	J	5.6k 1/16W Metal Oxide	AA
C331	VCKYCY1HB222K	J	2200p 50V Ceramic	AA	R371	VRS-CY1JF562J	J	5.6k 1/16W Metal Oxide	AA
C332	VCSATA1AJ106M	J	10 10V Tantalum	AC	R372	VRS-CY1JF473J	J	47k 1/16W Metal Oxide	AA
C334	VCKYCY1HF103Z	J	0.01 50V Ceramic	AA	R373	VRS-CY1JF562J	J	5.6k 1/16W Metal Oxide	AA
C335	VCKYCY1HF103Z	J	0.01 50V Ceramic	AA	R374	VRS-CY1JF222J	J	2.2k 1/16W Metal Oxide	AA
C344	VCKYCY1HF103Z	J	0.01 50V Ceramic	AA	R375	VRS-CY1JF102J	J	1k 1/16W Metal Oxide	AA
C345	VCSATA1AJ106M	J	10μF 10V Tantalum	AC	R376	VRS-CY1JF222J	J	2.2k 1/16W Metal Oxide	AA
C348	VCKYCY1EB223K	J	0.022 25V Ceramic	AA	R377	VRS-TV1JD2R2J	J	2.2 1/16W Metal Oxide	AA
C353	VCKYCY1HB102K	J	1000p 50V Ceramic	AA	MISCELLANEOUS PARTS				
C354	VCKYCY1HF103Z	J	0.01 50V Ceramic	AA	P306	QCNCM8056TAZZ	J	Connector 80-pin	AQ
C355	VCSATD0JJ227M	J	220 6.3V Tantalum	AH	SC301	QSOCN0665TAZZ	J	Socket 6-pin	AD
C357	VCKYCY1HB472K	J	4700p 50V Ceramic	AA	SC302	QSOCN2066TAZZ	J	Socket 20-pin	AE
C380	VCKYCY1HB102K	J	1000p 50V Ceramic	AA	SC303	QSOCN0766TAZZ	J	Socket 7-pin	AD
					SC304	QSOCN0966TAZZ	J	Socket 9-pin	AF
					SC305	QSOCN1865TAZZ	J	Socket 18-pin	AE
					SC307	QSOCN0666TAZZ	J	Socket 6-pin	AD
					TP302	QLUGP0111TAFW	J	Lug Test Point	AA
					TP303	QLUGP0111TAFW	J	Lug Test Point	AA
						QCNCW-1447TAZZ	J	Grounding Wire	AH

Ref. No.	Part No.	★	Description	Code	Ref. No.	Part No.	★	Description	Code
RAMP-0016TANO					RESISTORS				
MICROPHONE AMP. PWB UNIT									
INTEGRATED CIRCUITS									
IC6601	VHiLA7471M/-1	J		AN	R6406	VRS-CZ1JF333J	J	33k 1/16W Metal Oxide	AA
IC6602	VHiBA3308FV-1	J		AH	R6451	VRS-CZ1JF272J	J	2.7k 1/16W Metal Oxide	AA
TRANSISTORS									
Q6454	VSUMX2/////1	J	UMX2	AB	R6452	VRS-CZ1JF272J	J	2.7k 1/16W Metal Oxide	AA
Q6601	VS2SC4617B/-1	J	2SC4617B	AA	R6453	VRS-CZ1JF153J	J	15k 1/16W Metal Oxide	AA
COIL									
L6601	VPABM101J160N	J	Coil 100μH	AC	R6454	VRS-CZ1JF153J	J	15k 1/16W Metal Oxide	AA
CAPACITORS									
C6412	VCKYTV1CF225Z	J	2.2 16V Ceramic	AC	R6455	VRS-CZ1JF471J	J	470 1/16W Metal Oxide	AA
C6413	VCKYTV1CF225Z	J	2.2 16V Ceramic	AC	R6456	VRS-CZ1JF471J	J	470 1/16W Metal Oxide	AA
C6453	VCSAPD1CJ105M	J	1 16V Tantalum	AC	R6457	VRS-CZ1JF185J	J	1.8M 1/16W Metal Oxide	AA
C6454	VCSAPD0JJ225M	J	2.2 6.3V Tantalum	AD	R6458	VRS-CZ1JF473J	J	47k 1/16W Metal Oxide	AA
C6455	VCSAPD0JJ225M	J	2.2 6.3V Tantalum	AD	R6497	VRS-CZ1JF104J	J	100k 1/16W Metal Oxide	AA
C6458	VCSATA0JJ685M	J	6.8 6.3V Tantalum	AD	R6498	VRS-CZ1JF472J	J	4.7k 1/16W Metal Oxide	AA
C6603	VCKYCY1CF104Z	J	0.1 16V Ceramic	AA	R6603	VRS-CZ1JF332F	J	3.3k 1/16W Metal Oxide	AA
C6604	VCKYTQ1CB105K	J	1 16V Ceramic	AC	R6604	VRS-CY1JF113F	J	11k 1/16W Metal Oxide	AA
C6605	VCKYCY1CB333K	J	0.033 16V Ceramic	AA	R6605	VRS-CZ1JF822J	J	8.2k 1/16W Metal Oxide	AA
C6607	VCKYTQ1HB104K	J	0.1 50V Ceramic	AB	R6606	VRS-CY1JF103F	J	10k 1/16W Metal Oxide	AA
C6608	VCSATA0JJ106M	J	10 6.3V Tantalum	AD	R6607	VRS-CZ1JF153J	J	15k 1/16W Metal Oxide	AA
C6610	VCKYTQ1HB104K	J	0.1 50V Ceramic	AB	R6608	VRS-CZ1JF393J	J	39k 1/16W Metal Oxide	AB
C6611	VCKYCY1CB473K	J	0.047 16V Ceramic	AA	R6609	VRS-CZ1JF333J	J	33k 1/16W Metal Oxide	AA
C6612	VCKYCY1EB223K	J	0.022 25V Ceramic	AA	R6610	VRS-CZ1JF332F	J	3.3k 1/16W Metal Oxide	AA
C6613	VCKYCY1HB123K	J	0.012 50V Ceramic	AB	R6611	VRS-CZ1JF103F	J	10k 1/16W Metal Oxide	AB
C6614	VCKYCY1CB473K	J	0.047 16V Ceramic	AA	R6612	VRS-CY1JF113F	J	11k 1/16W Metal Oxide	AA
C6615	VCKYCY1HB153K	J	0.015 50V Ceramic	AA	R6613	VRS-CZ1JF153J	J	15k 1/16W Metal Oxide	AA
C6616	VCKYCY1HB153K	J	0.015 50V Ceramic	AA	R6614	VRS-CZ1JF822J	J	8.2k 1/16W Metal Oxide	AA
C6617	VCKYCZ1HB471K	J	470p 50V Ceramic	AB	R6615	VRS-CZ1JF393J	J	39k 1/16W Metal Oxide	AB
C6618	VCKYTQ1CB105K	J	1 16V Ceramic	AC	R6616	VRS-CZ1JF105J	J	1M 1/16W Metal Oxide	AA
C6619	VCKYCY1CB333K	J	0.033 16V Ceramic	AA	R6617	VRS-CZ1JF154J	J	150k 1/16W Metal Oxide	AA
C6620	VCKYCY1CB473K	J	0.047 16V Ceramic	AA	R6618	VRS-CZ1JF473J	J	47k 1/16W Metal Oxide	AA
C6621	VCKYCY1HB123K	J	0.012 50V Ceramic	AB	R6619	VRS-CZ1JF333J	J	33k 1/16W Metal Oxide	AA
C6622	VCKYCY1EB223K	J	0.022 25V Ceramic	AA	R6620	VRS-CZ1JF102J	J	1k 1/16W Metal Oxide	AA
C6623	VCKYCY1CB473K	J	0.047 16V Ceramic	AA	R6621	VRS-CZ1JF154J	J	150k 1/16W Metal Oxide	AA
C6624	VCKYCY1HB153K	J	0.015 50V Ceramic	AA	R6625	VRS-CZ1JF154J	J	150k 1/16W Metal Oxide	AA
C6625	VCKYCY1HB153K	J	0.015 50V Ceramic	AA	R6626	VRS-CZ1JF472J	J	4.7k 1/16W Metal Oxide	AA
C6626	VCKYCZ1HB471K	J	470p 50V Ceramic	AB	R6627	VRS-CZ1JF473J	J	47k 1/16W Metal Oxide	AA
C6627	VCSAPD1AJ225M	J	2.2 10V Tantalum	AC	R6650	VRS-CY1JF000J	J	0 1/16W Metal Oxide	AA
C6628	VCSATA1AJ106M	J	10 10V Tantalum	AC	R6651	VRS-CY1JF000J	J	0 1/16W Metal Oxide	AA
C6629	VCKYCY1EB103K	J	0.01 25V Ceramic	AA	R6652	VRS-CY1JF273J	J	27k 1/16W Metal Oxide	AA
C6630	VCKYCY1EB103K	J	0.01 25V Ceramic	AA	R6653	VRS-CY1JF273J	J	27k 1/16W Metal Oxide	AA
C6631	VCKYCZ1AF104Z	J	0.1 10V Ceramic	AB	R6654	VRS-CY1JF000J	J	0 1/16W Metal Oxide	AA
C6632	VCKYCY1EB103K	J	0.01 25V Ceramic	AA	MISCELLANEOUS PARTS				
C6633	VCSATA1AJ106M	J	10 10V Tantalum	AC	SC6601	QSOCN1587TAZZ	J	Socket 15-pin	AD
C6658	VCKYCZ1AF104Z	J	0.1 10V Ceramic	AB					
C6696	VCKYCY1HB102K	J	1000p 50V Ceramic	AA					
C6697	VCKYCY1HB102K	J	1000p 50V Ceramic	AA					

Ref. No.	Part No.	★	Description	Code
RCCD-0008TAN2				
CCD PWB UNIT				
TRANSISTOR				
Q1	VS2SK508///-1	J	Buffer	AE
DIODE				
D1	VHDDA121///-1	J	Diode DA121	AA
CAPACITORS				
C1	VCKYTQ1CF225Z	J	2.2 16V Ceramic	AB
C2	VCKYCY1HF103Z	J	0.01 50V Ceramic	AA
C3	VCSATE1VJ335M	J	3.3 35V Tantalum	AD
C4	VCCCCY1HH221J	J	220p 50V Ceramic	AA
C5	VCKYCY1HB102K	J	1000p50V Ceramic	AA
C6	VCKYTV1CF105Z	J	1 16V Ceramic	AB
C7	VCKYTV1EB104K	J	0.1 25V Ceramic	AB
RESISTORS				
R2	VRS-CY1JF101J	J	100 1/16W Metal Oxide	AA
R3	VRS-CY1JF392J	J	3.9k 1/16W Metal Oxide	AA
R5	VRS-CY1JF473J	J	47k 1/16W Metal Oxide	AA
R6	VRS-CY1JF105J	J	1M 1/16W Metal Oxide	AA
R7	VRS-CY1JF222J	J	2.2k 1/16W Metal Oxide	AA
R8	VRS-CY1JF105J	J	1M 1/16W Metal Oxide	AA

Ref. No.	Part No.	★	Description	Code
LENS UNIT PARTS				
12	CLNS-0124HA06	J	Lens Unit Ass'y	CB
12-1	CLNSA0124TA01	J	Lens Unit	BU
12-1-1	VHi24LC4BiN-1	J	IC EEPROM	AL
12-1-2	99JBCA307A015	J	Focus Motor Ass'y	AY
12-1-3	99JBCA307A010	J	Zoom Motor Ass'y	AY
12-1-4	99JBCA109A012	J	Front Group Frame Rubber	AD
12-1-5	99JDH170351FB	J	Screw (B)	AB
12-2	PFiLW0062TAZZ	J	Crystal Filter	AU
12-3	PCOVM8019TA00	J	Dust Proof Rubber	AC
12-4	VHiLZ2463A6-1	J	CCD Sensor	BM
12-5	LANGK0314TAFW	J	CCD Fitting Angle	AC
12-6	Not Available	-	CCD PWB Unit	-
12-7	LX-HZ0013TAFF	J	Screw 1.7x6, x2	AA

**LENS UNIT EXPLOD VIEW /
EXPLOSIONSDARSTELLUNG DER OBJEKTIVEINHEIT
摄影装置的分解图**

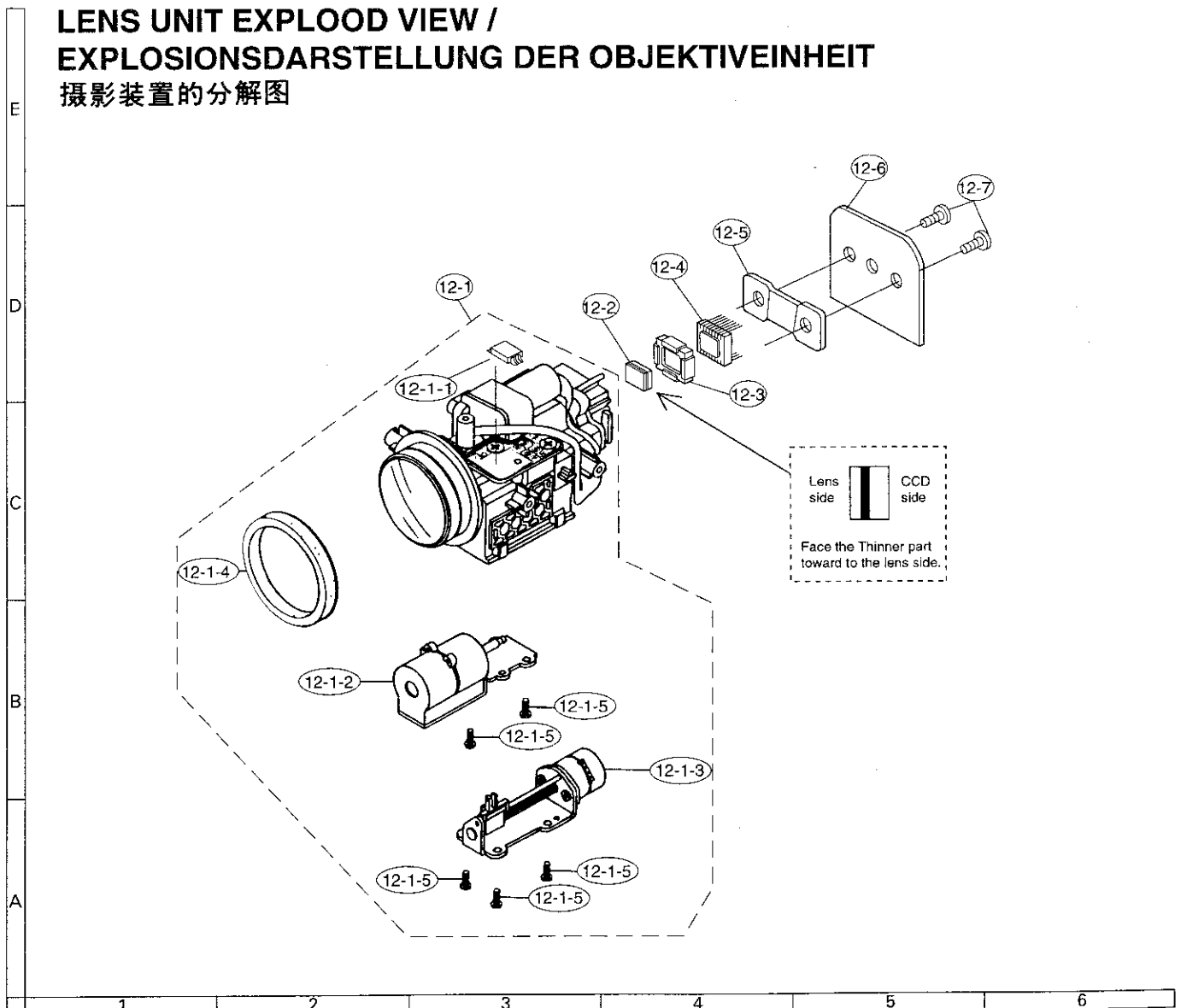

Ref. No.	Part No.	★	Description	Code	Ref. No.	Part No.	★	Description	Code
CABINET PARTS									
1	<i>Not Available</i>	—	VCR Frame Ass'y with Switch/Batt. Terminal	—	4-2	<i>Not Used</i>			
1-1	DCABA6141TAK5	J	VCR Frame Ass'y	AW	4-3	QSW-Z0223TAZZ	J	Power Switch Unit	AN
1-1-1	<i>Not Available</i>	—	VCR Frame	—	4-4	QSW-Z0229TAZZ	J	Zoom Switch Unit	AP
1-1-2	JKNBP0114TASA	J	Batt. Lock Knob	AD	5	<i>Not Available</i>	—	Tilt Angle Unit Ass'y	—
1-1-3	LANGK0323TA00	J	Lid Lock Receive Angle	AD	5-1	DANGF0317TA01	J	Tilt Angle Unit	AU
1-1-4	LHLDZ1337TAZZ	J	Batt. Lock Holder	AD	5-1-1	GDAi-1046TASA	J	Rotation Axle	AF
1-1-5	<i>Not Used</i>				5-1-2	<i>Not Available</i>	—	Tilt Frame-V	—
1-1-6	<i>Not Used</i>				5-1-3	LANGF0318TAFW	J	Tilt Frame-C	AH
1-1-7	LX-NZ0076TAFW	J	Nut	AB	5-1-4	LANGH0062TAFW	J	Positioning Plate	AD
1-1-8	MLEVP0018TAZZ	J	Eject Lever	AD	5-1-5	PSPAZ0116TAZZ	J	Rotating Spacer	AE
1-1-9	MSPRC0071TAFJ	J	Batt. Push-out Spring	AC	5-1-6	PSPAZ0117TAZZ	J	Tilt Spacer	AF
1-1-10	MSPRC0075TAFJ	J	Batt. Lock Spring	AD	5-1-7	LX-HZ0017TAFW	J	Screw M2x8	AA
1-1-11	MSPRP0147TAFJ	J	Batt. Intermediate Lock Spring	AC	5-2	LHLDW1034TAZZ	J	Tilt FPC Holder	AE
1-1-12	PDMPF1007TAZZ	J	Damper	AF	5-3	QPWBH2636TAZZ	J	Tilt FPC	AV
1-1-13	PSHEP0037TAZZ	J	Shielding Sheet	AB	6	CCOVA1381TAK1	J	Tilt Cover Ass'y	AM
1-1-14	PSPAG0077TA00	J	Floating Gum	AA	6-1	GCOVA1381TAKA	J	Tilt Cover	AK
1-1-15	PSPAG0079TAZZ	J	Cushion	AD	6-2	GCOVH1175TASA	J	DC Cable Hole Cover	AD
1-1-16	TLABH0251TAZZ	J	Caution Label	AC	7	CDAi-1053TA01	J	Tripod Base Ass'y	AS
1-2	QSW-Z0224TAZZ	J	Reverse/Eject Switch	AP	7-1	<i>Not Available</i>	—	Tripod Base	—
1-3	QTANZ0108TAZZ	J	Batt. Terminal Unit	AP	7-2	LANGF0321TAFW	J	Tripod Screw Cover	AD
2	CCABB6151TAK1	J	LCD Cabinet Ass'y	AY	7-3	PSPAG0078TA00	J	Rubber Spacer	AB
2-1	<i>Not Available</i>	—	LCD Cabinet	—	8	<i>Not Available</i>	—	VCR Lid Ass'y with Microphone	—
2-2	GCOVA1383TAZZ	J	R/C Receiver Cover	AB	8-1	DFTAC1228TAK2	J	VCR Lid Ass'y	BC
2-3	GCOVA1384TAZZ	J	LED Cover	AB	8-1-1	<i>Not Available</i>	—	VCR Lid	—
2-4	GFTAS1010TASA	J	Lamp Compartment Cover	AD	8-1-2	GCOVA1379TAKA	J	Grip Cover	AK
2-5	HBDGB0044TASA	J	SHARP Badge	AF	8-1-3	GCOVA1380TASA	J	Batt. Lid Cover	AC
2-6	JBTN-0249TASA	J	GUI Button	AC	8-1-4	GFTAB1053TASA	J	Batt. Lid	AF
2-7	LX-NZ0076TAFW	J	Nut	AB	8-1-5	HBDGS0072TASA	J	DV Badge	AF
2-8	PSHEM0001TAZZ	J	Aluminium Sheet	AD	8-1-6	HDEC0235TASA	J	Microphone Grille	AN
2-9	QEARP0193TAZZ	J	LCD Grounding Sheet	AF	8-1-7	JKNBP0111TASA	J	Open Knob	AB
2-10	TLABH0217TAZZ	J	Facing Recording Label	AC	8-1-8	JKNBP0112TASA	J	Batt. Lid Knob-A	AD
2-11	TLABH0247TAZZ	J	Lamp Compartment Label	AB	8-1-9	JKNBP0113TASA	J	Batt. Lid Knob-B	AD
3	CCABC6068TAK1	J	Camera Front Cabinet Ass'y	BA	8-1-10	LANGK0322TA00	J	Batt. Lid Lock Angle	AE
3-1	<i>Not Available</i>	—	Camera Front Cabinet	—	8-1-11	LHLDZ1330TAZZ	J	Batt. Lid Lock	AB
3-2	GCOVH9123TASA	J	Lens Protection Cover	AR	8-1-12	LHLDZ1331TAZZ	J	Lid Lock Holder	AC
3-3	GCOVH9124TASA	J	Lens Decoration Cover	AM	8-1-13	LSTYM0011TAFW	J	Stay	AD
3-4	TLABH0246TAZZ	J	Lithium Batt. Compartment Label	AC	8-1-14	<i>Not Used</i>			
4	<i>Not Available</i>	—	Camera Rear Cabinet Ass'y with Switch Unit	—	8-1-15	MSPRD0042TAFJ	J	VCR Lid Spring	AC
4-1	DCABD6068TAK1	J	Camera Rear Cabinet Ass'y	AX	8-1-16	MSPRP0146TAFJ	J	Batt. Lid Lock Spring	AC
4-1-1	<i>Not Available</i>	—	Camera Rear Cabinet	—	8-1-17	MSPRT0032TAFJ	J	Lid Lock Spring	AB
4-1-2	JBTN-0246TASA	J	Camera Control Button	AD	8-1-18	NGERH3002TAFW	J	Damper Gear	AE
4-1-3	JBTN-0247TASA	J	Power Lock Button	AF	8-1-19	NSFTZ0055TAFW	J	Batt. Lid Lock Knob Shaft	AC
4-1-4	JKNBP0108TASA	J	Power Knob	AC	8-1-20	NSFTZ0057TAFW	J	VCR Lid Shaft	AD
4-1-5	LHLDZ1311TAZZ	J	Power Knob Holder	AE	8-1-21	PFLT-0011TAZZ	J	Felt	AA
4-1-6	LHLDZ1312TAZZ	J	Power Lock Button Holder	AD	8-1-22	PSHEP0040TAZZ	J	Protection Sheet	AC
4-1-7	MSPRC0070TAFJ	J	Power Lock Button Spring	AB	8-1-23	PSPAG0068TAZZ	J	Batt. Fitting Rubber	AA
					8-1-24	PSPAG0079TAZZ	J	Lid Cushion	AD
					8-1-25	TLABH0253TAZZ	J	Batt. Label	AC
					8-1-26	<i>Not Used</i>			
					8-1-27	PSPAZ0115TAZZ	J	Spacer	AC
					8-2	LHLDZ1333TAZZ	J	Microphone Holder	AC

Ref. No.	Part No.	★	Description	Code	Ref. No.	Part No.	★	Description	Code
CABINET PARTS					a	LX-BZ0175TAFF	J	Screw M1.7, x2	AA
(Continued)					b	LX-BZ0190TAFF	J	Screw M2 Special, x1	AC
8-3	<i>Not Used</i>				c	LX-BZ0192TAFF	J	Screw M1.7 Floating, x2	AB
8-4	<i>Not Used</i>				d	LX-HZ0018TAFF	J	Screw M2x6 Tapping, x28	AA
8-5	PMLT-0116TAZZ	J	Sound Shield Sheet	AC	e	LX-HZ0031TAFF	J	Screw M2x4 Tapping, x23	AA
8-6	QEARP0192TAZZ	J	Mic. Shield	AC	f	XBPSD26P08J00	J	Screw M2.6x8 with Washer, x2	AA
8-7	RMiCC0067TAZZ	J	Microphone Unit	AU	g	XiPSF20P03000	J	Screw M2x3, x23	AA
9	CHLDZ1334TA01	J	LCD Holder Ass'y	AH					
9-1	<i>Not Available</i>	—	LCD Holder	—					
9-2	PSHEP0038TAZZ	J	Light Shield Plate	AB					
9-3	PTPEH0001TAZZ	J	LCD Fitting Tape	AB					
10	CPNLC0019RM01	J	LCD Panel Ass'y	CE					
10-1	<i>Not Available</i>	—	LCD Panel	—					
10-2	<i>Not Available</i>	—	Cover AR Coat	—					
11	CCOVA1378TAK1	J	Side Cover Ass'y	AX					
11-1	<i>Not Available</i>	—	Side Cover	—					
11-2	LHLDW1070GEZZ	J	Wire Holder	AA					
11-3	LHLDZ1313TAZZ	J	Speaker Holder	AE					
11-4	LHLDZ1329TAZZ	J	Lens Holder	AD					
11-5	<i>Not Used</i>								
11-6	PCOVP9049TAZZ	J	Speaker Mesh	AC					
11-7	RUNTK0311TAZZ	J	Lithium Batt. Terminal	AM					
11-8	VSP0028P-368N	J	Speaker	AM					
13	CFTAC1226TA01	J	Cassette Control Lid Ass'y	AG					
13-1	<i>Not Available</i>	—	Cassette Control Lid	—					
13-2	PCOVP9051TA00	J	Cassette Control Cover	AC					
14	<i>Not Available</i>	—	Camera PWB Unit	—					
15	<i>Not Available</i>	—	VCR PWB Unit	—					
16	KLMPV0018TAZZ	J	Fluorescent Lamp Unit	AZ					
17	PZETV0341TAZZ	J	Lamp Shield Plate	AF					
18	RINV-0017TAZZ	J	Inverter Unit	AY					
19	MSPRP0148TAFJ	J	Light Guide Set Spring	AD					
20	PMiR-0017TAZZ	J	Reflection Sheet	AE					
21	PGiDM0022TAZZ	J	Light Guide Plate	AK					
22	PSHEP0024TAZZ	J	Diffusion Sheet	AF					
23	PSHEP0022TAZZ	J	Prism Sheet	AM					
24	PZETV0324TAZZ	J	LCD Fitting Sheet	AB					
25	GCOVH1184TAZZ	J	Terminal Cover	AD					
26	LHLDB1018TASA	J	Lithium Batt. Holder	AD					
27	TLABM1658TAZZ	J	Model Label (VL-DC1E)	AC					
27	TLABM1657TAZZ	J	Model Label (VL-DC1H)	AC					
27	TLABM1656TAZZ	J	Model Label (VL-DC1S)	AC					
28	<i>Not Available</i>	—	Mechanism Chassis Ass'y	—					
29	<i>Not Used</i>								
30	QSW-Z0219TAZZ	J	Switch	AP					
31	QTANZ0109TAZZ	J	Terminal 60-pin	BD					

MECHANISM CHASSIS PARTS / TEILE DER CHASSIS-MECHA

机芯底盘零件

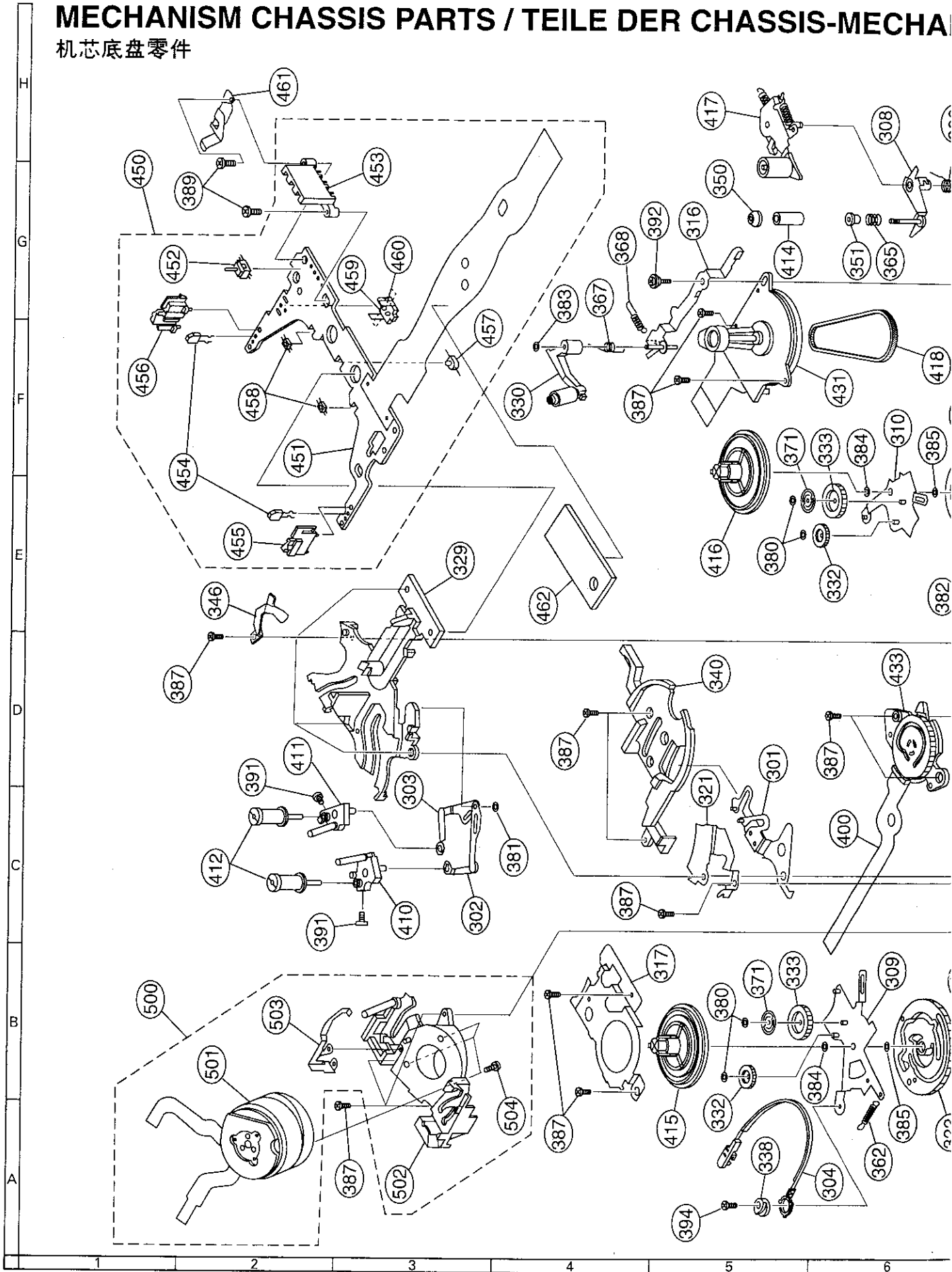

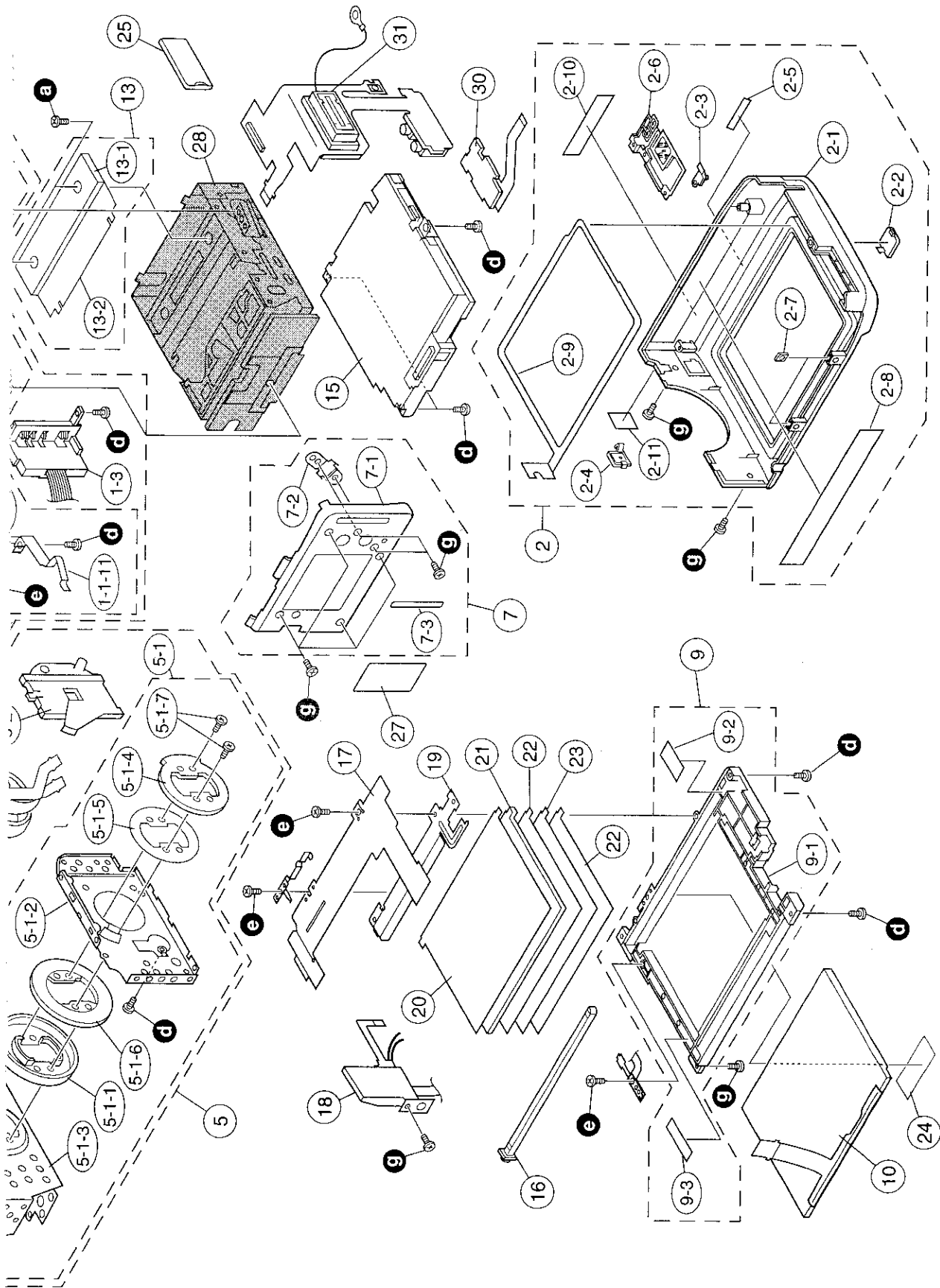

7	8	9	10	11	12
---	---	---	----	----	----

IIIK

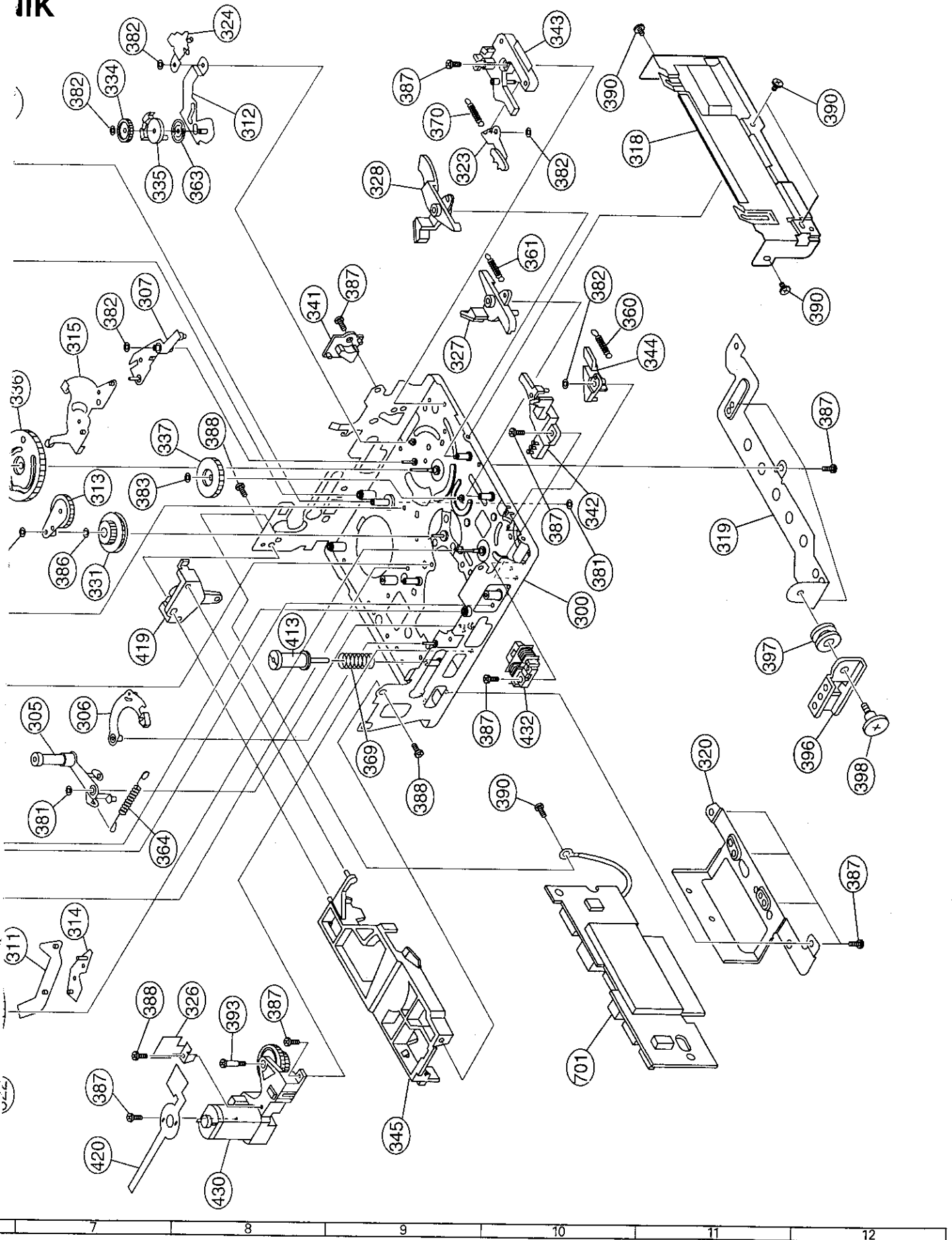

CABINET PARTS / GEHÄUSETEILE 壳体零件

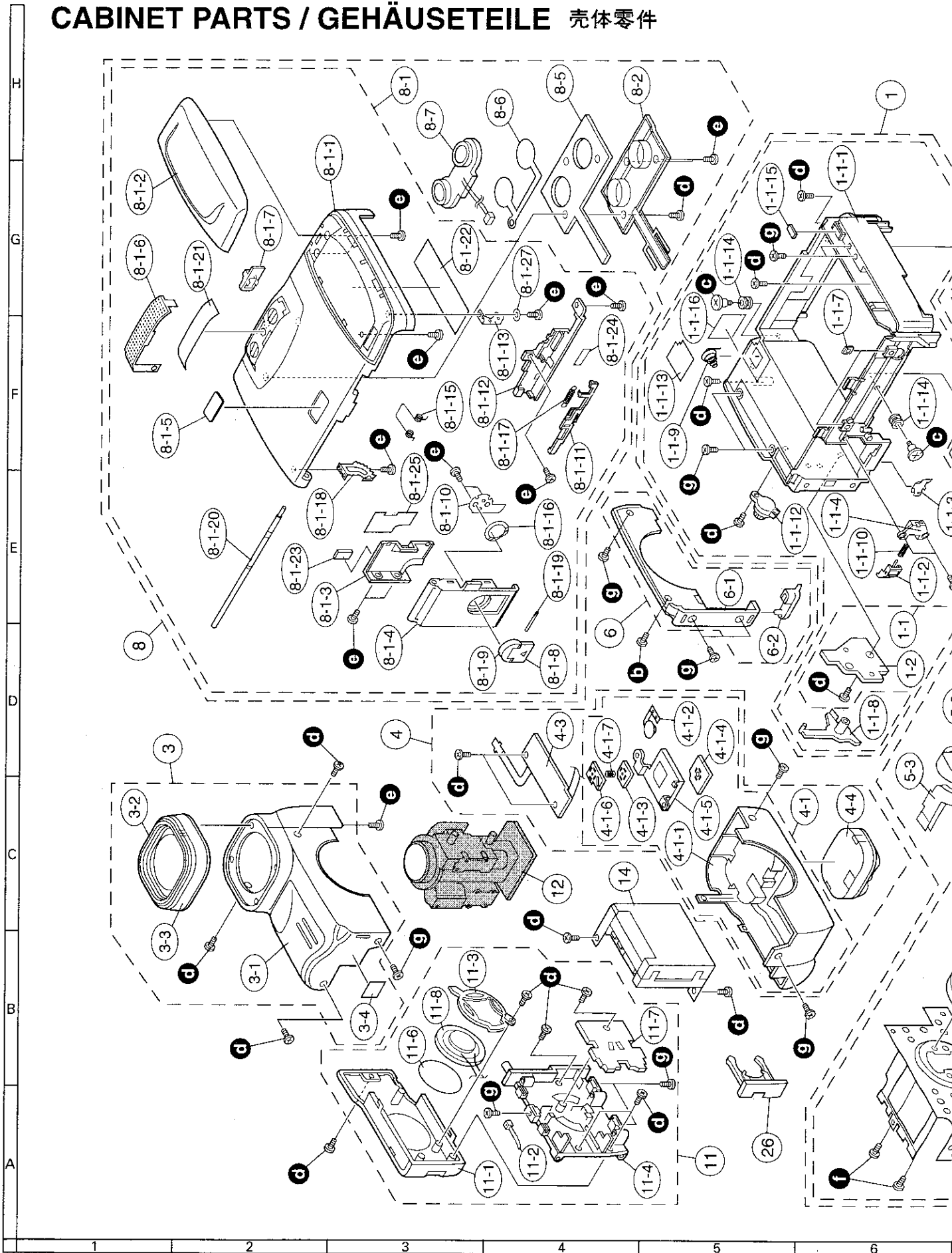

Ref. No.	Part No.	★	Description	Code	Ref. No.	Part No.	★	Description	Code
MECHANISM CHASSIS PARTS									
300	LCHSM0156GEZZ	J	Main Chassis Ass'y	AV	365	MSPRC0197GEFJ	J	Tu Guide Spring	AB
301	MLEVF0437GEZZ	J	Loading Lever Ass'y	AG	366	MSPRD0159GEFJ	J	Tu Guide Return Spring	AC
302	MARMM0113GEZZ	J	S Loading Arm Ass'y	AF	367	MSPRD0160GEFJ	J	AHC Pressure Spring	AC
303	MARMM0115GEZZ	J	Tu Loading Arm Ass'y	AF	368	MSPRT0394GEFJ	J	AHC Release Spring	AD
304	LBNDK3020GEZZ	J	Tention Band Ass'y	AG	369	MSPRC0198GEFJ	J	SI Roller Spring	AB
305	MLEVF0484GEZZ	J	Tention Arm Ass'y	AP	370	MSPRT0412GEFJ	J	Tu Lock Spring	AD
306	MLEVF0440GEZZ	J	Tention Control Lever Ass'y	AG	371	MSPRP0177GEFJ	J	Fast Gear Spring, x2	AD
307	MLEVF0442GEZZ	J	Pinch Drive Lever Ass'y	AH	380	LX-WZ1071GE02	J	CW 0.7-1.8 t 0.1, x4	AC
308	MLEVF0443GEZZ	J	Tu Guide Arm Ass'y	AG	381	LX-WZ1052GE00	J	CW 0.7-1.8 t 0.2, x3	AA
309	MLEVF0444GEZZ	J	S Gear Lever Ass'y	AH	382	LX-WZ1053GE00	J	CW 0.7-2.5 t 0.2, x6	AA
310	MLEVF0445GEZZ	J	Tu Gear Lever Ass'y	AG	383	LX-WZ1029GE00	J	CW 1.2-3.0 t 0.25, x2	AA
311	MARMM0117GEFW	J	Gear Lever Drive Arm	AE	384	LX-WZ1089GE00	J	CW 1.6-3.0 t 0.25, x2	AC
312	MLEVF0446GEZZ	J	VSR Brake Lever Ass'y	AF	385	LX-WZ1090GE00	J	CW 2.0-3.5 t 0.25, x2	AC
313	NGERH1247GEZZ	J	Swing Arm Ass'y	AL	386	XWHJZ10-02025	J	Washer 1.0-2.5 t 0.25	AB
314	MLEVF0447GEZZ	J	Brake Drive Lever	AF	387	LX-HZ3076GEFF	J	Screw M1.4xL3.0, x29	AA
315	MLEVF0449GEZZ	J	Eject Lever	AE	388	LX-JZ3002GEZZ	J	Screw M1.4xL3.0, x3	AA
316	MLEVF0450GEZZ	J	AHC Mounting Angle Ass'y	AG	389	LX-JZ3003GEFN	J	Screw M1.4xL6.0, x2	AC
317	LANGA0067GEFW	J	Reel Cover	AD	390	LX-BZ3131GEFN	J	Screw M1.4xL1.6, x4	AA
318	LANGG9098GEFW	J	Down Guide	AF	391	LX-BZ3181GEFN	J	Sp. Screw M1.2xL1.8, x2	AD
319	LANGJ0030GEFW	J	Mech. Fixing Angle-F	AE	392	LX-BZ3168GEFF	J	Sp. Screw M1.4xL2.0, x1	AD
320	LANGJ0031GEZZ	J	Mech. Fixing Angle-R	AE	393	LX-BZ3170GEFF	J	Sp. Screw M1.4xL6.25, x1	AD
321	LANGF9593GEFW	J	Loading Lever Cover Ass'y	AE	394	LX-BZ3167GEFN	J	Screw M1.4xL3.0, x1	AC
322	NGERH3044GEZZ	J	Main Cam	AF	396	LANGK0325TAFW	J	Mech. Fitting Angle	AE
323	MLEVF0482GEZZ	J	Tu Lock Lever	AF	397	PSPAG0077TA00	J	Floating Rubber	AC
324	MLEVF0483GEZZ	J	Tu Lock Release Lever	AD	398	LX-BZ0192TAFW	J	Floating Screw, x1	AB
326	LANGF9597GEFW	J	Dew Sensor Fitting Angle	AD	400	QPWBH5206GEZZ	J	Mode Switch-FPC	AG
327	MLEVP0259GEZZ	J	S Main Brake Ass'y	AC	410	LPOLM0054GEZZ	J	S Pole Base Ass'y	AL
328	MLEVP0260GEZZ	J	Tu Main Brake Ass'y	AE	411	LPOLM0055GEZZ	J	Tu Pole Base Ass'y	AL
329	PGiDM0134GEZZ	J	Guide Rail Ass'y	AK	412	NROLM0038GEZZ	J	Guide Roller Ass'y, x2	AW
330	MLEVP0261GEZZ	J	AHC Lever Ass'y	AG	413	NROLP0118GEZZ	J	SI Roller Ass'y	AP
331	NGERH1248GEZZ	J	Center Gear Ass'y	AE	414	PGiDP0028GEFW	J	Tu Roller	AE
332	NGERH1249GEZZ	J	Play Gear, x2	AE	415	NDAiV1068GEZZ	J	S Reel Base Ass'y	AU
333	NGERH1250GEZZ	J	Fast Gear, x2	AE	416	NDAiV1069GEZZ	J	Tu Reel Base Ass'y	AU
334	NGERH1251GEZZ	J	VSR Gear	AD	417	MLEVF0453GEZZ	J	Pinch Arm Ass'y	AT
335	MLEVP0262GEZZ	J	VSR Lock Lever	AD	418	NBLTT0011GEZZ	J	Timing Belt	AF
336	NGERH1255GEZZ	J	Pinch Cam	AD	419	PDMP-0011GEZZ	J	Damper	AG
337	NGERH1252GEZZ	J	Cam Relaying Gear	AD	420	RDTCH0036GEZZ	J	Dew Sensor	AL
338	NSFTP0033GEZZ	J	Eccentric Pin	AD	430	RMOTM1068GEZZ	J	Loading Motor Ass'y	AS
339	<i>Not Used</i>				431	RMOTV1017GEZZ	J	Capstan Motor	BE
340	LDAiS1008GEZZ	J	L Lever Catcher	AD	432	RPLU-0087GEZZ	J	Brake Solenoid	AL
341	PGiDM0151GEZZ	J	Lock Cam	AC	433	QSW-R0037GEZZ	J	Mode Switch	AG
342	LHLDF1094GEZZ	J	PWB Holder-S	AD	450	CPWBN5346GE01	J	Sensor PWB Unit Ass'y	AZ
343	LHLDF1095GEZZ	J	PWB Holder-Tu Ass'y	AF	451	<i>Not Available</i>	-	Sensor PWB Unit	—
344	MLEVP0263GEZZ	J	Blake Latch Lever	AD	452	QSW-M0039GEZZ	J	Recognition Switch	AF
345	PCOVP1022GEZZ	J	Drum Cover	AD	453	QTANZ0001GEZZ	J	Mic Contact	AE
346	LANGA0072GEFW	J	Tu Reel Stopper	AC	454	RH-PX0180TAZZ	J	Cassette LED	AE
350	PGiDS0046GEFW	J	Tu Guide Upper Flange	AE	455	LHLDP1154GEZZ	J	LED Holder-S	AD
351	PGiDS0047GEFW	J	Tu Guide Bottom Flange	AE	456	LHLDP1155GEZZ	J	LED Holder-Tu	AD
360	MSPRT0389GEFJ	J	Brake Latch Lever Spring	AD	457	RH-PX0181TAZZ	J	S/E Sensor	AF
361	MSPRT0390GEFJ	J	Main Brake Spring	AC	458	RDTCM0002TAZZ	J	Reel Sensor	AE
362	MSPRT0391GEFJ	J	Gear Lever Spring	AC	459	QSW-M0040GEZZ	J	Down Switch	AE
363	MSPRP0168GEFJ	J	VSR Gear Spring	AE	460	PCOVP3012GEFW	J	Down Switch Cover	AD
364	MSPRT0392GEFJ	J	T Arm Spring	AD	461	MSPRP0180GEFW	J	Cassette Control Spring	AD
					462	PSLDM9091TAZZ	J	Shield Sheet	AD
					500	<i>Not Available</i>	-	Drum Ass'y, with Drum Base	—
					501	DDRMW0021HE02	J	Upper/Lower Drum Ass'y	BZ

Ref. No.	Part No.	★	Description	Code
MECHANISM CHASSIS PARTS (Continued)				
502	PGiDM0135GEZZ	J	Drum Base Ass'y	AL
503	MSPRP0169GEFJ	J	PBT-Spring	AD
504	LX-BZ3169GEZZ	J	Screw M1.4xL2.5, x3	AA
701	Not Available	-	Head Amp. Unit	—

Ref. No.	Part No.	★	Description	Code
CASSETTE CONTROL PARTS				
600	CHLDX3076GE01	J	Cassette Control Ass'y	AX
601	Not Available	-	Housing Ass'y	—
602	MSPRT0396GEFJ	J	Up Spring	AE
603	MSPRT0406GEFJ	J	Lock Spring	AD
604	MSPRT0397GEFJ	J	Cassette Control Auxiliary Spring	AE
605	MLEVF0452GEFW	J	Lock Lever	AE
606	LX-WZ1030GE00	J	CW 1.6-4.0 t 0.25, x1	AA

**CASSETTE CONTROL EXPLOD VIEW /
EXPLOSIONSDARSTELLUNG DER KASSETTENSTEUERUNG**
盒室控制器的分解图

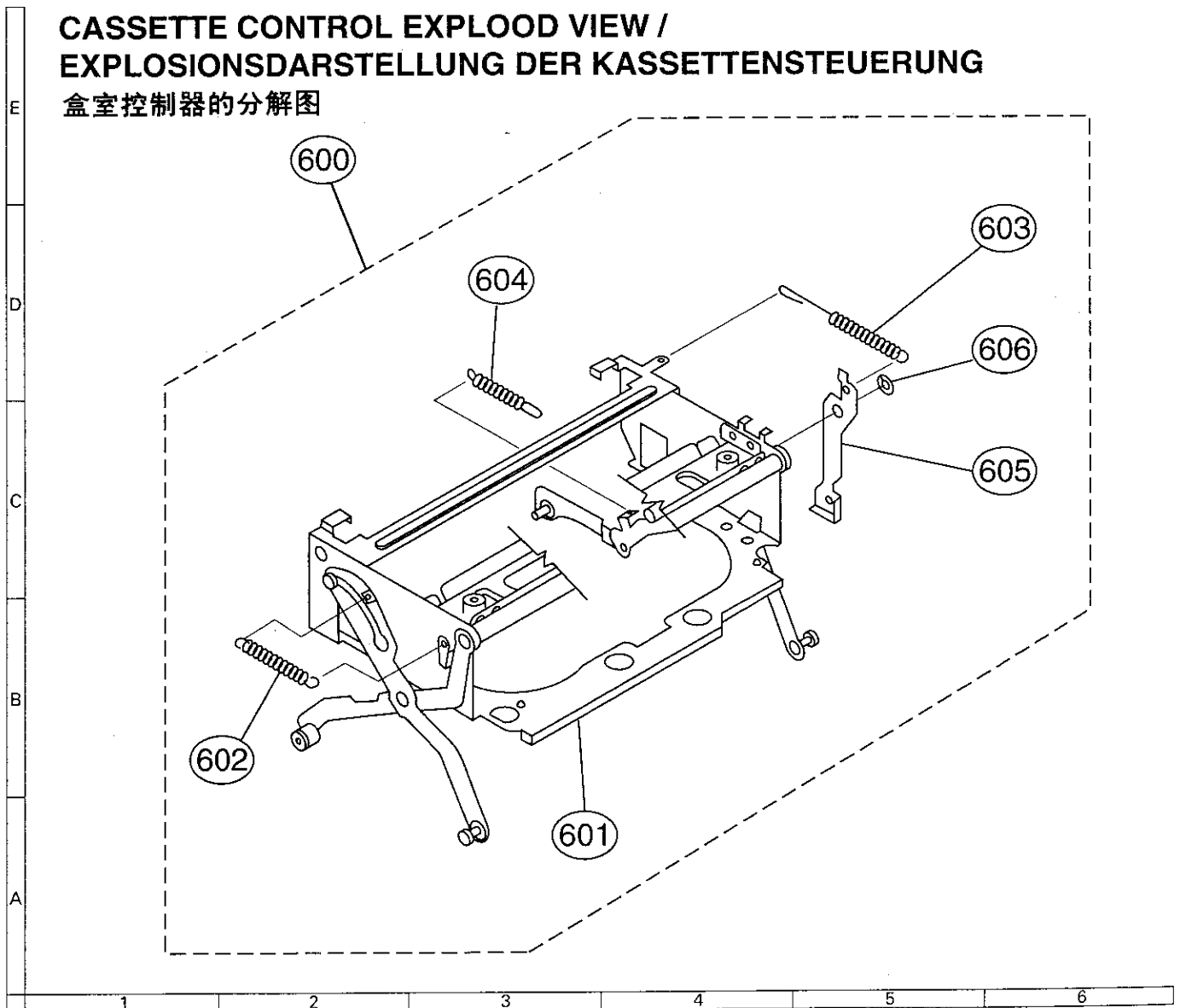

Ref. No.	Part No.	★	Description	Code
----------	----------	---	-------------	------

SUPPLIED ACCESSORIES MODEL VL-DC1E

ACCESSORIES

UBATI0016TAZZ	J	Battery Pack	BR
GDAI-1048TAZZ	J	Tripod Adaptor	AT
RTPEV0015TAZZ	J	Mini DV Video Cassette	BB
QCNW-1170TAZZ	J	S-Video Cable	AP
QCNW-1335TAZZ	J	Audio/Video Cable	AM
QCNW-1378TAZZ	J	DC Output Cable	AT
QPLGA0010GEZZ	J	AC Plug Adaptor	AF
QJAKZ0041TAZZ	J	A/V Pack	AX
RRMCG0045TASA	J	Infrared R/C Unit	AY
UADP-0216TAZZ	J	AC Adaptor/Battery Charger (For Australia and New Zealand)	BT
UADP-0219TAZZ	J	AC Adaptor/Battery Charger (For Hong Kong)	BT
UADP-0233TAZZ	J	AC Adaptor/Battery Charger (For Asia and Middle East)	BT
UADP-0235TAZZ	J	AC Adaptor/Battery Charger (For Russia)	BT
UBATL0004TAZZ	J	Lithium Battery x2	AF
UBNDS0012TAZZ	J	Shoulder Strap	AV
UBNDT0088TAZZ	J	Hand Strap	AM
TINSL0052TAZZ	J	Operation Manual	AX

ACCESSORIES (NOT REPLACEMENT ITEM)

TCTLZ0008TAZZ	-	Option Guide	—
---------------	---	--------------	---

SUPPLIED ACCESSORIES MODEL VL-DC1H

ACCESSORIES

UBATI0016TAZZ	J	Battery Pack	BR
GDAI-1048TAZZ	J	Tripod Adaptor	AT
RTPEV0015TAZZ	J	Mini DV Video Cassette	BB
GCOVH1172TAZZ	J	Sun Food	AV
QCNW-1170TAZZ	J	S-Video Cable	AP
QCNW-1335TAZZ	J	Audio/Video Cable	AM
QCNW-1378TAZZ	J	DC Output Cable	AT
QJAKZ0041TAZZ	J	A/V Pack	AX
RRMCG0048TASA	J	Infrared R/C Unit	AV
UADP-0215TAZZ	J	AC Adaptor/Battery Charger	BU
UBATL0004TAZZ	J	Lithium Battery x2	AF
UBNDS0012TAZZ	J	Shoulder Strap	AV
UBNDT0088TAZZ	J	Hand Strap	AM
TINSE0154TAZZ	J	Service Guide	AA
TINSE0208TAZZ	J	Operation Manual	AQ
TINSE0209TAZZ	J	Quick Guide	AE

ACCESSORIES (NOT REPLACEMENT ITEM)

TCTLZ0008TAZZ	-	Option Guide	—
TCADN0071TAZZ	-	Regist Card	—
TGANL0004TAZZ	-	Guarantee Card	—

Ref. No.	Part No.	★	Description	Code
----------	----------	---	-------------	------

SUPPLIED ACCESSORIES MODEL VL-DC1S

ACCESSORIES

UBATI0016TAZZ	J	Battery Pack	BR
GDAI-1048TAZZ	J	Tripod Adaptor	AT
RTPEV0015TAZZ	J	Mini DV Video Cassette	BB
GCOVH1172TAZZ	J	Sun Food	AV
QCNW-1170TAZZ	J	S-Video Cable	AP
QCNW-1335TAZZ	J	Audio/Video Cable	AM
QCNW-1378TAZZ	J	DC Output Cable	AT
QJAKZ0041TAZZ	J	A/V Pack	AX
RRMCG0048TASA	J	Infrared R/C Unit	AV
UADP-0214TAZZ	J	AC Adaptor/Battery Charger	BT
UBATL0004TAZZ	J	Lithium Battery x2	AF
UBNDS0012TAZZ	J	Shoulder Strap	AV
UBNDT0088TAZZ	J	Hand Strap	AM
TINSL0051TAZZ	J	Operation Manual-1	AX
TINSL0058TAZZ	J	Operation Manual-2	AX

ACCESSORIES (NOT REPLACEMENT ITEM)

TCTLZ0008TAZZ	-	Option Guide	—
TCADN0071TAZZ	-	Regist Card	—
TGANL0004TAZZ	-	Guarantee Card	—

PACKING PARTS (NOT REPLACEMENT ITEM)

SPAKC6612TAZZ	-	Packing Case (VL-DC1E)	—
SPAKC6611TAZZ	-	Packing Case (VL-DC1H)	—
SPAKC6610TAZZ	-	Packing Case (VL-DC1S)	—
SPAKP6068TAZZ	-	Polystyrene Cover (Set)	—
SPAKA6164TAZZ	-	Buffer Material (Set)	—
SPAKA6167TAZZ	-	Buffer Material (Accessories)	—
SPAKF0197TAZZ	-	Buffer Material (Spacer)	—

23. PACKING OF THE SET/ LIEFERUMFANG 包装方法

• Switch setting positions/Schalter-Einstellpositionen 各旋钮设定位置

Name/Bezeichnung 名称	Setting position/Einstellposition 设定位置
Power switch/Hauptschalter 电源开关	OFF/AUS (OFF) OFF(关)位置

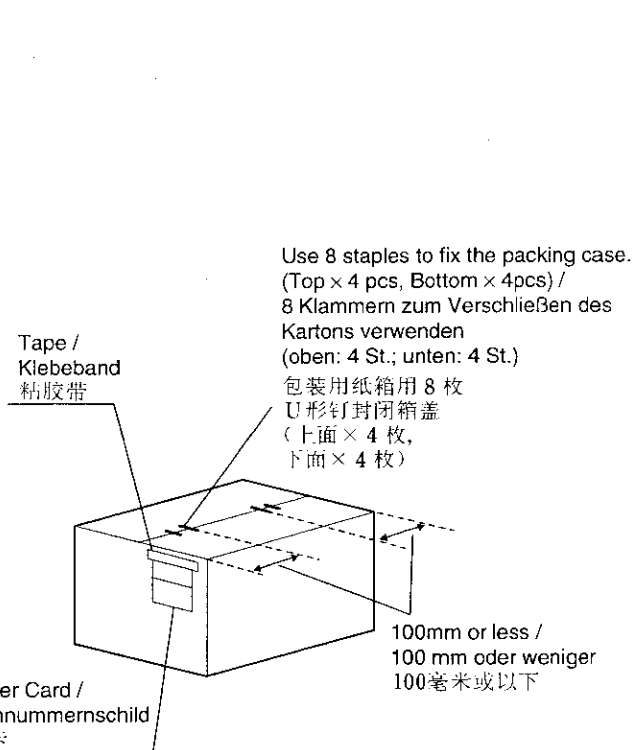
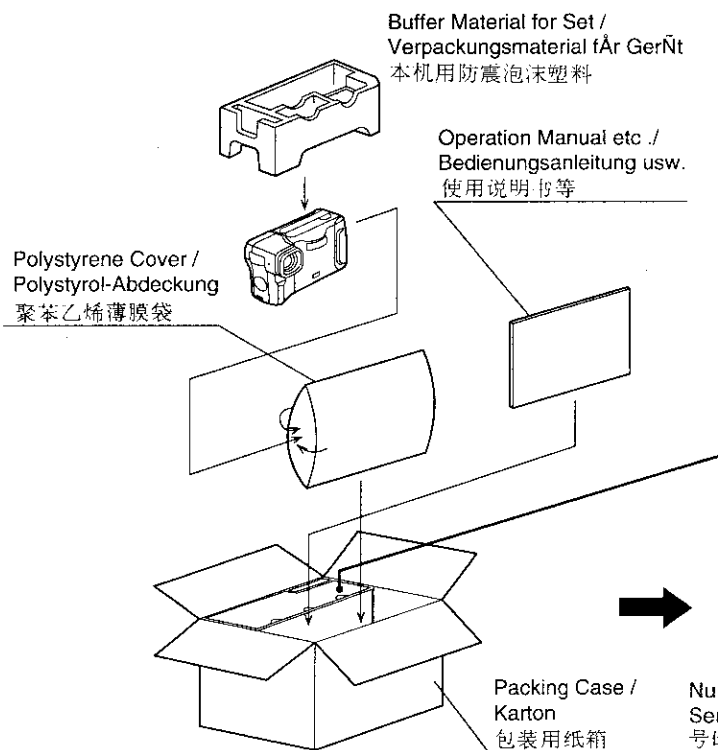
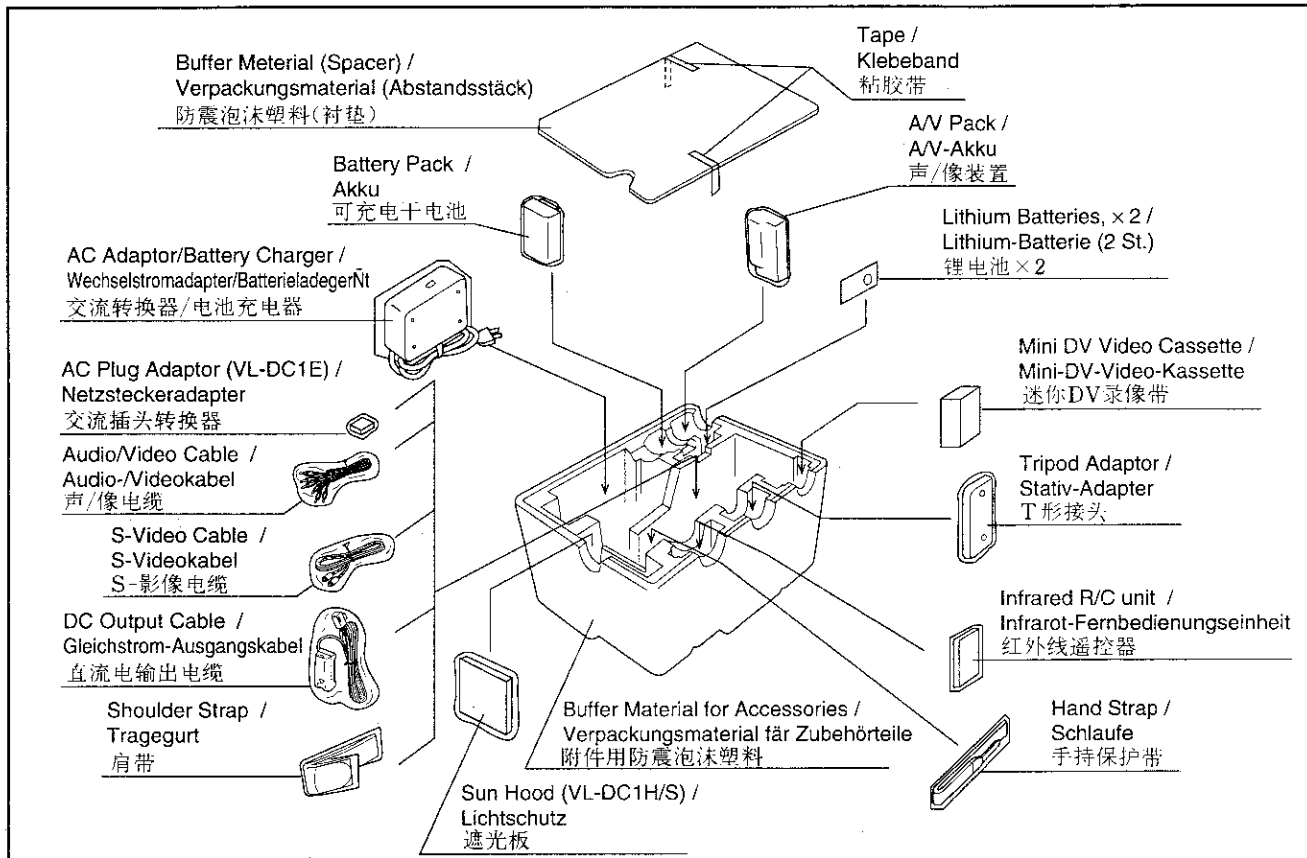

SHARP

SHARP®

MODEL
VL-DC1H

OPERATION MANUAL

Please read this operation manual carefully
before using the VIEWCAM.

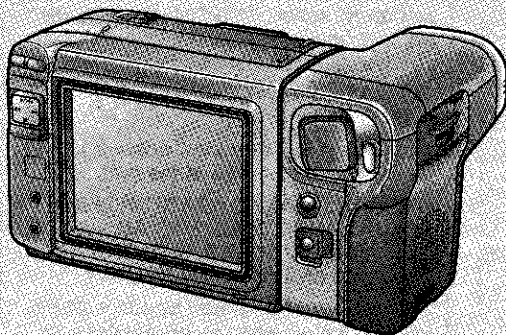

Mini **DV**

•The **Mini DV** logo is a trademark.

SHARP
VIEW•CAM

This equipment complies with the requirements of Directives 89/336/EEC and 73/23/EEC as amended by 93/68/EEC.

Dieses Gerät entspricht den Anforderungen der EG-Richtlinien 89/336/EWG und 73/23/EWG mit Änderung 93/68/EWG.

Ce matériel répond aux exigences contenues dans les directives 89/336/CEE et 73/23/CEE modifiées par la directive 93/68/CEE.

Dit apparaat voldoet aan de eisen van de richtlijnen 89/336/EEG en 73/23/EEG, gewijzigd door 93/68/EEG.

Dette udstyr overholder kravene i direktiv nr. 89/336/EEC og 73/23/EEC med tillæg nr. 93/68/EEC.

Quest' apparecchio è conforme ai requisiti delle direttive 89/336/EEC e 73/23/EEC, come emendata dalla direttiva 93/68/EEC.

H εγκατάσταση αυτή ανταποκρίνεται στις απαιτήσεις των οδηγιών της Ευρωπαϊκής Ένωσης 89/336/ΕΟΚ και 73/23/ΕΟΚ, όπως οι κανονισμοί αυτοί συμπληρώθηκαν από την οδηγία 93/68/ΕΟΚ.

Este equipamento obedece às exigências das directivas 89/336/CEE e 73/23/CEE, na sua versão corrigida pela directiva 93/68/CEE.

Este aparato satisface las exigencias de las Directivas 89/336/CEE y 73/23/CEE, modificadas por medio de la 93/68/CEE.

Denna utrustning uppfyller kraven enligt riktlinjerna 89/336/EEC och 73/23/EEC så som kompletteras av 93/68/EEC.

Dette produktet oppfyller betingelsene i direktivene 89/336/EEC og 73/23/EEC i endringen 93/68/EEC.

Tämä laite täyttää direktiivien 89/336/EEC ja 73/23/EEC vaatimukset, joita on muutettu direktiivillä 93/68/EEC.

WARNING

TO PREVENT SHOCK HAZARD, DO NOT EXPOSE THIS APPLIANCE TO RAIN OR MOISTURE.

This equipment should be used with approved DC 3.6 V \equiv only or recommended AC adaptor.

CAUTION

To prevent electric shocks and fire hazards, do NOT use any other power source.

Important:

Recording and playback of any material may require consent. Please refer particularly to the provisions of the Copyright Act 1956, the Dramatic and Musical Performers Protection Act 1958, the Performers Protection Acts 1963 and 1972 and to any subsequent statutory enactments and orders.

CAUTION

To prevent shock, do not open the cabinet. No user serviceable parts inside. Refer servicing to qualified dealer or service centre.

Power supply:



The rating label of the AC adaptor is located on the bottom of the unit.

WARNING: THIS AC ADAPTOR IS NOT FOR USE WITH TOYS. THIS AC ADAPTOR IS FOR USE WITH SHARP VIEWCAM MODEL VL-DC1H ONLY.

This unit can be operated by connecting it to either the AC adaptor, battery pack, or optional car battery adaptor/battery charger.

The AC adaptor incorporates the AUTO VOLTAGE (AC 110–240 V, 50/60 Hz) function.

SPECIAL NOTE FOR USERS IN THE U.K.

The mains lead of this product is fitted with a non-rewireable (moulded) plug incorporating a 3A fuse. Should the fuse need to be replaced, a BSI or ASTA approved BS 1362 fuse marked  or  and of the same rating as above, which is also indicated on the pin face of the plug, must be used.

Always refit the fuse cover after replacing the fuse. Never use the plug without the fuse cover fitted.

In the unlikely event of the socket outlet in your home not being compatible with the plug supplied, cut-off the mains plug and fit an appropriate type.

DANGER: The fuse from the cut-off plug should be removed and the cut-off plug destroyed immediately and disposed of in a safe manner.

Under no circumstances should the cut-off plug be inserted elsewhere into a 13A socket outlet, as a serious electric shock may occur.

To fit an appropriate plug to the mains lead, follow the instructions below:

IMPORTANT: The wires in the mains lead are coloured in accordance with the following code:

Blue: Neutral

Brown: Live

As the colours of the wires in the mains lead of this product may not correspond with the coloured markings identifying the terminals in your plug, proceed as follows:

- The wire which is coloured blue must be connected to the plug terminal which is marked N or coloured black.
- The wire which is coloured brown must be connected to the plug terminal which is marked L or coloured red.

Ensure that neither the brown nor the blue wire is connected to the earth terminal in your three pin plug.

Before replacing the plug cover make sure that:

- If the new fitted plug contains a fuse, its value is the same as that removed from the cut-off plug.
- The cord grip is clamped over the sheath of the mains lead and not simply over the lead wires.

IF YOU HAVE ANY DOUBT, CONSULT A QUALIFIED ELECTRICIAN.

Your VIEWCAM is designed to record in SP mode only. It will not perform normal playback for programmes prerecorded in LP mode.

NOTE:

The VIEWCAM's LCD panel is a very high technology product with more than 112,000 thin-film transistors*, giving you fine picture detail. Occasionally, a pixel may appear on the screen as a fixed point of blue, green, red, or black. Please note that this does not affect your VIEWCAM's performance.

* Specifications are subject to change without notice.

Contents

Important Information

Supplied Accessories	3
Optional Accessories	4
Precautions	5
About the DV (Digital VCR)	8
Mini DV Cassette	9
Part Names	11

Preparation

Installing the Memory Backup Battery	13
Installing the Battery in the Remote Control	13
Using the AC Adaptor/Battery Charger	14
Inserting and Removing the Battery Pack	15
Powering the VIEWCAM from an AC Outlet	16
Powering the VIEWCAM from Your Car Battery ...	17
Inserting and Removing a Mini DV Cassette	18
Using the Hand Strap	19
Using the Tripod Adaptor	19
Attaching the Shoulder Strap	19
Using the Sun Hood	20
Controlling the Monitor Display	21
Using the On-screen Menu	22
Warning Indicators	24
Setting the Area, Date and Time	25
Setting the VIEWCAM to Full Auto Mode	26
Remaining Recording Time Display	27
Remaining Battery Power Display	27

Basic Operations Camera Recording

Easy Camera Recording with Full Auto	28
Zooming	29
Setting the Digital Zoom	29
Digital Quick Zoom (Extend Zoom)	30
Auto Focus	30
Backlight Compensation (BLC)	31
Gain-up (Cat's Eye)	31
Digital Image Stabilization (DIS)	32
Macro Shots	32
Fade In and Fade Out	33
Tips on Recording Positions	34
Hints for Better Shooting	34

**Basic Operations
Playback**

Playback 35
 Volume Control 35
 Fast Forward and Rewind 35
 Displaying the Date and Time of Recording 36
 Video Search 36
 Still 36
 Slow 36
 Frame Advance 37
 Strobe Playback 37
 Turning Off the LCD Monitor Backlight 37
 Programme Search 38
 Using the Time Code 39
 Using the Tape Counter 40
 Skip Playback 41
 Using the Infrared Remote Control 43

**Useful Features for
Camera Recording**

Self Recording 44
 Manual Focus 47
 Setting the Shutter Speed 48
 White Balance Lock 49
 Manual Iris 50
 Strobe Recording 50
 Recording a Five-second Still Image
 (Snapshot) 51
 Still Recording 51
 Lighting 52
 World Clock 53
 Picture/Backlight Adjustments 56
 Recording with the Wide Screen (16:9) 57
 Quick Return 58
 Edit Search 58

**Connections and
Editing**

Using the A/V Pack 59
 Connections for Playback on a TV with
 Audio/Video Jacks 59
 Connection to TV without Audio/Video Jacks 60
 Connection to TV via VCR 61
 Watching Played-back Tapes on a TV 61
 Editing 62

Others

Florescent Lamp Backlight 63
 Before Requesting Service 64
 Specifications 66

Supplied Accessories

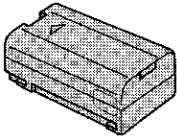

Battery pack
BT-L2

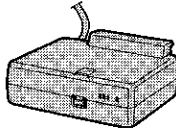

AC adaptor/battery
charger

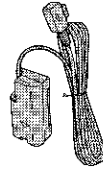

DC output cable
(2.0 m)

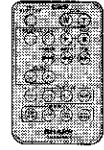

Infrared remote
control



Audio/video cable
(RCA type) (1.5 m)

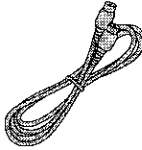

S-video cable
(1.5 m)



AV pack

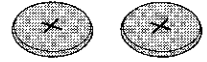

Lithium battery × 2



Shoulder strap

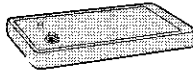

Tripod adaptor

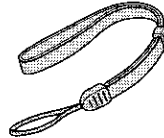

Hand strap





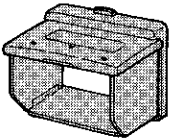

Mini DV video cassette

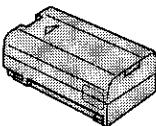
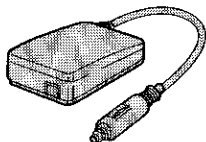
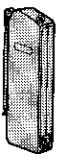
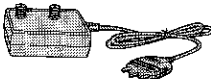
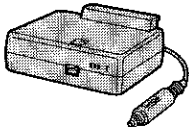
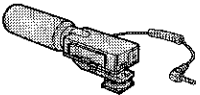
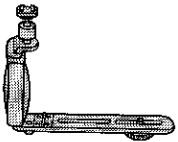

Sun hood

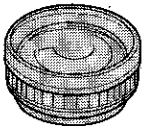
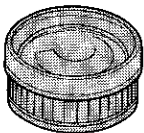
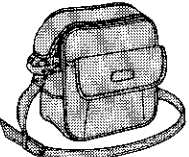
Optional Accessories

 <p>Battery pack BT-L2</p>	 <p>Car battery adaptor VR-410CA</p>	 <p>TV Tuner pack VR-HT30P</p>	 <p>RF converter VR-H30RF</p>
 <p>Car battery adaptor/ battery charger VR-410CH</p>	 <p>Stereo microphone VR-1MC</p>	 <p>Accessory shoe adaptor VR-30AD</p>	 <p>Tripod adaptor for 180° recording VR-33FA</p>
 <p>Telephoto conversion lens VR-TC37</p>	 <p>Wide conversion lens VR-WC37</p>	 <p>Soft case VR-33SC</p>	 <p>Mini DV video cassette VR-DVM60N</p>

Precautions

Use & Care

- **After operation, remove the battery pack from the unit.**

- **Do not aim the lens at the sun.**

Do not allow direct sunlight to strike the VIEWCAM lens or LCD panel, whether recording is in progress or not, as it may damage the CCD sensor or LCD panel surface. Be particularly careful when recording outside.

- When shooting in dark places, avoid sudden brightly lit objects or light sources, such as the sun. Otherwise, the image may white out. Should this happen, point the camera in a different direction until the picture returns to normal.

- **Avoid magnetic sources.**

Using the VIEWCAM near strong fluorescent lights, motors, televisions, or other magnetic sources may adversely affect recorded images.

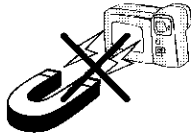

- **Remember to remove the cassette tape, turn off the power, and remove the battery pack when the VIEWCAM is not in use.**

- **Using the VIEWCAM near a broadcasting station or other powerful transmission source may cause buzzing or picture deterioration.**

- **Avoid shocks and dropping.**

Do not drop or otherwise subject the VIEWCAM to hard shocks or strong vibrations. Bumping or striking the unit during recording will generate noise in the recorded image.

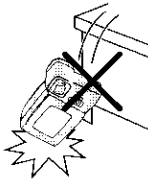

- **Avoid placing the VIEWCAM in close proximity to lighting equipment.**

The heat from incandescent lights may deform the VIEWCAM, or cause it to malfunction.

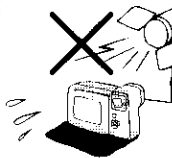

- **Always respect prohibitions or restrictions on the use of electronic equipment on commercial flights or in other sensitive areas.**

- **Watch the temperature and humidity.**

You can use your VIEWCAM at 0°C to +40°C and at 30% to 80% relative humidity. Do not store the unit in an unventilated car in the summer, in direct sunlight, or near strong heat sources; this can result in severe damage to the unit's casing and circuitry. Be careful when handling the unit after it has been left in a hot place, such as the ones described above.

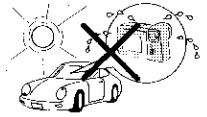

- **Avoid situations where water, sand, dust or other foreign matter could get on or inside the VIEWCAM. Such substances could cause malfunctions.**

Do not use your VIEWCAM in areas with excessive smoke or steam.

Do not leave your VIEWCAM in areas with excessive dust or moisture.

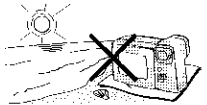

Such environments can cause mildew to form on this unit's lenses. Be sure to provide ample ventilation.

- **Some small, portable tripods may be difficult to attach and may not be sturdy enough to support your VIEWCAM. Be sure to use only a strong, stable tripod.**



- **When using your VIEWCAM in a cold environment, the colour LCD view screen may appear less bright. This often occurs in cold environments immediately after the power is turned on. This is not a malfunction. If this occurs, put the VIEWCAM in a warmer location for some time before use. To prevent excessive cooling, wrap the VIEWCAM in a thick cloth (a blanket, etc.).**

Dew Formation

• What is "dew formation"?

When cold water is poured into a glass, dew drops form on the glass. This clinging of water drops is called dew formation.

• When dew forms in your VIEWCAM.

Dew will gradually form on the head drum of your VIEWCAM and make the video tape stick to the head. This causes damage both to the head and the tape. When dew formation occurs, recording and playback may not function properly.

Dew is likely to form in the following circumstances:

- when moving the VIEWCAM from a cold place to a warm place,
- when placing the VIEWCAM in a cold room which is then heated rapidly,
- when moving the VIEWCAM outdoors from an air conditioned room,
- when placing the VIEWCAM in the direct path of air blowing from an air conditioner,
- when placing the VIEWCAM in a humid room.

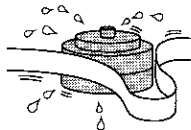

• How to prevent trouble due to dew formation.

When using the VIEWCAM in a place where dew formation is likely to occur, allow the VIEWCAM and the video tape to acclimate to the surroundings for about one hour. For example, when bringing the VIEWCAM indoors after skiing, place it in a plastic bag and allow it to adapt to room conditions for some period of time.

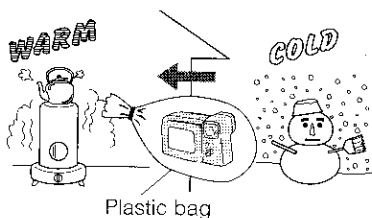

- ① Be sure to tightly seal the plastic bag containing the VIEWCAM.
- ② Remove the bag when the air temperature inside it reaches the temperature of the surroundings.

• "Dew" warning feature

If dew forms, the word "DEW" flashes on the LCD monitor, and the power will automatically turn off in approximately 10 seconds.

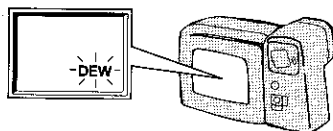

- ① If the word "DEW" flashes on the LCD monitor, remove the cassette, leave the cassette compartment open, and wait several hours to allow the VIEWCAM to acclimate to the surrounding temperature.
- ② To use the VIEWCAM again, turn on the power after waiting for several hours. Be sure that the word "DEW" has disappeared from the monitor screen.
- ③ Do not insert a cassette while the word "DEW" is flashing; this may result in damage to the tape.
- ④ Since dew forms gradually, it may take 10 to 15 minutes before the dew warning feature engages.

• How to continually maintain good recording.

If used in a variety of places, eventually your VIEWCAM may not function properly due to accumulation of dirt on the head drum. Please pay special attention to the following points when using your VIEWCAM.

- 1) Dew formation on the head drum.
- 2) Worn video tapes:
Using a damaged or soiled video tape may also soil the head drum, causing the picture to be blurred or nothing to be recorded on the video tape. Do not use such a video tape.
- 3) VIEWCAM use in a humid or dusty place.
Use in extremely humid or dusty places may cause damage to your VIEWCAM.

• When the video heads become clogged.

Using the VIEWCAM when the video tape is dirty may cause the head to clog, producing noise on the recorded image or preventing the image from being recorded at all. Under such circumstances, contact the nearest SHARP service centre or your dealer for further advice.

(Video head cleaning can be done by using a commercially available cleaning tape. However, excessive use of the cleaning tape may also cause damage to the video heads. Please read the instructions accompanying the cleaning tape carefully, before using it.)

Precautions

Battery Pack

This VIEWCAM uses a lithium-ion type battery pack. It is not necessary to store the lithium-ion battery pack in a fully discharged state. Also, if stored in the charged state, the battery will gradually self-discharge, resulting in decreased recording time. Charge the battery pack soon (a day) before use.

Battery pack consumption

- Recording with many starts and stops, frequent zooming, and recording in low temperatures will somewhat shorten actual recording times. Accordingly, be sure to turn off the power when not recording. Use of an auxiliary battery pack is recommended to prevent undesirable interruptions in your recording.
- Do not use an insufficiently charged or weak battery pack. Such battery packs may cause the power to automatically stop during VIEWCAM operation to protect both the battery pack and the unit.

Battery power is consumed even when the VIEWCAM's power is turned off. If you are not going to use your VIEWCAM immediately, remove the battery pack. (See page 15.)

Note:

- Use only the SHARP BT-L2 battery pack. It is designed specifically for use with this VIEWCAM.

How to use the marker on the battery pack

The marker is provided to indicate the battery's charge condition. Slide the switch to indicate the charge condition as shown below.

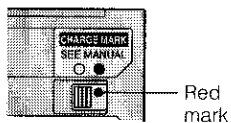

Position	Charge condition
	Before charging
	After charging

Temperature during charging

- Store the battery pack in a dry, cool place.
- Charge the battery pack at temperature of 10°C to 30°C.

For long battery lifetime

- Charge the battery pack (lithium-ion type) at least once every six months.
- Do not leave the battery pack being charged for long periods of time.

Cautions:

- If the battery pack is misused, there is danger of fire or explosion. Pay close attention to the following:
 1. Do not dispose of in fire.
 2. Do not allow metallic objects to come in contact with the terminals. This can cause a short circuit.
 3. Do not disassemble or repair by yourself.
 4. Do not use any battery charger other than those designed for use with these battery packs.
 5. Do not place the battery pack under direct sunlight or in excessively hot places (over 60°C) such as the dashboard of cars.
 6. Do not expose to moisture, water, or salt water.
 7. Do not drop or subject to strong force.
 8. Keep battery out of reach of children and in the original package until ready to use.
 9. Dispose of used batteries promptly.
- The battery pack will become warm during charging and use. This is normal and not a malfunction.
- The battery pack has a limited service life. If the period of use becomes noticeably shorter with a normal charge, the battery pack is at the end of its service life. Replace it with a new battery pack.
- For safety, keep the battery pack in its protective cover when it is not being used. If the metal parts of the battery pack come in contact with other metal objects, there is a danger that a short circuit may occur.

About the DV (Digital VCR)

The "DV" trademark can only be used on digital VCR products which have been evaluated and have met the specifications set by the **HD Digital VCR Conference for Standardization of Consumer Use Digital VCR Formats**.

1. High horizontal resolution

Detailed, accurate images with the highest level of horizontal resolution for home use.

2. Clear colour reproduction with virtually no colour contamination

Provides three times the colour resolution of conventional VCRs (based on Sharp models). Clear images with virtually no distracting colour contamination (which usually appears as red).

3. Standard use of TBC (time base collector) to prevent jittery images

Ensures stable images with a high signal-to-noise ratio.

4. PCM digital recording

PCM digital recording gives you high-quality stereo sound that puts you in the middle of the action.

- An 8 mm, VHS, or Beta VCR (or camcorder) can be connected using the A/V pack, and the A/V cable or S-video cable.

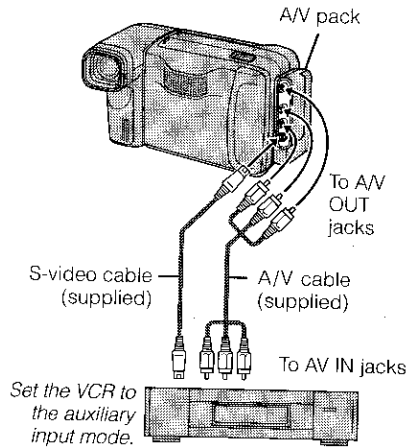

• Audio and video cannot be input to this VIEWCAM.

- You can also watch tapes by connecting to a conventional TV.

DV digital VCR tapes

There are two kinds of DV digital VCR tapes: the Mini DV cassette and the larger DV cassette used for extended playback and recording. This VIEWCAM only operates with Mini DV cassettes. DV cassettes cannot be used. Be sure to use Mini DV cassettes with the **Mini DV** mark.

Mini DV cassette



DV cassette

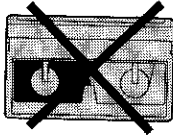

DV digital technology and conventional VCRs

- 8 mm, VHS, or Beta cassettes cannot be used for playback or recording with this unit.

8 mm cassette



VHS cassette



Beta cassette

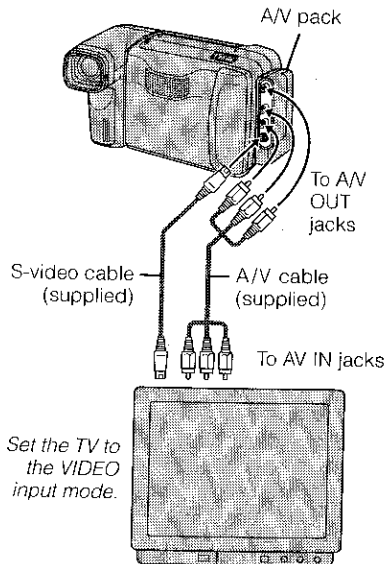

Note:

- This VIEWCAM reproduces the highest picture quality when used with an ME tape. We recommend you use an ME tape for high-quality recording and playback.

Precautions

Mini DV Cassette

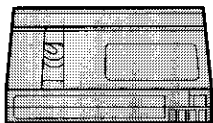

Precautions when using a Mini DV cassette

- Be sure to use only Mini DV cassettes with the **“DV”** mark.
- This **VIEWCAM** can record and play back with Mini DV cassettes with cassette memory, but it cannot record or play back this memory.
- **8 mm, VHS, or Beta cassettes cannot be used for playback or recording with this unit.**

8 mm cassette VHS cassette Beta cassette



- Do not insert anything into the holes on the bottom of the Mini DV cassette or block them in any way.
- Avoid placing the cassette in an area conducive to dust or mold.
- Do not place the cassette near magnetic sources such as electric clocks or magnetic devices as this may adversely affect recorded material.
- When a previously recorded Mini DV cassette is used again for recording, the previously recorded material will be automatically erased.
- The Mini DV cassette will not operate if inserted on the wrong side.
- Do not repeatedly insert and eject the Mini DV cassette without running the tape as this may cause uneven tape winding and damage the tape.
- Do not place the cassette in direct sunlight, near strong heat sources, or in areas with excessive steam.
- Store the cassette in its case and stand it in an upright position.
- If the tape is not properly wound, rewind the tape.
- Do not drop the cassette or subject it to excessive shocks.

To protect recordings against accidental erasure

Slide the protect tab on the rear of the Mini DV cassette to the “SAVE” position.

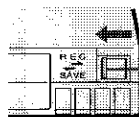

Erasure protect tab

To record over a previously recorded tape

Slide the protect tab to the “REC” position.

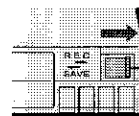

Erasure protect tab

Copyright protection

- The digital VCR has far superior recording and playback ability than the traditional analog VCR, and in order to protect digital video software copyrights, a system for managing copyrights has been established. Some digital video software may have pre-recorded copyright protection signals and cannot be played back on this VIEWCAM. When playing back a copyright-protected tape, the “COPYRIGHT PROTECTED.” warning will be displayed on the monitor screen. Copyright protection signals cannot be recorded with this VIEWCAM.

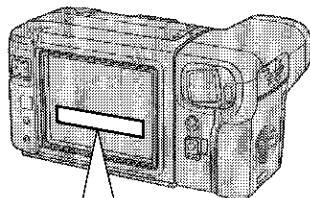

COPYRIGHT PROTECTED.

Care

Cleaning and maintenance

- Many plastic parts are used in the VIEWCAM casing. Do not use thinners, benzenes or other strong chemical cleaners. These may cause discoloration and damage to the casing.
- Clean the casing with a soft, dry cloth. If the casing is particularly dirty, wipe the casing with a tightly wrung cloth dampened with a diluted, neutral detergent. Then wipe it again with a soft, dry cloth.
- Use a soft cloth to wipe finger marks and other soiling off the LCD monitor and lens protector.
- If the lens needs cleaning, first remove the lens protector by turning it anticlockwise. Then clean the lens with a soft cloth, or compressed air and lens papers designed for photographic lenses.

Using Your VIEWCAM Abroad

Television system signals and electrical system voltages and frequencies vary substantially from country to country. When you are abroad, please check the sections below before using the AC adaptor or connecting the VIEWCAM to a TV.

AC Power Sources

The AC adaptor is compatible with 50 Hz and 60 Hz electrical systems in the range of 110 V to 240 V AC.

Car Cigarette Lighter Power Adaptor (Optional Accessory)

This can be used with 12 V and 24 V negative-ground cars only. Do not use it with positive-ground electrical systems.

Television Signal Systems

In any country, you can always watch the video picture by using the LCD monitor screen. However, if you want to watch the picture on a TV screen, the TV must be PAL system compatible. PAL is used in the following countries:

Germany, Great Britain, Sweden, Denmark, Austria, Belgium, Switzerland, Italy, Spain, Holland, Finland, Portugal, Norway, Hong Kong, Thailand, Australia, New Zealand, Singapore, Kuwait, China, etc.

Part Names

For details on the use of each control, refer to the page number indicated in the brackets.

Front view

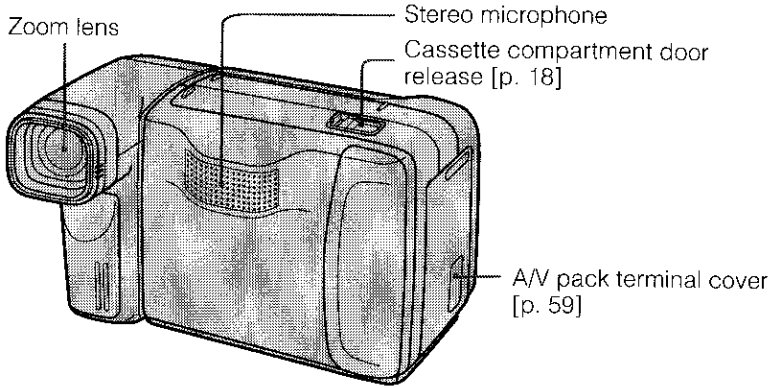

When the cassette compartment door is opened

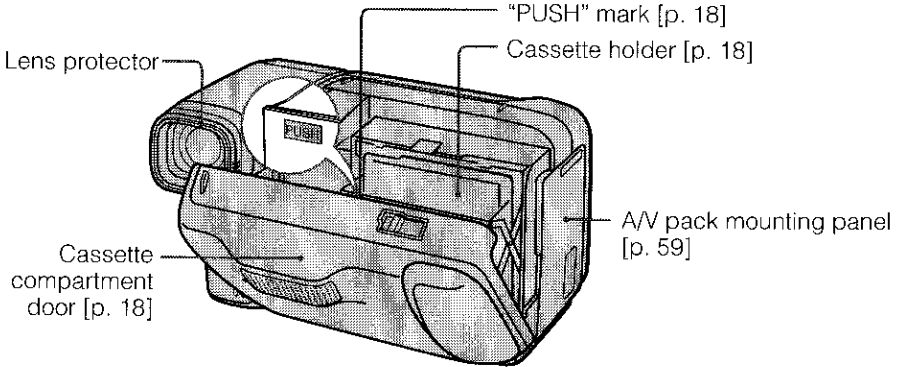

Removing the Lens Protector

Before mounting the optional wide or telephoto conversion lens, remove the lens protector by turning it anticlockwise.

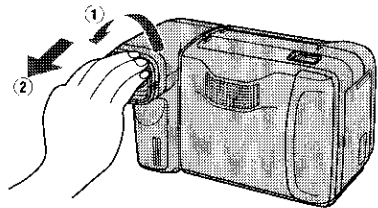

Rear view

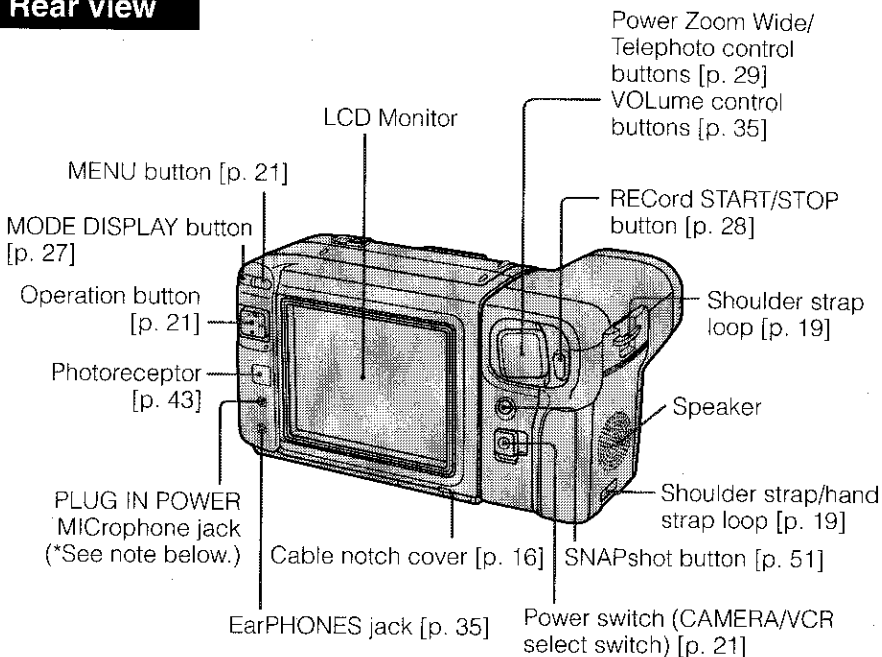

*About the PLUG IN POWER MIC Jack

This external microphone jack outputs a DC voltage of 4.0 V. It is for use with the microphone supplied with the sports case optional accessory for this VIEWCAM, or with any 2.5–4.0 volt DC use condenser-type microphone with a 3.5 mm diameter plug. The use of other types of microphones may result in damage to the microphone or the VIEWCAM.

Side view

When camera module is rotated

Fluorescent lamp compartment [p. 63]

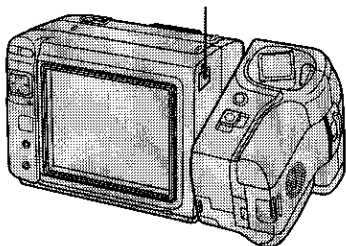

Bottom view

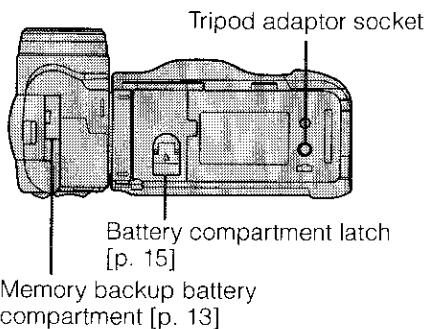

Preparation

Installing the Memory Backup Battery

- 1 Pull out the battery holder from the memory backup battery compartment on the bottom of the VIEWCAM, using a pointed object such as the point of a pen.

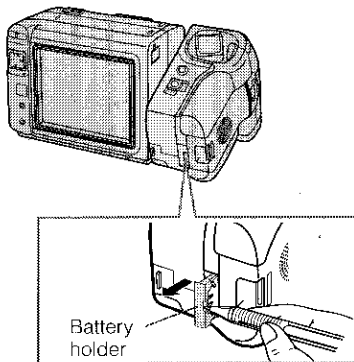

- 2 Insert the supplied lithium battery into the holder with the + side facing outward.



- 3 Insert the battery holder back into its compartment and push it in completely.

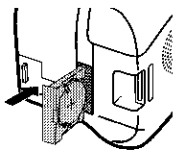

CAUTION: Danger of explosion if battery is incorrectly replaced. Replace only with the same or equivalent type CR2025 recommended by the equipment manufacturer.

WARNING: KEEP THIS BATTERY AWAY FROM CHILDREN. IF SWALLOWED, CONSULT A PHYSICIAN IMMEDIATELY FOR EMERGENCY TREATMENT.

CAUTION: BATTERY MAY EXPLODE IF MISUSED OR INSTALLED WITH POLARITY REVERSED. DO NOT RECHARGE, DISASSEMBLE OR DISPOSE OF IN FIRE.

Cautions:

- If the lithium battery is installed with polarity reversed, the backup function will fail.
- Do not short-circuit, recharge, disassemble, or heat the battery.
- Should the battery leak, wipe the battery compartment clean, and then insert a new battery.

Notes:

- The lithium battery is used to back up the calendar and other memory functions.
- The battery will last about one year of normal usage.
- Replace the battery with a new CR2025 cell when the VIEWCAM's time indicator starts to fall behind the correct time.

Installing the Battery in the Remote Control

- 1 Hold the remote control facing down, then pull out the battery holder while pressing the tab toward the centre.

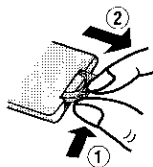

- 2 Install the supplied CR2025 lithium battery with its + side matching the ⊕ marked side of the battery holder.
- 3 Insert the holder in the direction of the arrow. Make sure that the ⊕ side faces the back of the remote control.

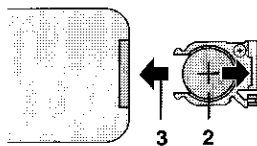

Using the AC Adaptor/Battery Charger

Precautions:

- If used near a radio, the AC adaptor/battery charger may interfere with reception.
- Prevent flammables, liquids, and metal objects from entering the unit.
- This is a sealed unit. Do not attempt to open or modify it.
- Do not damage, drop, or subject the unit to vibration.
- Do not leave the unit in direct sunlight.
- Avoid using the unit in humid or extremely hot places.
- If the power source becomes disconnected during recording, playback, or other operations, the tape will remain wrapped around the drum and may be damaged. Reconnect the power source to the main unit immediately.
- The supplied AC adaptor/battery charger is specially designed for use with the VIEWCAM, and should not be used as a power supply for other camcorders.

Charging the Battery Pack

- 1 Be sure the DC output cable is disconnected from the AC adaptor/battery charger, then insert the AC plug into a power outlet. The POWER indicator will light up.

To power outlet  POWER indicator

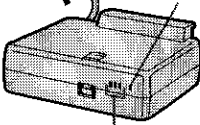

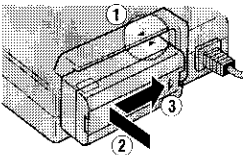

CHARGE indicators

- 2 Align the ▼ mark on the battery with the ▲ mark on the charger (1), then guide the battery into the groove. Pressing the battery (2), slide it in the direction of the arrow (3) until it locks into place.



- 3 When the battery is charged, all three CHARGE indicators will light up. Remove the battery and the AC plug.

CHARGE indicators

	Charging starts. (Indicator starts flashing.)
	Now charging.
	Charging completed. (The indicators will turn off approximately 90 to 120 minutes after charging is completed.)

Charging time when using AC adaptor/battery charger and maximum time for continuous camera recording and playback

Battery pack	Charging time	Max. recording time	Max. playback time
BT-L2	Approx. 90 min.	Approx. 50 min.	Approx. 50 min.

Notes:

- The above playback time is based on operation of the VIEWCAM without use of the A/V pack and with the volume set at the middle setting.
- The battery and charger warm up during charging. This is not a malfunction.
- Charging time depends on the ambient temperature and the condition of the battery.

Cautions:

- Charge only SHARP model BT-L2 battery pack. Other types of batteries may burst, causing personal injury and damage.
- Do not incinerate or mutilate the battery pack. It may present the risk of a rise in surface temperature, and/or the release of flammable vapors.
- Replace battery with BT-L2 only. Use of another battery may present a risk of fire or explosion.

Inserting and Removing the Battery Pack

Inserting the Battery Pack

- 1 Raise the battery compartment latch on the bottom of the VIEWCAM (:1:), turn it anticlockwise (:2:) and open the compartment door (:3:).

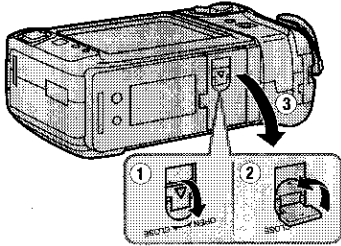

- 2 Insert the battery pack into the compartment, as shown, and push it in completely.

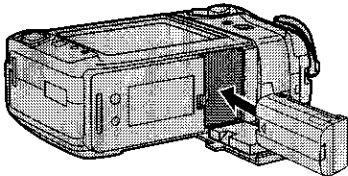

- 3 Close the door (:1:), turn the latch clockwise to secure it firmly (:2:), and then push down the latch (:3:).

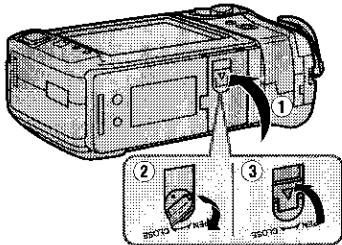

Removing the Battery Pack

Perform step 1 above, then, with the VIEWCAM facing down, press the battery release (:1:) and remove the battery (:2:).

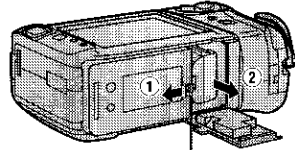

Battery release

Cautions:

- BEFORE REMOVING THE BATTERY PACK, ALWAYS STOP THE TAPE AND TURN THE POWER OFF. If you remove the battery pack during recording or playback, the tape will remain wound around the video head drum and may be damaged. Should the power source (battery or adaptor) become disconnected during operation, reconnect it again immediately.
- Do not expose the battery compartment door to strong force, as it may come off.
- Be sure to close the battery compartment door firmly, especially during operations. If you do not, the battery pack may come off or VIEWCAM operation may fail because of the poor contact pressure.
- Remove the battery pack from the VIEWCAM or disconnect the VIEWCAM from the AC adaptor if the VIEWCAM will not be used for a long time.
- When removing the battery pack, do not tilt the VIEWCAM so that the battery compartment faces down. The battery pack may fall out.

Battery Pack Handling

- Make sure that you take enough battery packs with you to provide two to three times your estimated recording time. See page 14.
- Recording time will be reduced in cold weather.
- The battery will drain in Recording Standby mode. Turn off the power if you will not be recording again soon.

Powering the VIEWCAM from an AC Outlet

- 1 Slide the cable notch cover in the direction of the arrow.

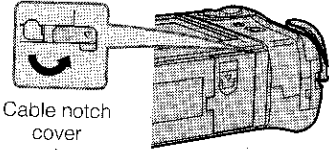

- 2 Raise the battery compartment latch on the bottom of the VIEWCAM (1), turn it anticlockwise (2) and open the compartment door (3).

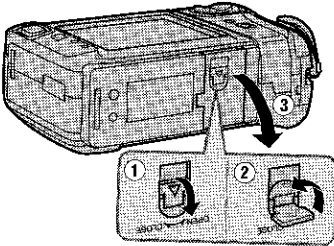

- 3 Insert the DC cable connecting plate into the compartment and push it in until it clicks (1). Pass the cable through the cable notch (2), and close the door (3). Turn the latch clockwise to lock the door, and push down the latch (4).

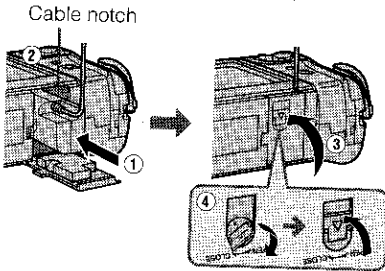

- 4 Insert the DC cable plug into the DC OUT jack on the AC adaptor (1), then plug the power cord into a power outlet (2). The POWER indicator on the AC adaptor will light up.

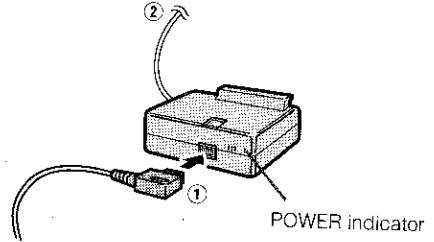

Removing the DC Cable from the VIEWCAM

- 1 Perform steps 1 and 2 above.
- 2 Remove the cable from the notch (1), press the release as shown (2), and remove the connecting plate from the compartment (3).

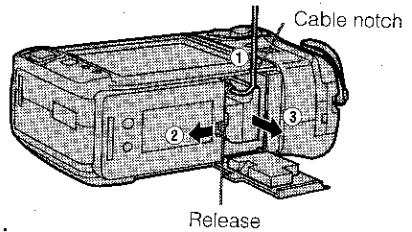

Cautions:

- Turn the Power switch off before removing the DC cable.
- When removing the DC cable, grasp the connecting plate, not the cable itself, and pull it out of the compartment.
- When removing the connecting plate, do not tilt the VIEWCAM so that the battery compartment faces down. The connecting plate may fall out.

Note:

- After removing the DC cable, return the cable notch cover to the former position.

Powering the VIEWCAM from Your Car Battery

Preparation

Use the optional VR-410CH car battery adaptor/battery charger (or the VR-410CA car battery adaptor) when you want to power the VIEWCAM from the battery of your car while it is idling or being driven.

- Slide the cable notch cover in the direction of the arrow.

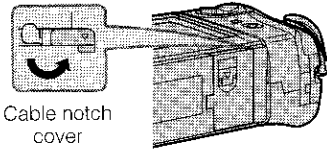

- Raise the battery compartment latch on the bottom of the VIEWCAM (1), turn it anticlockwise (2) and open the compartment door (3).

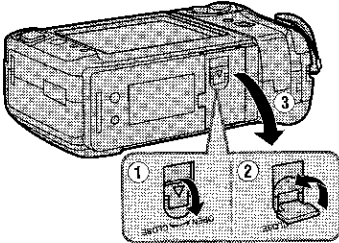

- Insert the DC cable connecting plate into the compartment and push it in until it clicks (1). Pass the cable through the cable notch (2), and close the door (3). Turn the latch clockwise to lock the door, and push down the latch (4).

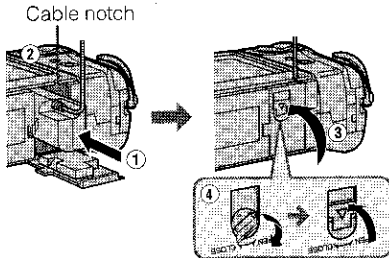

- Insert the DC cable plug into the DC OUT jack on the VR-410CH (or VR-410CA).

- Start the car engine and leave it idling, then insert the power cord plug of the car battery adaptor into the cigarette lighter socket. (The POWER indicator on the VR-410CH will light up.)

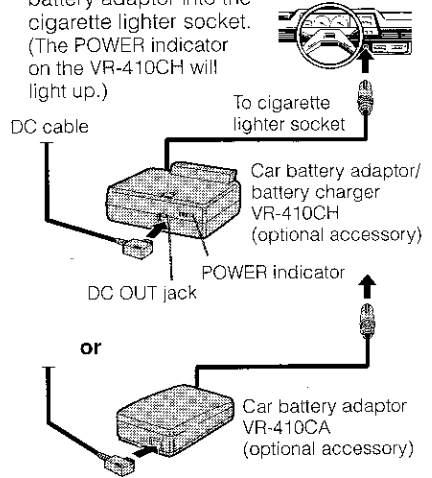

Notes:

- See the VR-410CH (or VR-410CA) operation manual for details.
- You can recharge the battery pack by using the VR-410CH in basically the same manner as the supplied AC adaptor/battery charger (see page 14).
- The VR-410CA cannot be used to recharge battery packs.

Cautions:

- Use in only DC 12 V or 24 V negative ground system cars. Positive-ground car batteries CANNOT BE USED. Check your car operation manual or consult a local car dealer.
- Use the VR-410CH (or VR-410CA) only when the car is idling or being driven. Otherwise, the car's battery will be drained.
- Charge only SHARP model BT-L2 battery pack. Other types of batteries may burst, causing personal injury and damage.
- Before starting the car engine, the VR-410CH (or VR-410CA) must be unplugged from the cigarette lighter socket.
- Before removing either the DC plug or the cigarette lighter plug, the VIEWCAM's Power switch should be set to OFF.
- Do not apply strong force to the DC cable connected to the VIEWCAM as this will cause a malfunction.
- The battery used in this device may present the risk of a rise in surface temperature and/or the release of flammable vapors. Do not incinerate or mutilate. Replace battery with BT-L2 only. Use of another battery may present a risk of fire or explosion.

Replacing the Cigarette Lighter Plug Fuse

The fuse may blow if the car battery adaptor/battery charger is improperly connected. If this happens, replace the fuse.

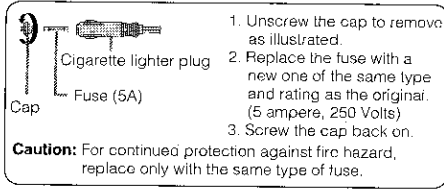

Note:

- If the car battery adaptor/battery charger still does not operate properly after the fuse is replaced, take it to a Sharp-authorized service centre.

Inserting and Removing a Mini DV Cassette

Inserting a Cassette

- 1 While holding down the Lock button, set the Power switch to CAMERA or VCR.

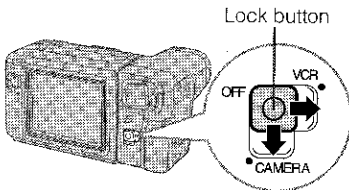

- 2 Slide the release and open the cassette compartment door.
 - The cassette holder automatically opens after about 10 seconds.

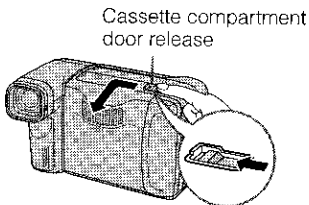

- 3 Insert the tape cassette fully with the window facing outwards, and with the erasure protect tab facing upwards.

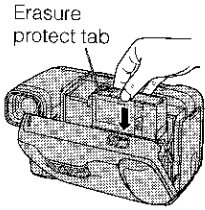

- 4 Press the "PUSH" mark gently until the cassette holder clicks into place.

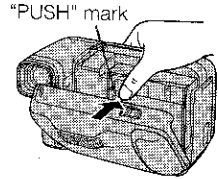

- 5 Close the compartment door pressing its centre until it clicks into place.

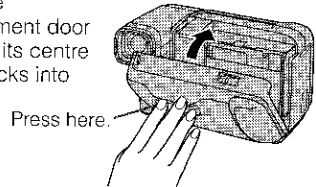

Removing a Cassette

Perform steps 1 and 2 above, then take out the cassette.

Cautions:

- Be careful not to get your fingers caught in the cassette compartment.
- Do not apply force to the cassette compartment except for pressing the "PUSH" mark to close it.
- Do not tilt the VIEWCAM or hold it upside down when you are inserting or removing a cassette. It may damage the tape.
- Remove the cassette if you will not use the VIEWCAM for a long time.
- If you do not press the cassette holder closed correctly in step 4 above, the VIEWCAM's cassette protection mechanism might eject the cassette. If this happens, repeat the insertion procedure.
- Do not attempt to pick up the VIEWCAM by the cassette compartment door.
- If the compartment door does not close when gently pressed into position, check the compartment door release. The door release may not be completely opened as shown below on the left. In this case, slide the door release in the direction of the arrow and press the compartment door closed.



- If the battery power is too low, you may not be able to eject the cassette or operate the Power switch. Replace the battery pack with a fully charged one.

Using the Hand Strap

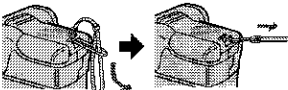
- 1 Thread the narrow end of the hand strap through the VIEWCAM's hand strap eyelet. Then pass the wide end of the strap through the narrow loop at the other end. 
- 2 Pull the wide end and tighten the strap. 

Fixing the Hand Strap on Your Wrist

Pass your right hand through the loop of the hand strap. Then move the slider toward your wrist until the strap fits your wrist snugly.

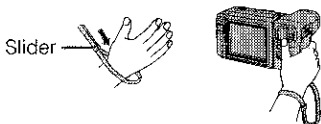

Caution:

- Be careful not to drop the VIEWCAM when attaching the hand strap, or during operation.

Using the Tripod Adaptor

When you use the VIEWCAM with a tripod, you must first attach the supplied tripod adaptor to the VIEWCAM.

Raise the adaptor's screw latch, and turn the latch clockwise to firmly fix the screw into the VIEWCAM's tripod adaptor socket.

- To connect your tripod to the tripod adaptor, firmly fix the mounting plate screw of your tripod into the adaptor's tripod socket. For details, see the user's manual for your tripod.

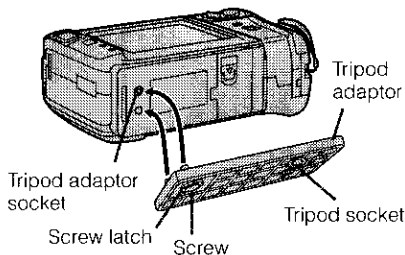

Caution:

- Do not connect your tripod to the VIEWCAM without using the tripod adaptor. The tripod may not balance properly and fall over, resulting in serious damage to the VIEWCAM.

Attaching the Shoulder Strap

- 1 Hold one end of the strap and thread it through the loop below the speaker on the lens section. **Note:**
 - If the hand strap is attached to the loop, remove it first.
- 2 Thread the end of the strap through the long slider and move the long slider in the direction of the arrow to secure.
- 3 Loosen the buckle, and then pass the strap through it.
- 4 Draw the strap in the direction of the arrow (1), and then secure the end of the strap with the short slider (2).
- 5-8 Use the same procedure to attach the other end of the strap to the loop above the speaker.

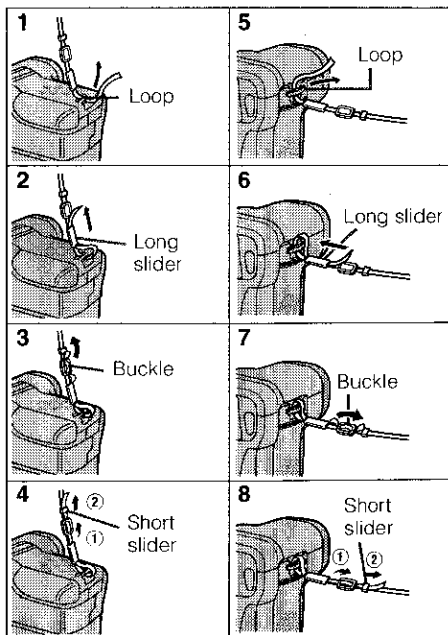

Handling the LCD Monitor

- Do not let anything press against the monitor screen, and do not expose it to shock, as it may break.
- Do not put the VIEWCAM on a table, or any other surface, with the monitor screen facing down.
- Use a soft cloth to clean the screen.

Using the Sun Hood

We recommend that you use the supplied sun hood when recording on a sunny day.

Attaching the Sun Hood

Align the two tabs on the sun hood with the VIEWCAM monitor, and press in the direction of the arrows until the sun hood clicks into place.

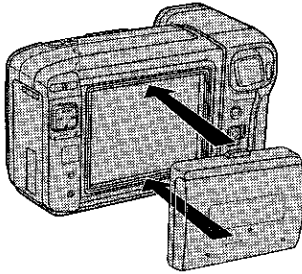

Opening the Sun Hood

Open the sun hood by lifting the top cover in the direction of the arrow. (The side and bottom covers will open automatically.)

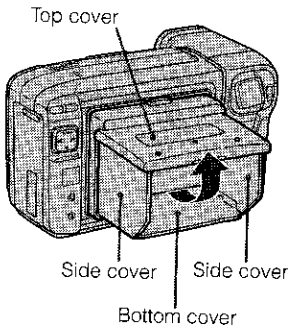

Closing the Sun Hood

Fold in the sun hood covers in the order shown below.

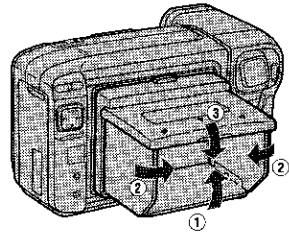

Gently press the top cover until it clicks into place.

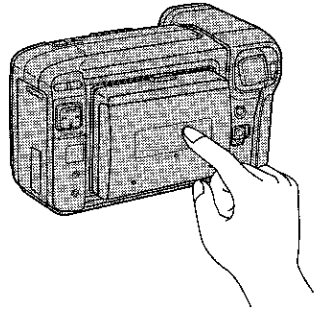

Note:

- Be sure to close the sun hood before transporting the VIEWCAM. (If the VIEWCAM is transported with the sun hood open, the sun hood may fall off or become damaged.)

Removing the Sun Hood

Press the top and bottom tabs of the sun hood as indicated by the arrows, then pull off the sun hood in the direction of the arrow.

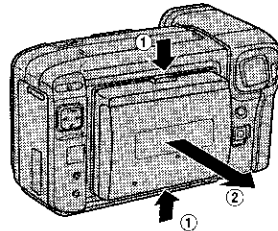

Caution:

- Do not leave the sun hood or VIEWCAM in an unventilated car in direct sunlight. The high temperature may cause a deformation of the casing.

Controlling the Monitor Display

You can use various functions and make mode settings while viewing the monitor display.

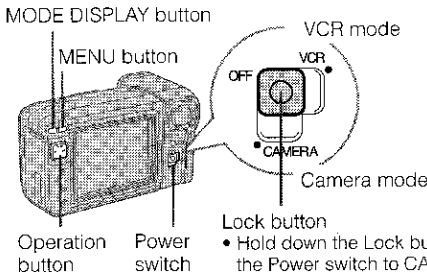

Notes:

- The monitor illustrations in this operation manual are for the purpose of explaining the functions of the VIEWCAM, and may differ from the actual monitor displays.
- The displays below are those when a cassette is loaded in the VIEWCAM and the power is supplied from a battery pack.

Camera mode (when the Power switch is set to CAMERA)

- Each time you press the MENU button, the screen changes from 14 to 44.
- With the 44 screen displayed, press \blacktriangleright on the Operation button (E3) to select "MENU". Each time you press \blacktriangleleft or \blacktriangleright on the E3 button, the screen changes from MENU-PAGE 11 to 41.
- If the area, date and time have not been set, MENU-PAGE 44 appears when you press \blacktriangleright on the E3 button to select "MENU" on the 44 screen (see page 25).

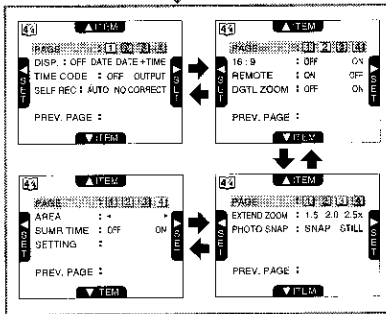
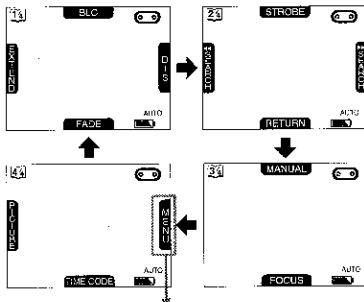

VCR mode (when the Power switch is set to VCR)

- Each time you press the MENU button, the screen changes from 13 to 33.
- With the 33 screen displayed, press \blacktriangleright on the E3 button to select "MENU". The menu screen will appear.

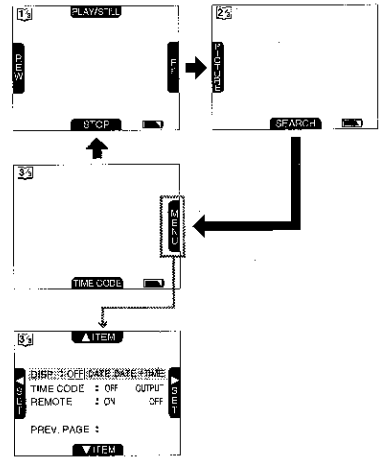

About the Operation button (E3)

Use this button to select and set the various functions on the monitor by pressing ① \blacktriangleright / \blacktriangleleft , ② \blacktriangleleft / \blacktriangleright , ③ \blacksquare , or ④ \blacktriangleright as shown.

- Press to move the cursor.

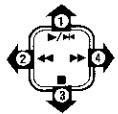

Note:

- The \blacktriangleright , \blacktriangleleft , \blacksquare , \blacktriangleleft , or \blacktriangleright buttons on the remote control cannot be used to move the cursor, or select or set any of the various functions on the monitor.

Using the On-screen Menu

- 1 To display the Camera mode menu screen:**
Hold down the Lock button and slide the Power switch to CAMERA. Then perform steps 2–4.

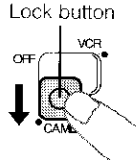

- To display the VCR mode menu screen:**
Hold down the Lock button and slide the Power switch to VCR. Then perform steps 2 and 3.

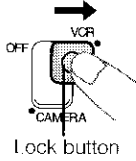

- 2** Press the MENU button until the [4] screen appears. (Select [3] in VCR mode.)
Ex. Camera mode

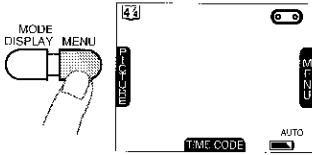

- 3** Press \blacktriangleright on the Operation button (E) to select "MENU". MENU-PAGE [1] will appear on the monitor.
- There is only one menu page in VCR mode. Skip step 4.

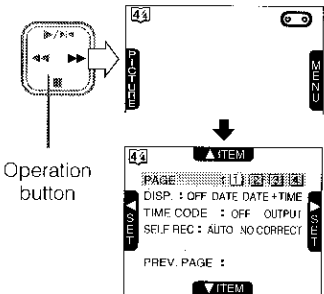

Note:

- If the area, date and time have not been set, MENU-PAGE [4] appears.

- 4** Press \blacktriangleleft or \blacktriangleright on the [E] button to change from MENU-PAGE [1] to [4].
Ex. Camera mode

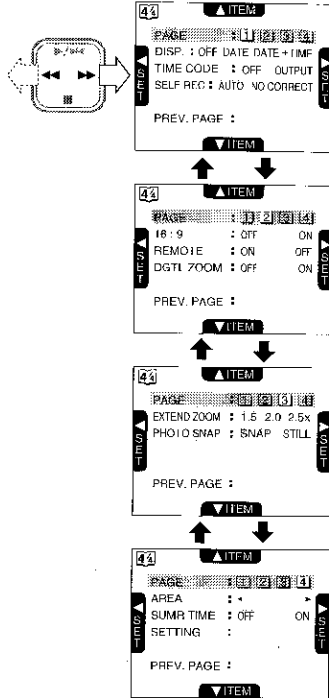

- 5** Press $\blacktriangleright/\blacktriangleleft$ or \blacksquare on the [E] button to select the menu item you wish to set.

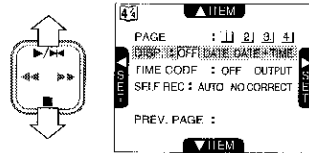

- 6** Press \blacktriangleleft or \blacktriangleright on the [E] button to set the desired mode.
- Each time you press the button, the item setting changes as shown on the following page.

Preparation

1) Camera mode

Preparation

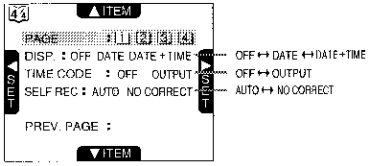

Press ◀ or ▶ on the button to change from MENU-PAGE [1] to [4].

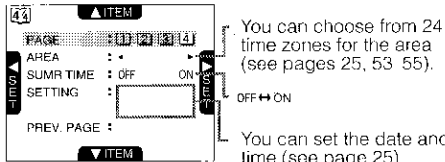
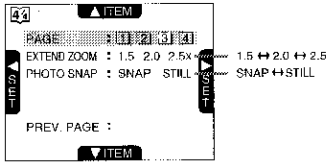
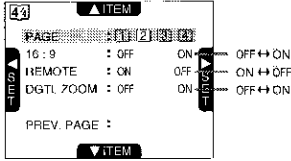

You can choose from 24 time zones for the area (see pages 25, 53-55).

You can set the date and time (see page 25).

2) VCR mode

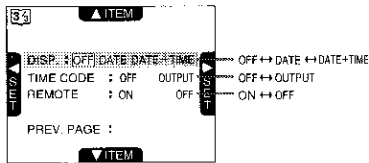

7 After completing the setting, press the MENU button. The menu screen will disappear.

Note:

- Certain menu items are common to both the Camera and VCR modes. If the "REMOTE" menu item, for example, is set to "OFF" in the Camera mode, it will automatically be set to "OFF" in the VCR mode.

Returning to the Previous Screen

Press on the button to select "PREV. PAGE" and then press ◀ or ▶ to select "SET" to return to the previous screen.

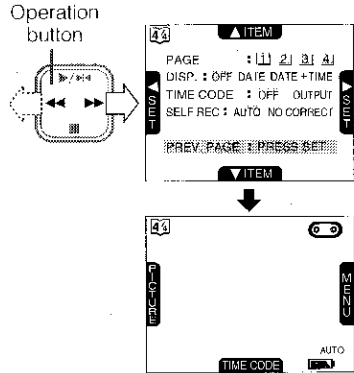

Warning Indicators

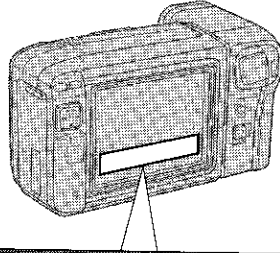

Display for the first 3 seconds	Display after the first 3 seconds	Description of warning
EJECT THE CASSETTE.	EJECT THE CASSETTE.	The video cassette is defective and should be removed.
DEW	DEW	Dew has formed inside the VIEWCAM. Wait for a few hours until the dew disappears (see page 6). About 10 seconds after this warning appears, the VIEWCAM turns off, and the display goes off too.
BATTERY IS TOO LOW.		The battery is almost depleted. Note: Operation of the zoom may interrupt the VIEWCAM power. Replace the battery pack.
		The video heads are clogged and should be cleaned (see page 6).
INSERT A CASSETTE.	CASSETTE	There is no tape cassette in the VIEWCAM. Load a cassette.
CASSETTE NOT RECORDABLE.	PROTECT. TAB	The red erasure protect tab in the video cassette has been slid to the record-protect position, preventing recording.
THE TAPE ENDS SOON.		The tape is about to end. Get ready to load a new cassette.
CHANGE THE CASSETTE.	TAPE END	The tape has reached its end. Load a new cassette.
REPLACE THE LAMP.	REPLACE THE LAMP.	The fluorescent lamp behind the LCD monitor is close to the end of its service life. Replace it with a new one (see page 63). The LCD monitor turns off about 1 minute after this warning is displayed.
		During Self Recording mode, every warning indicator is replaced by a "◇" indicator displayed in the centre of the monitor. To check the meaning of the warning, rotate the monitor back to the normal position.

Note:

• indicates a blinking display.

Setting the Area, Date and Time

Example:

Setting the date to 2 June 1997 (2. 6.1997) and the time to 10:30 am (10:30) in London.

Notes:

- Check that the memory backup lithium battery has been installed before setting the date and time.
- The date and time, once set, are stored in memory.

- 1 Set the Power switch to CAMERA, then press the MENU button until **43** appears on the monitor (Camera mode).

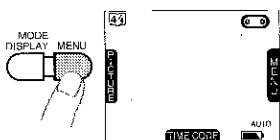

- 2 Press **▶▶** on the Operation button (**F3**) to select "MENU". The MENU-PAGE **41** appears.



Operation button

- If the date and time have been set, the MENU-PAGE **41** appears. Press **▶▶** on the **F3** button to select PAGE **41**.

- 3 Press **■** on the **F3** button to select "AREA" (**1**), then press **◀◀** or **▶▶** until "1 LONDON" appears (**2**).

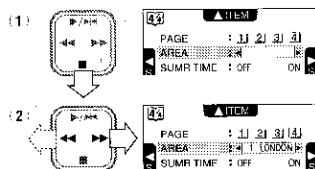

- See the time zone chart on page 54 and the area table on page 55 for area numbers and representative cities for each time zone.

- 4 Press **■** on the **F3** button to select "SETTING" (**1**), then press **▶▶** to select "SET" (**2**):

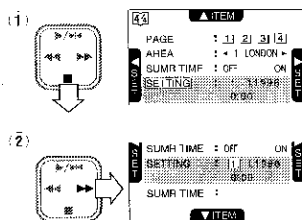

- 5 Press **▶/◀** or **■** on the **F3** button to select "2." (day), and press **▶▶**.

SETTING : 2 1 1996
0:00

- 6 Press **▶/◀** or **■** on the **F3** button to select "6." (month), and press **▶▶**.

SETTING : 2 6 1996
0:00

- 7 Press **▶/◀** or **■** on the **F3** button to select "1997" (year), and press **▶▶**.

SETTING : 2 6 1997
0:00

- 8 Press **▶/◀** or **■** on the **F3** button to select "10" (hour), and press **▶▶**.

SETTING : 2 6 1997
10:00

- 9 Press **▶/◀** or **■** on the **F3** button to select "30" (minutes), and press **▶▶**.

SETTING : 2 6 1997
10:30

The date and time settings are now complete.

To Turn Off the Menu Display

Press the MENU button.

Notes:

- The internal clock starts operating when **▶▶** on the **F3** button is pressed in step 9 above.
- When the tape cassette is inside, if no settings are made within 5 minutes after the menu display appears, the display is automatically cancelled.

Setting the VIEWCAM to Full Auto Mode

This VIEWCAM is equipped with auto focus, auto white balance, auto exposure, and auto shutter speed functions. Set the VIEWCAM to Full Auto mode and you can record high-quality pictures easily.

When "AUTO" is not displayed on the monitor, the VIEWCAM is not in Full Auto mode. Perform the procedure below to set the VIEWCAM to Full Auto mode.

- 1 While the VIEWCAM is in Camera mode, press the MENU button until [34] appears.
Note:
 - If the VIEWCAM is in Manual Focus mode ("FOCUS" selected on the [34] screen), press ■ on the [E] button to return to Auto Focus mode (see page 47).

- 2 Press ►/► on the Operation button ([E]) to select "MANUAL".

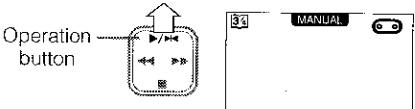

- 3 Select "CAMERA MODE" and then press ◀ on the [E] button to select "AUTO".



- 4 Press the MENU button until [14] appears. "AUTO" is displayed on the monitor. During normal recording, use the [14] screen for the Full Auto mode.

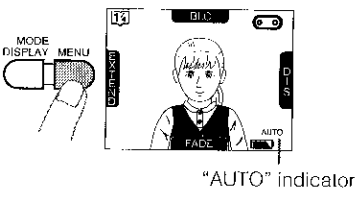

Remaining Recording Time Display

When the VIEWCAM is recording, an on-screen indicator will begin to show how much time you have left, as shown below. You might want to get a new tape ready at this time. To turn off the remaining recording time display, press the MODE DISPLAY button.

MODE DISPLAY button

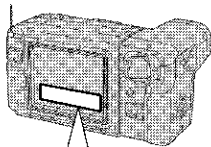

Approx. remaining recording time	Monitor display
Less than half of the tape remaining	
10 min.–8 min.	
8 min.–6 min.	
6 min.–4 min.	
4 min.–2 min.	
2 min.–1 min.	
1 min.–0 min.	<p>THE TAPE ENDS SOON.</p> <p>↓ (after 3 sec.)</p>
0 min. (The tape has reached its end.)	<p>CHANGE THE CASSETTE.</p> <p>↓ (after 3 sec.)</p> <p>TAPE END</p>

Notes:

- The time-remaining indicators only show approximate time left. Also, they vary slightly depending on the length of tape used. (This function's design is based on the DVM60 tape standard.)
- If you press the MODE DISPLAY button to turn off the remaining recording time display, this display will reappear after a short interval to indicate the new time remaining.
- **The time-remaining indicators above appear after 5 seconds from the time you press the REC START/STOP button to start recording.**

Remaining Battery Power Display

When you turn on the VIEWCAM, the remaining battery power display automatically appears on the monitor. By pressing the MODE DISPLAY button, you can turn the display on and off. The remaining power is displayed in five levels, as shown. If the battery power is very low, a warning message will appear. Replace the battery pack.

MODE DISPLAY button

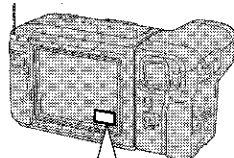

Monitor display	
	(Green)
	(Green)
	(Green)
	(Yellow)
	(Red)

5-level display

BATTERY IS TOO LOW.

↓

Notes:

- Use the remaining battery power display only as an indication.
- Battery consumption may vary depending on the condition of use.
- The battery power display may change to either a higher or lower level if you set the Power switch to OFF and then back to CAMERA or VCR again.
- Use of the zoom functions when the warning message "BATTERY IS TOO LOW." is displayed may cause the VIEWCAM to suddenly lose power. Replace the battery pack.
- Remaining battery power display will not be displayed when the VIEWCAM is powered from an AC outlet or a car battery.

Basic Operations Camera Recording

- Refer to pages 21–23 on how to operate the monitor display.

Unlike conventional camcorders, this model frees you from having to peer into a small viewfinder. You can watch the subject on the large LCD monitor screen for easier, more enjoyable video-shooting.

Easy Camera Recording with Full Auto

Before you start recording, perform the operations described on pages 13 through 27 to prepare your VIEWCAM for recording.

- 1 Hold down the lock button and slide the Power switch to CAMERA.
 - The picture from the lens is now displayed on the LCD monitor.

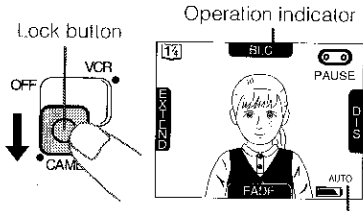

"AUTO" appears.

- 2 Press the REC START/STOP button to start recording.

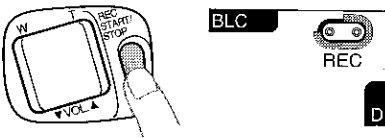

Note:

- When you set the Power switch to CAMERA, it may take some time before the screen appears. Wait until the screen appears, then start operation.

To Pause Recording

Press the REC START/STOP button again. Recording pauses, and the VIEWCAM enters Recording Standby mode.

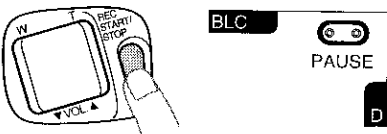

To Turn the Power Off

Slide the Power switch to OFF without pressing the Lock button.

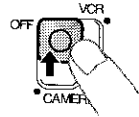

Notes:

- To leave Camera Recording mode, set the Power switch to OFF.
- During Camera Recording mode, the speaker is off, and the PHONES (earphones) jack cannot be used.
- If the VIEWCAM is kept in Recording Standby mode for more than approximately 5 minutes, the power will automatically turn off to save battery power and to protect the tape from being damaged. To continue recording after this, set the Power switch to OFF, and then back to CAMERA again.
- If you will not be recording again for a while, turn the power off. This will make the battery last longer.
- The operation indicators can be turned off or back on again with the MODE DISPLAY button.
- The date and time, once set, will be internally recorded even if they do not appear on the screen. You can also turn them on or off on the screen. See page 54 for details.

Maximum Time for Continuous Camera Recording and Playback

Battery pack	Max. camera recording time	Max. playback time
BT-L2	Approx. 50 min.	Approx. 50 min.

Notes:

- The use of the zoom and other functions will accelerate power consumption. The actual recording time per battery pack may be 30%–50% less than the maximum camera recording time shown above.
- The above playback time is based on operation of the VIEWCAM without use of the A/V pack and with the volume set at the middle setting.

Basic Operations

Camera Recording

Zooming

Zooming allows you to move visually closer to or farther from a subject without physically changing your position.

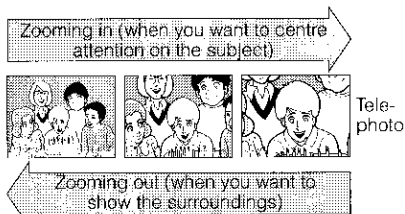

To Zoom In

Press the Power Zoom T (telephoto) button to get a close-up view (i).

To Zoom Out

Press the Power Zoom W (wide angle) button to get a wide field of view (i2).

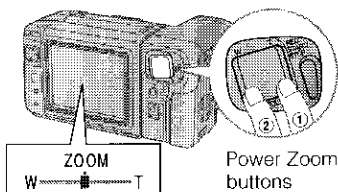

- The zoom speed changes depending on the degree of pressure placed on the Power Zoom buttons.
- The on-screen display will show you the current zoom setting.

Notes:

- The VIEWCAM is unable to focus when zooming in on subjects within 1.5 m. The VIEWCAM will automatically zoom out until it focuses on the subject.
- Frequent zooming produces unattractive pictures. It also increases battery power consumption.

Setting the Digital Zoom

You can select between two different zoom ranges by setting the "DGTL ZOOM" menu item to "ON" or "OFF": 1-12x optical zoom ("OFF") or 12-30x digital zoom ("ON"). The 12-30x digital zoom allows you to record powerful close-up pictures with the same operation as normal zooming. The zoom range is factory preset to 1-12x optical zoom. In the 12-30x zoom range, the picture quality may suffer slightly.

- 1 Press the MENU button until **4** appears on the monitor (Camera mode).

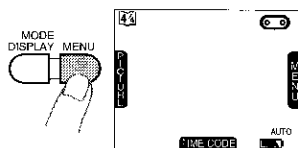

- 2 Press **▶▶** on the Operation button (**⏪**) to select "MENU".

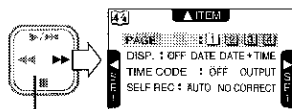

Operation button

- 3 Press **▶▶** on the **⏪** button to select MENU-PAGE **12** (i), then press **■** to select "DGTL ZOOM" (i2).

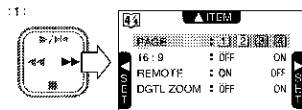

- 4 Press **▶▶** to select "ON".

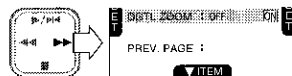

- 5 The digital zoom is now on. Press the MENU button to turn off the menu.

To return to normal zoom, set "DGTL ZOOM" to "OFF" in step 4 above.

Note:

- When the digital zoom is used, the picture quality may suffer. At maximum zoom, the horizontal resolution decreases by a maximum of 60% of the optical zoom.

Digital Quick Zoom (Extend Zoom)

Use the digital quick zoom function (extend zoom) to instantly zoom in on a subject. This is useful when you want to instantly capture a particular subject.

Using Digital Quick Zoom (Extend Zoom)

1 Press the MENU button until appears on the monitor (Camera mode).

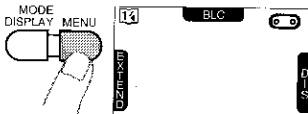

2 During recording, press on the Operation button () to select "EXTEND" when you want to instantly zoom in on a subject.

Operation button

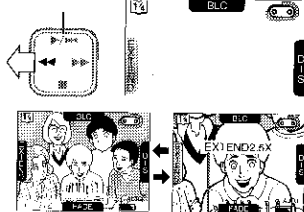

"EXTEND 1.5x", "EXTEND 2.0x" or "EXTEND 2.5x" is displayed.

To return to the previous magnification, press on the button to select "EXTEND" again.

Notes:

- When the digital quick zoom is used, the picture quality decreases by a maximum of 60% of the optical zoom.
- The digital quick zoom (extend zoom) function does not work in the digital zoom (12-30x) range. ("EXTEND" is faintly displayed.)
- When the extend zoom is on with the optical zoom at 12x, 1.5x becomes 18x, 2.0x becomes 24x, and 2.5x becomes 30x.

Setting the Digital Quick Zoom Ranges

Refer to page 22 to display MENU-PAGE [3], and then press on the Operation button () to select "EXTEND ZOOM". Press or on the button to select "1.5", "2.0" or "2.5" x.



Auto Focus

The auto focus feature is designed to focus on most types of subjects. In Auto Focus mode, the VIEWCAM automatically focuses on whatever is in the centre of the scene. Always keep the subject in the centre of the screen. The auto focus may not be able to focus on the subject in the situations shown in the chart. In such situations, set the VIEWCAM to Manual Focus mode and focus manually (see page 47).

Subject is too dark.	Lack of contrast, e.g. snow scene.
Fast moving subject.	Background is too bright.
Subject has vertical or horizontal stripes.	Subject is being shot through a dirty or wet window.
Light reflects off the subject.	Two subjects at different distances overlap in the same scene.
Subject has fine, repeated patterns	Subjects at different distances appear in the centre of the scene at the same time.
High speed shutter being used under fluorescent lighting.	

Notes:

- If no subject is in the centre of the monitor, the focus area will expand and the subject nearest the centre will be focused on.
- If no subject is displayed on the monitor, the VIEWCAM will automatically zoom out until some subject comes into the frame.
- If the image being recorded is not sharp, the auto focus may not function and the image will be blurred. If this occurs, press the Power Zoom W button to zoom out, or pan the VIEWCAM to shoot some other subject. The auto focus will resume operation.

Backlight Compensation (BLC)

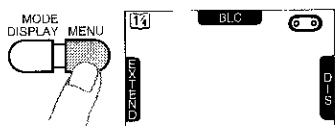

When the subject is backlit, the image will be darkened if it is recorded normally. Use the backlight compensation (BLC) feature to improve the picture.

- 1 Press the MENU button until  appears on the monitor (Camera mode).





Note:

- At locations where lighting is insufficient, "LIGHT" appears on the monitor. "GAIN-UP" instead of "BLC" appears indicating the BLC function cannot be used.

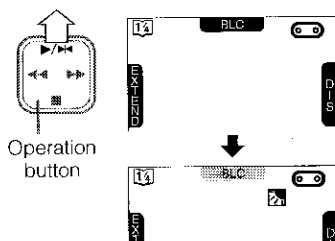
- 2 Press  on the Operation button () to select "BLC". The backlight compensation indicator  appears on the monitor, indicating that the BLC function is now working.



To turn off the BLC function, press  on the  button to select "BLC" again. The "" indicator goes off.

Gain-up (Cat's Eye)

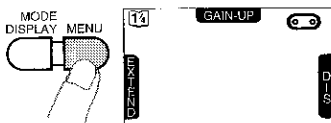

When you are recording in a dark or poorly illuminated location, "LIGHT" (warning of too little ambient illumination) is displayed on the monitor. Use the gain-up feature to record a brighter picture.

- 1 Press the MENU button until  appears on the monitor (Camera mode).





Note:

- At locations where lighting is adequate, the "LIGHT" indicator will not appear. "BLC" instead of "GAIN-UP" appears indicating the gain-up function cannot be used.

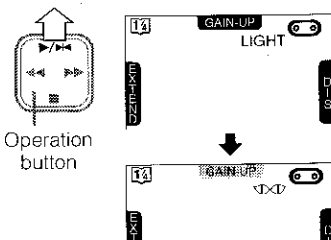
- 2 Press  on the Operation button () to select "GAIN-UP". The "LIGHT" display changes to the gain-up (cat's eye) display "", indicating that the gain-up function is now working.



To turn off the gain-up function, press  on the  button to select "GAIN-UP" again. The "" display changes to the "LIGHT" display.

Notes:



- If the VIEWCAM is moved to a bright location after it is engaged in Gain-up mode, the Gain-up mode will disengage automatically.
- There is more picture noise in Gain-up mode.

Digital Image Stabilization (DIS)

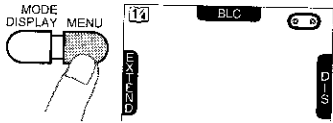

The DIS function lets you stabilize the image by electronically cancelling relatively small image shakes that are often annoying in close-up shots.

- 1 Press the MENU button until  appears on the monitor (Camera mode).

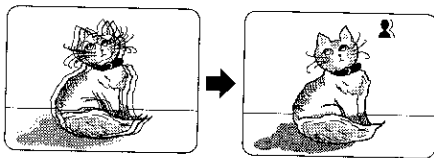
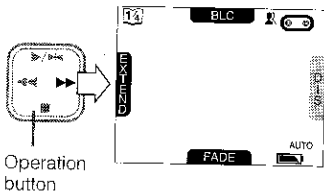

- 2 Press  on the Operation button () to select "DIS". The "DIS" indicator appears on the monitor, and the VIEWCAM enters DIS mode.



To return to normal recording mode, press  on the  button to select "DIS" again. The "DIS" indicator will disappear.

Notes:

- While this function is in progress, the image on the monitor is slightly magnified, and the shutter speed is automatically switched from the standard speed (1/50 sec.) to 1/120 sec.
- Image resolution slightly decreases in DIS mode.
- Under the light of fluorescent lamps, the picture may brighten and dim.
- The DIS feature does not work during Still Recording mode.
- Battery consumption is larger in DIS mode. We recommend that you not use the DIS feature when using the VIEWCAM on a tripod.

Caution:

- The DIS function cannot compensate for excessive image shake, or for the subjects or situations described below.
 - Subject with low contrast*
 - Subject with a plain background*
 - Dark or dimly lit subject*
 - Subject with vertical or horizontal stripes
 - Many moving subjects in a single frame (*The "DIS" indicator blinks during these conditions.)

Macro Shots

This VIEWCAM lets you shoot close-up images of small objects such as flowers and insects, or make title frames for your videos. When you want to record a magnified image of a subject which is within approximately 1.5 m of the VIEWCAM, do not zoom in on the subject. Instead, zoom out all the way by holding down the Power Zoom W button, and then move the VIEWCAM closer to the subject until you obtain the desired angle of view. The VIEWCAM will automatically focus on the subject when the lens is set for the widest angle.

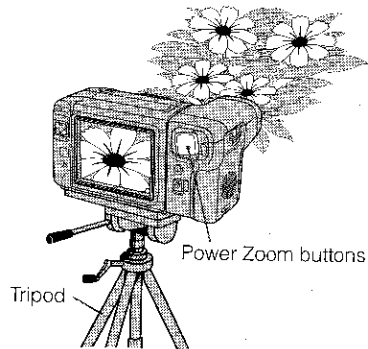

Notes:

- When you are recording a macro shot, be sure that the subject receives sufficient illumination.
- It is recommended that you use a tripod for recording macro shots, to prevent image shake.
- Before you mount the VIEWCAM on a tripod, be sure to connect the supplied tripod adaptor to the VIEWCAM (see page 19).

Tips on Recording Positions

The rotating LCD monitor screen lets you enjoy easy video recording in relaxed postures.

- You can record using more natural body postures since you can see the subject on-screen, without having to hold the VIEWCAM against your eye.
- The LCD monitor also makes high-angle and low-angle shots easy.
- In hand-held recording, the VIEWCAM has to be steadied to prevent image shake.
- Use a tripod for very stable recording.

Basic Recording Positions

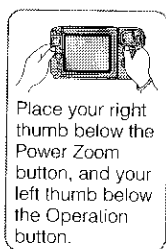

Place your right thumb below the Power Zoom button, and your left thumb below the Operation button.



Basic Posture

Look at the monitor with both eyes.

Press your elbows against your sides.

Place your feet at a 45° angle and take a firm stance.



High Angle

You can record and still see the monitor screen. This is convenient when you want to record over a crowd.

Self Recording

Rotate the monitor 180°.



This is useful when you want to record your own portrait by yourself, or record yourself and your friends together.

Low Angle

When kneeling, put one knee on the ground for the best stability.



Prone

Rest on both elbows to stabilize the VIEWCAM.

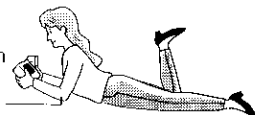

Notes:

- Take care not to touch the monitor screen with your fingers, as perspiration and dirt will smudge it.
- Unless you intend to create a special effect, keep the VIEWCAM level with the horizontal plane.
- Take care not to touch the microphone with your fingers when the VIEWCAM is recording. It will cause noise on the audio track.

Hints for Better Shooting

- Position the subject in the centre of the screen. When you are using auto focus, whatever is in the centre of the screen is kept in focus.



Position the subject in the centre.

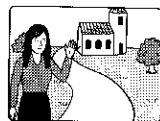

Focus manually when you need to position the subject off centre (see page 47).

- Avoid backlit subjects. For the best picture, have the light source behind you. When the background is brighter than the subject, the subject often becomes too dark. If you need to record with this lighting, correct the gain or iris to improve the picture (see pages 31 and 50).

Light from behind



Back-lighting

- Before zooming, think about how to best frame the shot. Stop zooming when the shot is well framed.
- When image shake is noticeable during zoomed-in telephoto shooting, use a tripod, or press the Power Zoom W (wide angle) button to zoom out. (See page 19 for the use of the tripod adaptor.)
- Horizontal panning (lateral movement) and tilting (vertical movement) should be done slowly to emphasize the wide expanse of a scene or the height of a building, and to make them easy to watch on playback.
- Use wide-angle settings for fast-moving subjects.

Note:

- It may take longer to focus when zooming and panning are used frequently.

Basic Operations Playback

- Refer to pages 21–23 on how to operate the monitor display.

Playback

The LCD monitor makes it possible to play back and see what you have just recorded. Nothing needs to be connected, allowing instant on-screen playback. You can hear the sound through the built-in speaker or via your own stereo earphones.

- 1 Hold down the Lock button and slide the Power switch to VCR.

- It may take some time before the screen appears. Wait until the screen appears, then start operation.

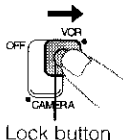

- Stereo earphones with a 3.5 mm diameter plug can be plugged directly into the PHONES jack. When you use this jack, the speaker automatically turns off.

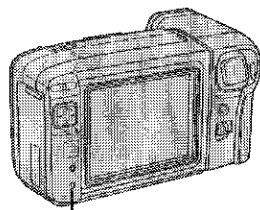

PHONES jack

Caution:

- To use the remote control, make sure that the remote control menu item ("REMOTE") is set to "ON". The remote control cannot be used to operate the VIEWCAM when this is set to "OFF". See page 43.

- 2 Press the MENU button until appears on the monitor.

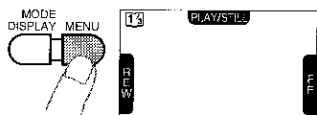

- 3 If the tape is not at the desired point, press or on the Operation button () to select "FF" (Ⓛ) or "REW" (Ⓜ).

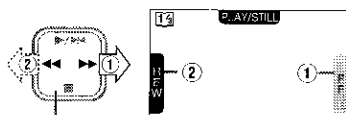

Operation button

- 4 Press to select "PLAY".

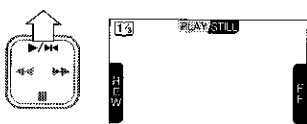

Volume Control

While the VIEWCAM is in the VCR mode, press the VOL. or button to increase or decrease the volume to your preference.

The volume control indicator will appear on the monitor. After adjusting the volume, if the Volume control buttons are not pressed, the indicator will disappear after a short time.

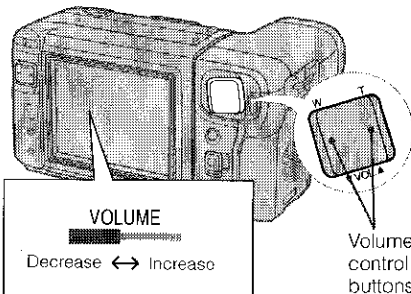

Volume control buttons

Note:

- The volume can also be adjusted with the remote control.

To Stop Playback

Press on the button to select "STOP".

Auto Tape Rewind

The tape is automatically rewound when playback reaches the end of the tape.

Notes:

- If you wish to turn off the operation indicators on the monitor (e.g. because they interfere with your view of the picture), press the MODE DISPLAY button. The buttons will still function as indicated even after their indicators are turned off.

Fast Forward and Rewind

During a stop mode, press or on the button to select "FF" (Fast Forward) or "REW" (Rewind) on the screen (VCR mode).

Displaying the Date and Time of Recording

The date and time, once set, are stored in memory. You can display them on the monitor during playback even if they were off during recording.

- 1 Display the menu screen (VCR mode) using the MENU button and the Operation button (⏏).

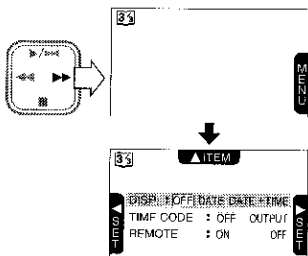

- 2 Select "DISP." and set it to "DATE" or "DATE+TIME" using the ⏏ button.

Notes:

- You can also display the date and time by pressing the DATE DISPLAY ON/OFF button on the remote control. (When the tape is not running, the current date or time will be displayed.)
- If you wish to display the date and time during playback, make sure, before recording, that the date and time have been set correctly. If they are not set, "----:" will be displayed. This will also be displayed on blank or damaged portions of the tape.

Video Search

This function makes it easy for you to search for a scene near the current tape position.

- 1 During playback, press ⏏ on the Operation button (⏏) to select "FF" (:1:) (or ⏏ to select "REW" [:2:]) on the ⏏ screen (VCR mode). The fast forward (or reverse) playback picture is displayed on-screen.

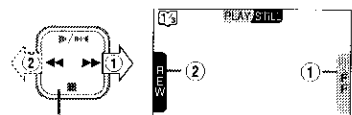

Operation button

- 2 When you find the desired scene, press ⏏ on the ⏏ button to select "PLAY" to return to normal playback.

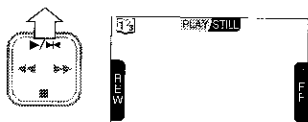

Notes:

- The sound is off during search.
- Some picture noise appears during search. This is not a malfunction.

Still

This function makes it possible to freeze the picture. During playback, press ⏏ on the ⏏ button to select "STILL" on the ⏏ screen (VCR mode). To return to normal playback, press ⏏ to select "STILL" once again.

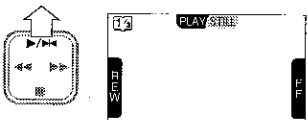

Slow

This function makes it possible to play back in slow motion. During playback, press the SLOW button on the remote control. To return to normal playback, press PLAY button on the remote control to select "PLAY".

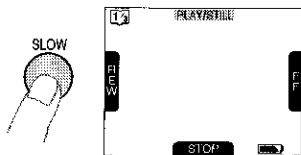
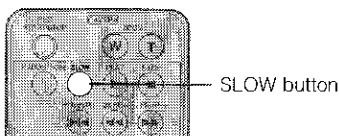

Notes:

- The sound is off during Still and Slow modes.
- To protect the tape, the VIEWCAM automatically returns to ordinary playback if it is left in Still mode for more than 5 minutes or in Slow mode for more than about 40 seconds.
- Still image playback can also be operated with the remote control. (See page 43.)
- If still or slow functions are used when connected to a TV, noise will appear and distort the image.
- Slow function cannot be operated from the VIEW-CAM.

Frame Advance

During **still picture playback**, press the F.ADV/STROBE button on the remote control. Each time you press the button, the picture advances one frame.

To return to normal playback, press the PLAY button (▶).

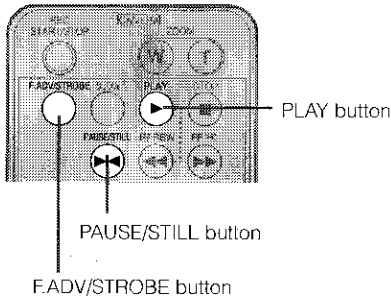

Basic Operations
Playback

Strobe Playback

During **normal playback**, press the F.ADV/STROBE button on the remote control. The VIEWCAM plays back one frame at a time at approximately 1/4 sec. intervals.

To return to normal playback, press the PLAY button (▶).

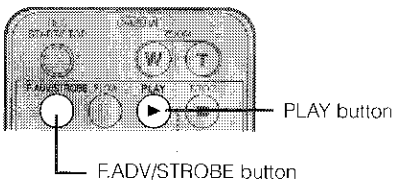

Note:

- Frame advance and strobe playback functions cannot be controlled from the VIEWCAM.

Turning Off the LCD Monitor Backlight

This VIEWCAM's LCD monitor uses a fluorescent lamp for backlighting (see page 63). In order to reduce battery consumption, you can turn off the lamp when backlighting is not necessary (e.g. when you are watching a playback on a connected TV's screen).

While the VIEWCAM is in Camera or VCR mode, hold down the MODE DISPLAY button for more than 5 seconds. The backlight will turn off and the LAMP OFF indicator will light up. To turn it on again, press the MODE DISPLAY button, or set the Power switch to OFF and then back to CAMERA or VCR.

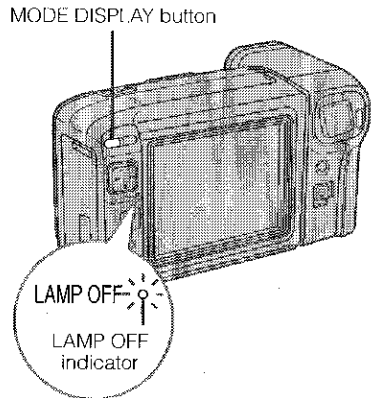

Notes:

- The LAMP OFF indicator will blink when the monitor is off to indicate that there is a warning message. Press the MODE DISPLAY button and check the message on the monitor.
- Turning the LCD monitor on and off repeatedly may deplete battery power.

Programme Search

The programme search feature automatically finds the beginning of a number of previously recorded scenes. Up to 10 different scenes can be found on one tape.

- 1 Set the Power switch to VCR.

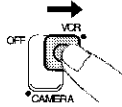

- 2 Press the MENU button until [23] appears on the monitor.

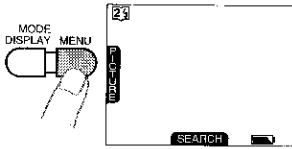

- 3 Press [] on the Operation button ([]) to select "SEARCH". The VIEWCAM enters the Programme Search mode. Both the "REW" and "FF" indicators, or one of them will start flashing. To cancel, press [] to select "SEARCH" again.

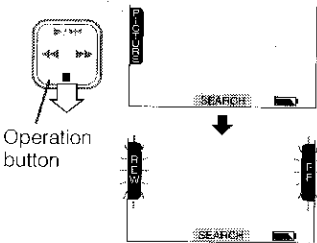

- 4 Press [] on the [] button to select "REW" (or [] to select "FF"). "SEARCH" will start flashing. The tape rewinds (or fast forwards) to the beginning of a scene immediately before (or after) the current tape position; playback then starts automatically. The "REW" and "FF" indicators automatically disappear after about 10 seconds.

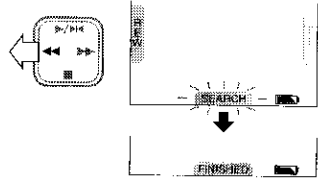

- 5 To continue searching, press [] to select "REW" (or [] to select "FF") while its indicator is displayed.

Notes:

- Use this feature when the tape is stopped or being played back.
- This function finds the beginning of the scene immediately before or after the current tape position, stopping at every scene. It is not possible to skip a scene.
- This function cannot spot recordings that are shorter than 10 seconds in length.
- In steps 3 and 5, if the tape is at a point ahead of the most recent recording, only the "REW" indicator will flash, and the "FF" indicator will not appear.
- In steps 3 and 5, if the tape is at a point before the oldest recording, only the "FF" indicator will flash, and the "REW" indicator will not appear.
- This feature does not function if no recording has been made since the cassette was loaded, or if the cassette has been removed after the recordings were made. "SEARCH" is faintly displayed in this case.

Basic Operations Playback

Example: To find the beginning of five different scenes.

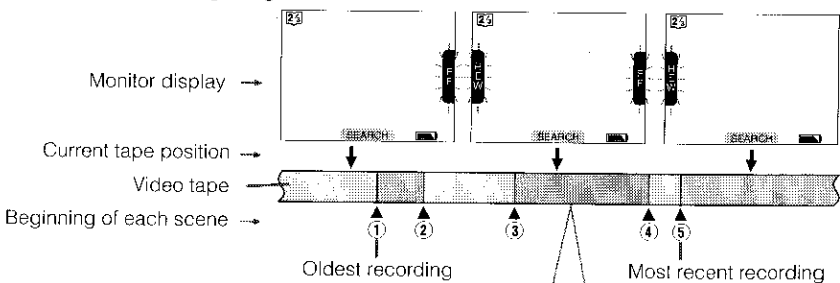



When you are at this position,
 Press [] on the [] button to select "REW" to rewind the tape to [] and begin playback.
 Press [] on the [] button to select "FF" to forward the tape to [] and begin playback.

Using the Time Code

The time code allows you to record images together with the hour, minute and second of recording, and the frame number (1 frame = approx. 1/25 sec.). This can be displayed on the screen when needed, and used as an accurate counter.

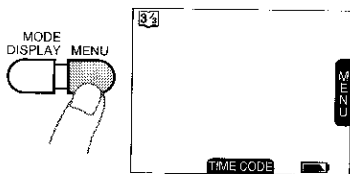
- 1 Press the MENU button until  appears (VCR mode).



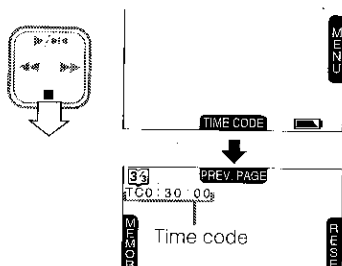

- 2 Press  on the Operation button () to select "TIME CODE". The time code display appears.



When images are played back in Still or Frame Advance mode, the time code is displayed for each frame. (During normal playback, only the hour, minute and second are displayed.)



To turn off the time code display, press  on the  button again.

Displaying the Time Code with the Remote Control

Press the Time Code DISPLAY ON/OFF button on the remote control to display and turn off the time code.

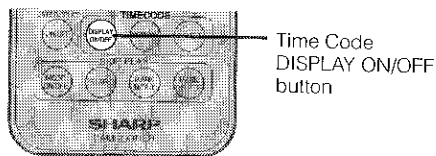

Displaying the Time Code on Your TV During Playback

- 1 Display the menu screen (VCR mode) on the monitor using the MENU button and the  button.

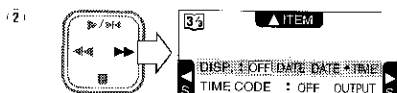
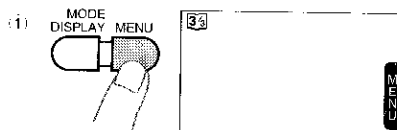

- 2 Select "TIME CODE" and set it to "OUTPUT" using the  button. (See pages 22 and 23 for menu setting.)

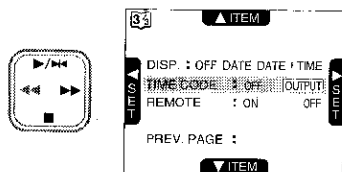

Notes:

- When the tape reaches an unrecorded section, the time code returns to zero (TC 0:00:00). Once recorded, the time code cannot be changed.
- The time code will remain displayed even if you press the MODE DISPLAY button to turn off the on-screen display.

Using the Tape Counter

Use the tape counter feature when you want to know the playback or recording time.

- 1 Press the MENU button until **33** (VCR mode) or **44** (Camera mode) appears on the monitor.

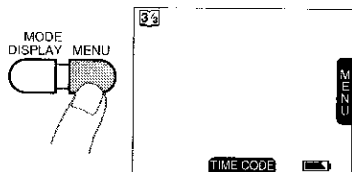

- 2 Press **■** on the Operation button (**⏮**) to select "TIME CODE". The time code display appears.

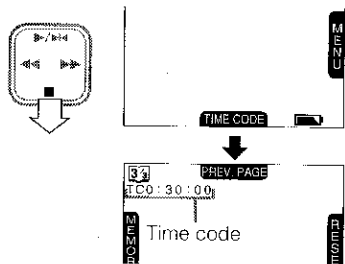

- 3 Press **▶▶** on the **⏮** button to select "RESET". The time code display changes to the tape counter.

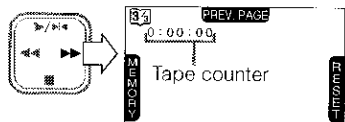

- 4 Begin recording or playback. You can check the recording or playback time on the monitor.

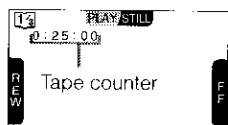

Counter Memory

Use the counter memory when you want to return to the beginning of a particular scene. The position where the counter memory is reset (0:00:00) is stored in memory to make it easier to return the tape to that point.

- 1 During playback or recording, display the time code on the monitor.
- 2 Press **◀◀** on the **⏮** button to select "MEMORY". The time code display changes to the counter memory display.

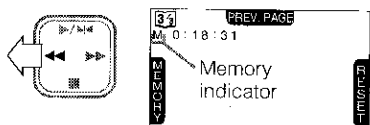

- 3 Press **▶▶** to select "RESET" at the beginning of a scene you want to return to later. The counter is reset to "M 0:00:00".

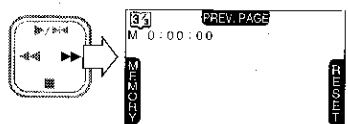

- 4 Stop the tape after playback. If you have been recording, stop the tape and set the Power switch to VCR.
- 5 Rewind the tape. The tape will automatically stop when the counter reaches 0:00:00.
- 6 Start playback to view the desired scene.

To cancel the Counter Memory mode

Repeat step 1 and press **◀◀** on the **⏮** button to select "MEMORY". The counter memory display will change to the normal time code display.

Notes:

- The Fast Forward function can be used in the same way.
- This function does not work during video searches.
- In step 5 above, the tape may stop slightly ahead or behind the point where you reset the counter to "M 0:00:00".

Skip Playback

This feature automatically skips unwanted sections during playback. Use the SKIP PLAY operation buttons on the remote control to perform skip playback.

Remote control

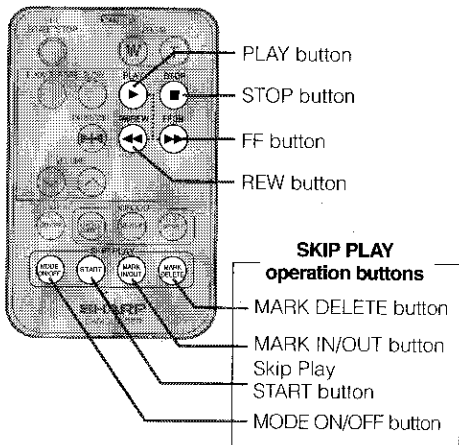

- 1 Set the Power switch to VCR.

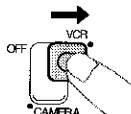

- 2 Press the Skip Play MODE ON/OFF button on the remote control. The VIEWCAM enters the Skip Play mode, and "SKIP PLAY" is displayed on the screen.



- 3 During playback, press the MARK IN/OUT button at the beginning of the section you wish to skip. The "SKIP PLAY" display changes to "MARK IN", which then changes to the flashing "MARK OUT" display after about five seconds.

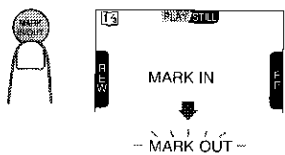

- 4 Press the MARK IN/OUT button at the end of the section you wish to skip. The "MARK OUT" display changes to "SKIP PLAY" after about five seconds.



Note:

- Repeat steps 3 and 4 to skip additional scenes.

- 5 Rewind the tape to the beginning of the playback section.
- 6 Press the Skip Play START button on the remote control. Skip playback starts. During the skipped section, "SEARCH MARK" flashes on the screen.

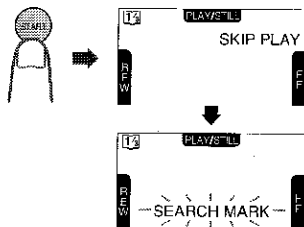

To stop skip playback

Press on the Operation button (⏏) or press the STOP button on the remote control.

To disengage the Skip Play mode

Press the Skip Play MODE ON/OFF button on the remote control. The "SKIP PLAY" display disappears.

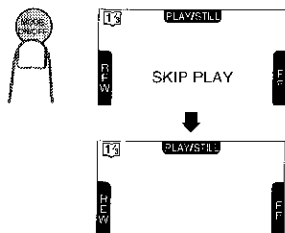

Deleting Skip Marks

- 1 In Skip Play mode, rewind or fast forward the tape to the beginning of the section with a skip mark.

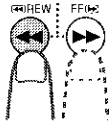

- 2 Press the PLAY button to start playback.



- 3 When "MARK IN" or "MARK OUT" is displayed, hold down the Skip Play MARK DELETE button for two seconds.
 - The red "DELETE MARK" display will appear on the monitor, and the skip mark will be deleted. The red "DELETE MARK" display will then disappear, and the white "SKIP PLAY" display will appear on the monitor.

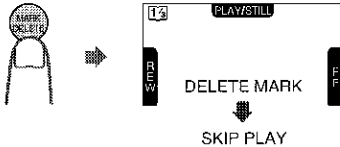

Note:

- This VIEWCAM uses two standardized DV (digital VCR) signals, Skip ID and Index ID, for skip playback. When deleting skip marks, Skip ID and Index ID signals pre-recorded on the tape may also be deleted.

To change a skipped section

Delete the skip mark to be changed, then add new skip marks, following steps 3 and 4 on page 41.

Notes:

- The SKIP PLAY operation buttons work only after the MODE ON/OFF button is pressed to engage the Skip Play mode.
- Leave about ten seconds between skip marks. If the interval between skip marks is less than ten seconds, the skip playback function may not operate correctly during playback.
- The skip playback function will not work with tapes recorded with camcorders other than this VIEWCAM.
- Skip marks cannot be added to a tape if the erasure protect tab is in the "SAVE" position.
- Fast forward and other functions cannot be used while the MARK IN/OUT signals are being recorded (approx. 5 sec. after the MARK IN/OUT button is pressed).

Example of Skip Playback

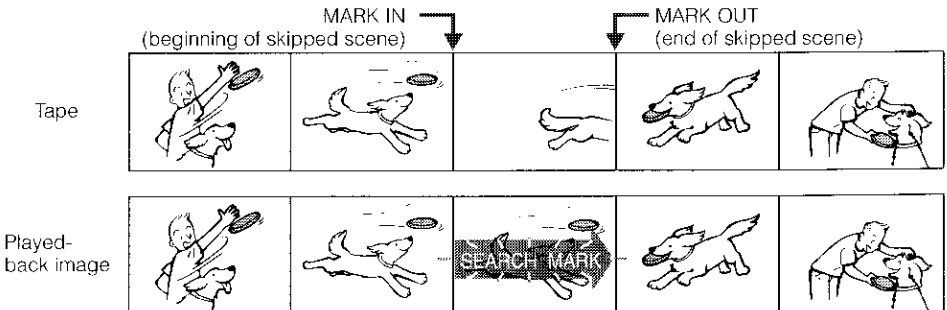

During search, a still image of the last scene is displayed.

Using the Infrared Remote Control

Use the remote control to operate the VIEWCAM from a distance, such as when you want to record yourself in a scene, or when the VIEWCAM is connected to a TV for use as a VCR.

- 1 Set the Power switch to CAMERA or VCR.

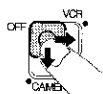

- 2 Press the MENU button until **44** (Camera mode) or **33** (VCR mode) appears on the monitor.

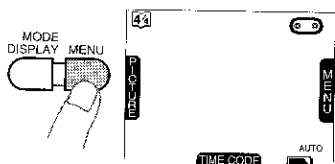

- 3 Press **▶▶** on the Operation button (**▶▶**) to select "MENU".

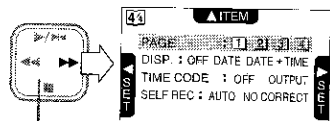

Operation button

- 4 Press **▶▶** on the **▶▶** button to select MENU-PAGE **2** (1) and then press **■** to select "REMOTE" (2).

Make sure that "REMOTE" is set to "ON".



If "REMOTE" is set to "OFF", press **◀◀** to select "ON".

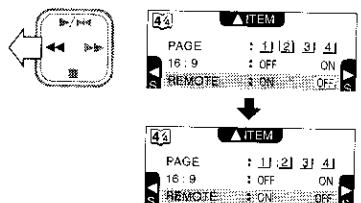

- 5 Aim the remote control at the photoreceptor of the VIEWCAM, and press the control buttons for operation.

Approximate operating range of remote control

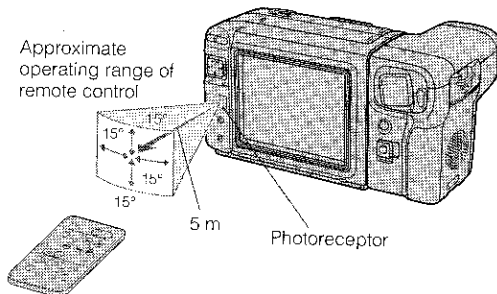

Notes:

- Be careful not to allow direct sunlight or bright light from interior illumination to fall onto the VIEWCAM's photoreceptor, as this may prevent the remote control from operating properly.
- Be sure that there are no obstacles between the remote control and the VIEWCAM's photoreceptor.
- When the "REMOTE" setting is changed in either Camera or VCR mode, the setting for the other mode is automatically set to the same.
- The lithium battery normally lasts about one year. It can be shorter under some operating conditions. When the lithium battery is dead and the remote control does not operate, replace the battery with a new one following the instructions on page 13.
- The **▶▶**, **▶**, **■**, **◀**, or **◀◀** buttons on the remote control cannot be used to move the cursor, or select or set any of the various functions on the monitor.

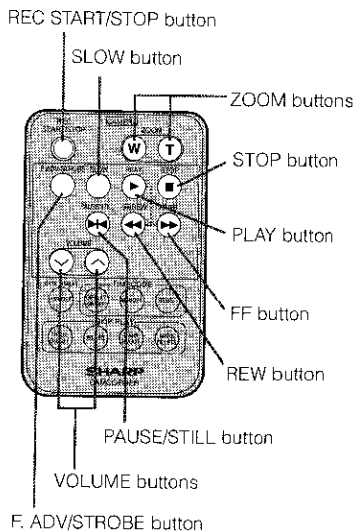

Useful Features for Camera Recording

Self Recording

The LCD monitor can be rotated 180° vertically so that the monitor screen faces the subject. This lets you record yourself while watching yourself on the screen.

Enjoy recording your own portrait by yourself, or recording yourself and your friends together at a party.

Example of Recording in Self Recording Mode

Tripod adaptor for 180° recording VR-33FA (optional accessory)



Recording yourself and your friends together at a party, using the remote control, while monitoring yourselves on the VIEWCAM's screen.

Cautions:

- Do not rotate the monitor to the self recording position while the VIEWCAM is recording or playing back.
- For recording in Self Recording mode, be sure to rotate the monitor, NOT the lens. If you hold the VIEWCAM upside down with its lens at the bottom, the subject will be recorded upside down.

Normal Self Recording

- 1 Rotate the VIEWCAM's monitor section 180° vertically. The VIEWCAM will show a mirror image of the subject. Playback image will not be reversed even though the monitor shows the mirror image during self recording.

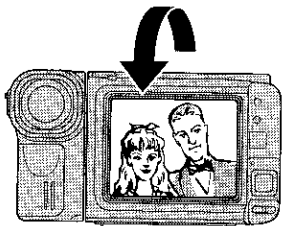

Note:

- If the image on the monitor is upside-down, return the monitor to the normal position and display MENU-PAGE 1 (Camera mode). Press **■** on the Operation button (①) to select "SELF REC" (②) and then press **◀▶** to select "AUTO" (③).

Operation button

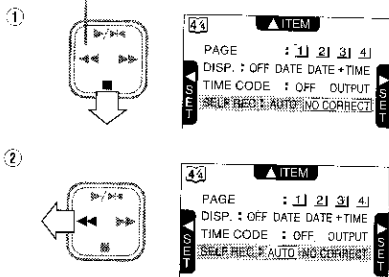

- 2 Press **◀▶** to select "WIDE" or "TELE".

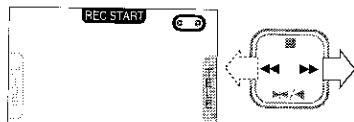

- 3 Press **■** to select "REC START".

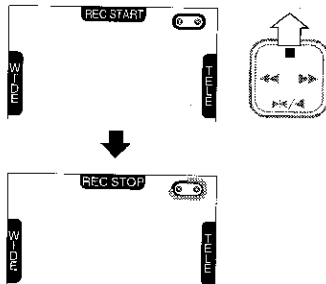



To pause recording, press **■** on the **⏏** button.



Self Recording Message OSD

In Self Recording mode, by following some simple instructions that appear on the monitor screen, you can easily record a short video message for somebody. This feature is especially convenient for editing video letters.

- Perform step 1 of "Normal Self Recording" on page 44, then perform the procedure below.

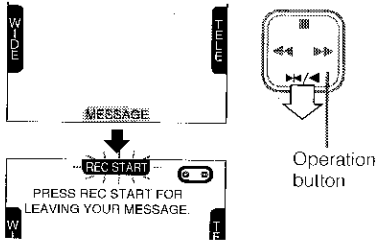
- 1 Press  on the Operation button () to select "MESSAGE". The instruction "PRESS REC START FOR LEAVING YOUR MESSAGE." appears on the monitor, and the "REC START" indicator starts flashing.



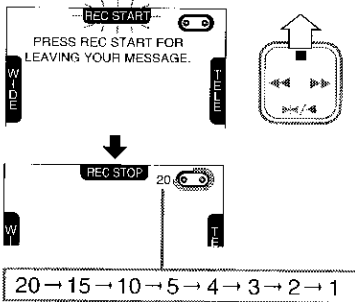

- 2 Press  on the  button to select "REC START". Say your message while facing the lens of the VIEWCAM.

- The recording time is preset for 20 seconds.
- The remaining number of seconds is displayed in the upper right hand corner of the monitor screen.



(remaining number of seconds)



- 3 When the remaining recording time reaches 5 seconds, "EXTEND" will flash.
 - When you want to extend the recording time, press  on the  button to select "EXTEND" within 5 seconds. After pressing the button, you may record continuously for 10 more seconds.

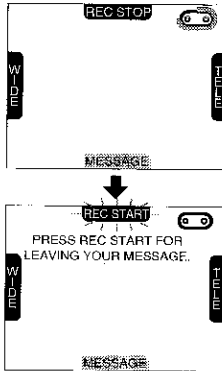

- 4 At the end of recording, the screen fades out, and recording stops automatically. The VIEWCAM returns to Recording Standby mode, and "PRESS REC START FOR LEAVING YOUR MESSAGE." appears again on the monitor screen.



Note:

- When you want to stop recording before message recording stops automatically, press  on the  button to select "REC STOP". The screen fades out immediately and the VIEWCAM returns to Recording Standby mode.

More Information on Self Recording

- The screen image is automatically inverted when the monitor rotation is between 140° and 200°. When the monitor is turned back to the normal position, the image returns to normal.
- During Self Recording mode, only the REC START/STOP, Zoom Wide and Telephoto buttons function on the remote control (see page 43).

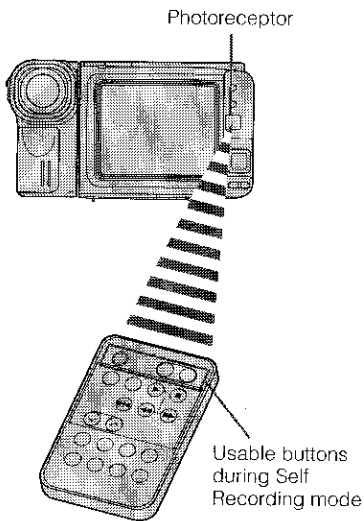

- In Self Recording mode, all standard warning indicators on the monitor are replaced by a flashing "◇" indicator. To check the meaning of the warning, turn the monitor back to the normal position.

- In Self Recording mode, it is not possible to record using manual recording modes, change picture adjustments, display menus, record the date and time, or use the quick return and some of the other features.

- You can begin playback by setting the Power switch to VCR, even while the monitor is rotated 180°. The functions displayed on the monitor during normal playback still operate even though not displayed. (For example, ►/◄ on the Operation button [RECALL] works as the Play button.)

After recording in Self Recording mode, you can enjoy instant playback without having to re-rotate the monitor. In this case, the indicators will not be displayed on the monitor.

- If you set "SELF REC" to "NO CORRECT" on MENU-PAGE [1] (Camera mode), the image on the monitor screen will be displayed upside down.

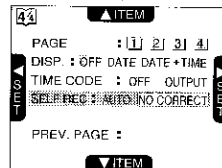

Manual Focus

The auto focus may not be able to focus on the subject in the situations shown in the chart on page 30. In such situations, set the VIEWCAM to Manual Focus mode and focus manually.

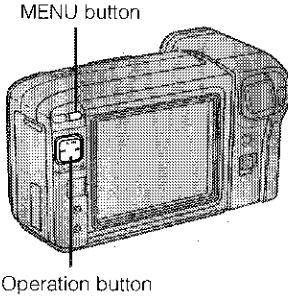

Setting the Manual Focus

- 1 Press the MENU button until 34 appears on the monitor (Camera mode). Press ■ on the Operation button () to select "FOCUS".

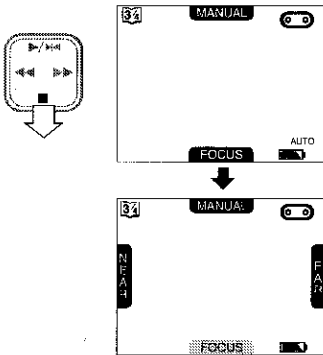

- 2 Press ◀ or ▶ on the button to select "NEAR" or "FAR".

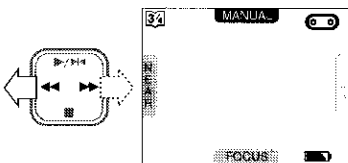

To Return to Auto Focus Mode

Press ■ on the button to select "FOCUS" in step 1.

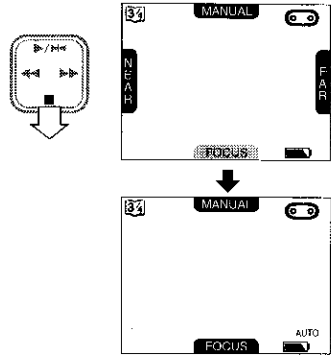

Notes:

- When recording in the Manual Focus mode, you may not be able to focus correctly if the subject is within approximately 1.5 m of the VIEWCAM. In such a case, shift the zoom control toward wide angle, and then try focusing again.
- If you focus on a subject in wide angle and then set the zoom to maximum, the subject may go out of focus. First focus on the subject at maximum zoom setting and then shoot at the desired zoom setting.
- If the lens is dirty or fogged, you may not be able to obtain correct focus.

Setting the Shutter Speed

MENU button

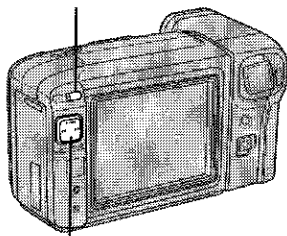

Operation button

- 1 Press the MENU button until **34** appears on the monitor (Camera mode). Press **▶/▶▶** on the Operation button (**34**) to select "MANUAL".

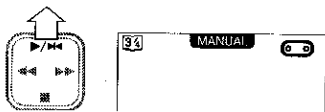

- 2 Select "CAMERA MODE" and then press **▶▶▶** to select "MANUAL".

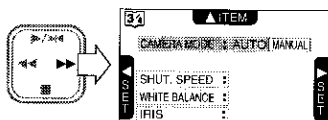

- 3 Press **■** to select "SHUT. SPEED".

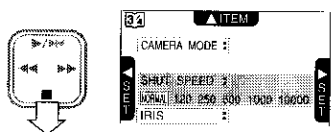

Note:

- Pressing **■** once again will select "WHITE BALANCE", not the "IRIS".

- 4 Press **▶▶** or **◀◀** to select the desired shutter speed.

- You can select from 6 shutter speed settings from 1/50 (NORMAL) to 1/10000.

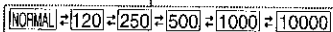
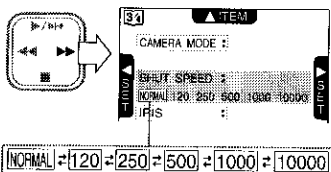

To Return to the Standard Shutter Speed

In step 4, press **◀◀** on the **34** button to select "NORMAL".

To reset the VIEWCAM to Full Auto mode, press **▶▶▶** to select "CAMERA MODE" and then press **◀◀** to select "AUTO" in step 2.

Recommended Shutter Speeds

The faster the shutter speed, the darker the picture becomes. Select the most appropriate shutter speed for the ambient light.

Situation	Recommended shutter speed
<ul style="list-style-type: none"> Recording sports action in bright daylight Recording in bright daylight at a ski resort 	1/10000 sec. 1/1000 sec.
<ul style="list-style-type: none"> Recording outdoor sports on a somewhat cloudy day Recording an outside scene through a car window (when you want to minimize blurs caused by camera shake) 	1/1000 sec. 1/250 sec.
<ul style="list-style-type: none"> When you want to reduce the light by half. Use as a substitute for an ND2 filter. 	1/120 sec.

Note on Recording under Fluorescent Lighting

If the picture on the monitor flickers when recording under fluorescent lighting, you may be able to compensate by changing the shutter speed to 1/120 sec.

Notes:

- Using a fast shutter speed under fluorescent lighting will cause flickering in the picture and possibly periodic colour shifts.
- Recording with a shutter speed higher than 1/50 sec. (standard) tends to darken the picture. Record in bright locations when you use a high shutter speed.

White Balance Lock

MENU button

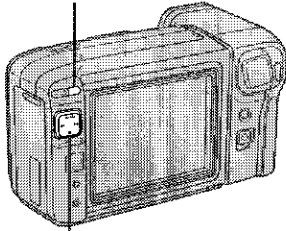

Operation button

- 1 Press the MENU button until **34** appears on the monitor (Camera mode). Press **▶/▶▶** on the Operation button (**⏏**) to select "MANUAL".

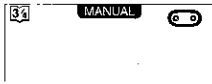
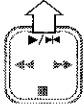

- 2 Select "CAMERA MODE" and then press **▶▶** to select "MANUAL".

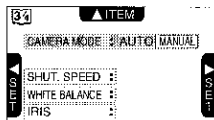
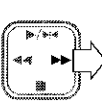

- 3 Press **■** to select "WHITE BALANCE".

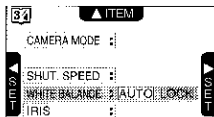
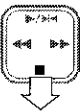

- 4 Aim the VIEWCAM at a solid white subject in the light.

- 5 Press **▶▶** to select "LOCK". The "LOCK" display flashes and the white balance is automatically locked. The "LOCK" display stops flashing when the locking procedure is completed.

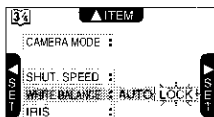
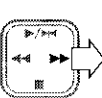

To Return to the Auto Mode

Perform steps 1 to 3, and press **◀◀** on the **⏏** button to select "AUTO".

To reset the VIEWCAM to Full Auto mode, press **▶/▶▶** to select "CAMERA MODE" and then press **◀◀** to select "AUTO" in step 2.

Notes:

- When recording with the white balance locked, if the light source changes or if you move from indoor to outdoor, or vice versa, the white balance may shift. Reset the white balance.
- Even after the white balance has been locked, white balance shifts may occur due to slight changes in illumination or depending on the subject.
- Do not move the VIEWCAM while "LOCK" is flashing in step 5.
- If the "LOCK" indicator does not stop flashing, set the white balance to "AUTO" and reset to "LOCK".

Manual Iris

The VIEWCAM is normally set to Auto Iris mode, which automatically chooses the optimal aperture. When there is too much contrast in brightness between the subject and background, however, you may not be able to record a clear image. Correct iris to adjust the aperture.

MENU button

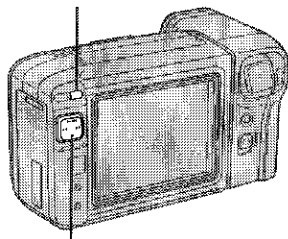

Operation button

- 1 Press the MENU button until **34** appears on the monitor (Camera mode). Press **▶/▶** on the Operation button (**E3**) to select "MANUAL".

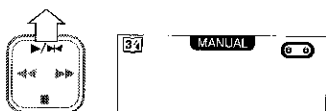

- 2 Select "CAMERA MODE" and then press **▶** to select "MANUAL".

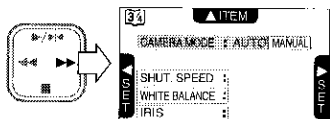

- 3 Press **■** to select "IRIS".

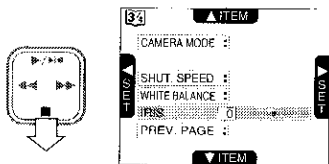

- 4 Press **◀** or **▶** to select the desired value setting.
 - The number shows the selected aperture value. The adjustable range is from -6 (least light) to +6 (most light).

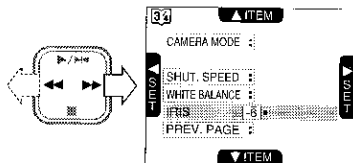

To Return to the Auto Mode

In step 4, press **◀** or **▶** on the **E3** button to select "0".

To reset the VIEWCAM to Full Auto mode, press **▶/▶** to select "CAMERA MODE" and then press **◀** to select "AUTO" in step 2.

Strobe Recording

You can record strobe images (still pictures that capture continuous motion at 1/4 sec. intervals) of subjects with normal sound. You will find it useful when you want to produce a special effect while recording moving subjects such as your friends waving at you.

- 1 While the VIEWCAM is in Recording Standby mode, display the **24** screen (Camera mode) and press **▶/▶** on the Operation button (**E3**) to select "STROBE".

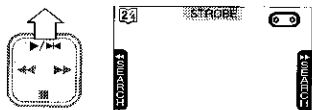

- Each time you press **▶/▶**, the recording mode switches between Normal and Strobe.

- 2 Press the REC START/STOP button to begin strobe recording.
- 3 To return to normal recording, press **▶/▶** on the **E3** button to select "STROBE" again.

Note:

- The picture quality in this mode will be slightly lower than normal pictures.

Recording a Five-second Still Image (Snapshot)

You can record a still picture (snapshot) for about 5 seconds with normal sound simply by pressing the SNAP button.

This is useful when you want to record a scene like a photograph.

- 1 Refer to page 22 to display MENU-PAGE 3 (Camera mode). Press \blacksquare on the Operation button (E) to select "PHOTO SNAP" (1) and then press \blacktriangleleft to select "SNAP" (2). Press the MENU button to turn off the menu.

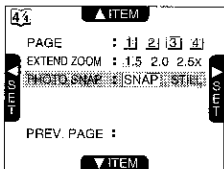
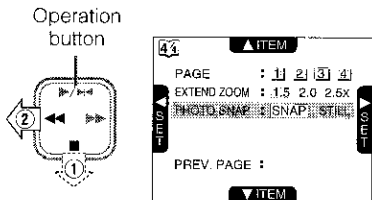

- 2 Press the SNAP button while the VIEWCAM is in Recording Standby mode.

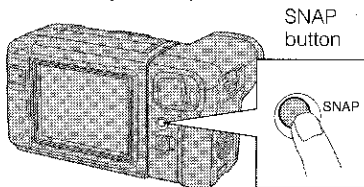

- 3 Press the REC START/STOP button.
 - The CAM indicator is displayed during snapshot recording.

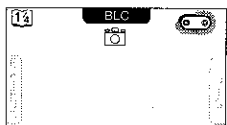

A still image of the subject will be recorded for about 5 seconds, then the VIEWCAM automatically returns to Recording Standby mode.

Notes:

- The image on the monitor will be frozen during snapshot recording.
- If the electronic high-speed shutter is used with the snapshot function, you can record a complete still image without any blurring.
- The picture quality of the snapshot is slightly lower than normal picture quality.

Still Recording

You can record still images of subjects with normal sound.

You will find it useful when you want to record a shot of a tourist information board during sightseeing.

- 1 Refer to page 22 to display MENU-PAGE 3 (Camera mode). Press \blacksquare on the Operation button (E) to select "PHOTO SNAP" (1) and then press \blacktriangleright to select "STILL" (2). Press the MENU button to turn off the menu.

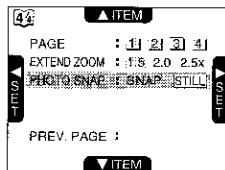
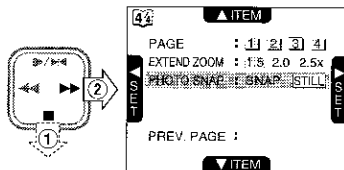

- 2 Press the SNAP button while the VIEWCAM is in Recording Standby mode.
- 3 Press the REC START/STOP button. A still image of the subject will be recorded.

Notes:

- Once the Still Recording mode is set, the VIEWCAM will remain in that mode until it is cancelled, even when switched between Recording mode and Recording Standby mode.
- The picture quality in this mode will be slightly lower than normal pictures.

Caution:

- Do not keep the VIEWCAM in Still Recording mode too long. The monitor may hold an after-image. Turn off the power and wait for a while. The monitor will return to normal.

To Pause Snapshot or Still Recording

Press the REC START/STOP button.

To Return to Normal Recording

Press the SNAP button to disengage the Snap/Still mode.

Lighting

For clear, good-quality recording, 500 to 100,000 lux is needed. Recording is also possible with less light, but the picture quality may suffer. Adequate lighting is also essential for correct white balance.

Brightness (Lux)	Situation (Lux)
100,000	Blue sky Clear day at noon (100,000)
10,000	Clear day at 10 am (65,000) Clear day at 3 pm (35,000) Cloudy day at noon (32,000) Cloudy day at 10 am (25,000)
1,000	Cloudy day, one hour after sunrise (2,000) Clear day, one hour before sunset (1,000) Fluorescent light near window (1,000)
100	Factory floor (700-800) Sales counter in department store (500-700) Bowling alley (500) Library (400-500) Office with fluorescent lighting (400-500) Fluorescent desk lamp (400) Flashlight at 1 m (250) Shop stairway (100)
10	During intermission at movie theatre (15-35) Cigarette lighter at 30 cm (15-20) Candles on birthday cake at 20 cm (10-15) Candlelight

Reference

Lighting is not only one of the most important areas in producing home videos, but also one of the most overlooked. Good lighting can often mean the difference between a great picture and a poor one. Lighting is also essential for correct white balance. In most outdoor, daytime scenes, natural lighting is adequate for home videos. Indoors, the situation becomes more complicated. Artificial lighting is required, and halogen lamps provide the most natural artificial light while maintaining a constant colour temperature over a long operating life. Good lighting is difficult to achieve. There are many problems waiting to catch the unwary. Simply mounting one light or several lights on either side of the VIEWCAM will only make your subject look flat and two-dimensional. To make a subject more interesting, use the lighting to model your subject and to add or create emphasis in a scene.

Colour Temperature (degrees Kelvin)	Situation	Colour	White Balance Range
10,000	Clear day	Blue	A U T O
9,000			
8,000	Cloudy day		
7,000	Rainy day		
6,500	Daylight fluorescent light		
6,000	Camera flashbulb		
5,500			
5,000	Blue photolamp	White	
4,500	White fluorescent light		
3,500	Off-white fluorescent light Tungsten photolamp		
3,200	Halogen lamp		A U T O
2,800	Tungsten lamp Iodine lamp	Yellow	
2,500	Acetylene lamp Kerosene lamp		
2,000	Candlelight	Red	

Notes:

- The figures in the charts are approximations.
- The auto white balance operates automatically within the range of "AUTO" shown in the chart. However, it will satisfactorily operate from 2,500 K up to 8,000 K, although the picture may take on a red or blue tint.

Lighting indicator ("LIGHT")

When the "LIGHT" indicator appears on the monitor, it means that there is not enough illumination for recording. Either move to a brighter location or increase the light. You can also correct the problem by manually setting the gain (see page 31).

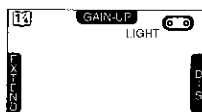

World Clock

This VIEWCAM is equipped with a world clock feature. It allows you to easily adjust the time when you use the VIEWCAM while travelling anywhere in the world outside your home time zone. Set the area, date and time if they are not already set. (See page 25.)

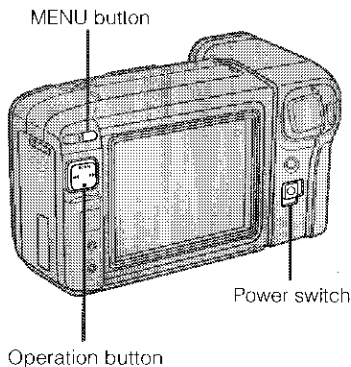

- 4 Press **▶▶** on the **⏮** button to select PAGE **4**.



- 5 Press **■** to select "AREA".

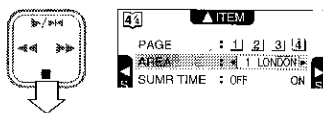

- 6 Press **◀◀** or **▶▶** until "2 PARIS" appears. The VIEWCAM is now set to the Paris time. Press the MENU button to turn off the menu.



Changing the Area of the Time Zone

Example:

Changing the area from London to Paris.

- 1 Hold down the Lock button and slide the Power switch to CAMERA.

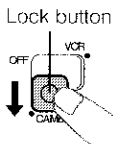

- 2 Press the MENU button until **4** appears on the monitor.

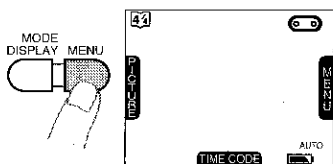

- 3 Press **▶▶** on the Operation button (**⏮**) to select "MENU".



Blank Area Setting

If you do not want to set the area (time zone), you can leave the setting blank. In step 6 above, press **◀◀** or **▶▶** on the **⏮** button until the area setting is blank (after "24").

To turn off the menu display

Press the MENU button.

To Display Area, Date and Time on the Monitor

- 1 Press the MENU button until **4/4** appears, and then press **▶▶** on the Operation button (**⏪**) to select MENU-PAGE **1/1**.
- 2 Press **■** on the **⏪** button to select "DISP".
- 3 Press **◀◀** or **▶▶** to select "DATE" or "DATE+TIME".
- 4 Press the MENU button to turn off the menu display. The area, date and time will be displayed on the monitor.

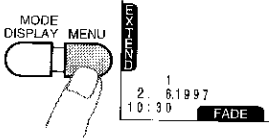

Setting Summer Time (Daylight Saving Time)

- 1 Press the MENU button until **4/4** appears, and then press **▶▶** on the Operation button (**⏪**) to select MENU-PAGE **1/1**.
- 2 Press **■** on the **⏪** button to select "SUMR TIME".
- 3 Press **▶▶** to select "ON". The time automatically changes to summer time.

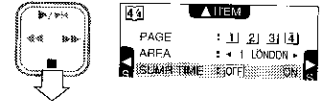

- 4 Press the MENU button to turn off the menu display. The "☀" mark will be displayed to the left of the area indicator. To reset to standard time, set the "SUMR TIME" menu item to "OFF".

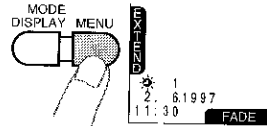

Time Zone Chart

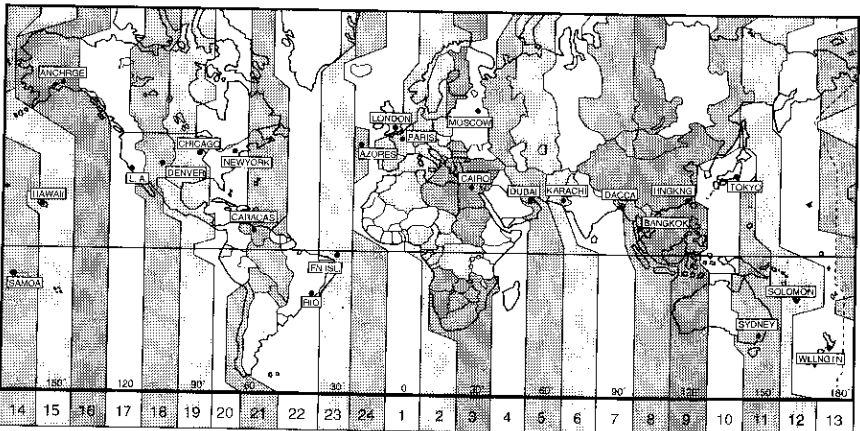

Useful Features for Camera Recording

Useful Features for Camera Recording

Area Table

Area number	Area name	Countries or areas*
1	LONDON	England, Morocco, GMT (Greenwich mean time)
2	PARIS	Austria, France, Germany, Italy, Netherlands, Spain, Sweden, Switzerland, Portugal, CST (Continental Standard Time), Tunisia
3	CAIRO	Egypt, Finland, Greece, Turkey
4	MOSCOW	Ethiopia, Iraq, Kenya, Mauritius, Saudi Arabia, Seychelles, Russia (Moscow)
5	DUBAI	United Arab Emirates
6	KARACHI	Maldives, Pakistan
7	DACCA	Bangladesh, India, Myanmar
8	BANGKOK	Cambodia, Indonesia (Jakarta), Thailand, Vietnam
9	HNGKNG	Australia (Perth), China, Hong Kong, Indonesia (Borneo, Bali), Malaysia, Philippines, Singapore, Taiwan
10	TOKYO	Japan, Korea
11	SYDNEY	Australia (Sydney)
12	SOLOMON	New Caledonia
13	WLLNGTN	Fiji, New Zealand
14	SAMOA	Western Samoa
15	HAWAII	Hawaii Is., Tahiti, HST (Hawaii Standard Time)
16	ANCHRGE	U.S.A. (Alaska), AST (Alaska Standard Time)
17	L.A.	U.S.A. (Los Angeles, San Francisco), PST (Pacific Standard Time)
18	DENVER	U.S.A. (Denver), MST (Mountain Standard Time)
19	CHICAGO	Mexico, U.S.A. (Chicago), CST (Central Standard Time)
20	NEWYORK	Canada (Montreal), Jamaica, Peru, U.S.A. (New York, Washington D.C.), EST (Eastern Standard Time)
21	CARACAS	Chile, Dominica, Venezuela
22	RIO	Argentina, Brazil, Uruguay
23	FN ISL.	Fernando de Noronha
24	AZORES	Azores Islands

* These are common names. The formal may be different.

Picture/Backlight Adjustments 5

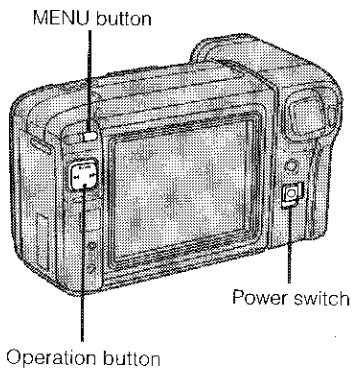

If the picture is difficult to see due to ambient lighting, etc., adjust the monitor picture.

- 1 Set the Power switch to CAMERA.

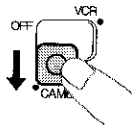

- 2 Press the MENU button until 43 appears on the monitor.

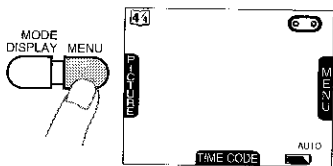

- 3 Press ◀ on the Operation button (E) to select "PICTURE".



- 4 Press ▶ or ◀ on the E button to select the menu item you wish to adjust.

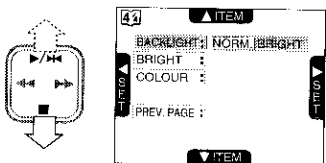

Press ◀ or ▶ to adjust the picture or backlight to your preference.

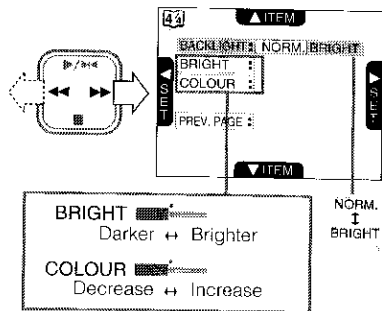

- 6 When you are finished, press the MENU button to turn off the adjustment display.

When the VIEWCAM is in VCR Mode

Press the MENU button until 23 appears on the monitor. Then perform steps 3 through 6 shown above.

Notes:

- In bright daylight, the monitor picture will be easier to see if you set the backlight ("BACKLIGHT") to "BRIGHT".
- The picture adjustments have been factory preset to neutral settings, and the backlight mode ("BACKLIGHT") has been factory preset to normal ("NORM.").
- When the colour is adjusted, the picture on the screen may differ from the picture actually recorded. Do not change the colour settings unless it is necessary.

Recording with the Wide Screen (16:9)

This feature lets you record scenes with the wide-screen feel of a movie shown in a theatre. The top and the bottom of the picture are masked with black bands to produce an effective screen aspect ratio of 16:9.

Setting the Wide Screen Mode

- 1 Press the MENU button until **44** appears on the monitor (Camera mode).

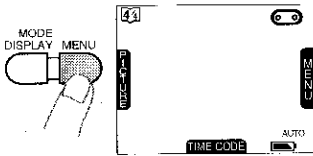

- 2 Press **▶▶** on the Operation button (**▶▶**) to select "MENU".

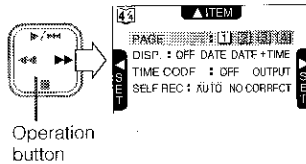

- 3 Press **▶▶** on the **▶▶** button to select MENU-PAGE **2** (**1**) and then press **■** to select "16:9" (**2**).

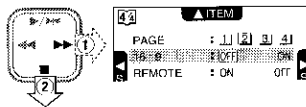

- 4 Press **▶▶** to select "ON". Then, press the MENU button to turn off the menu.

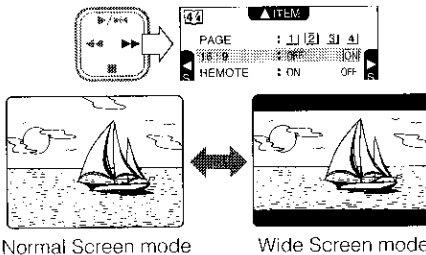

- 5 To return to the normal picture, press **◀◀** to select "OFF" in step 4 above.

Notes:

- When using the fade function (see page 33) in the Wide Screen mode, only the unmasked portion of the screen will fade in or out.
- You can only use the Wide Screen mode when the VIEWCAM is in Camera mode.

Quick Return

When you have been playing back what you have recorded, and wish to quickly return to recording again from the end of the last recorded scene, use the quick return function.

- 1 Set the Power switch to CAMERA.

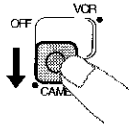

- 2 Press the MENU button until [24] appears on the monitor.

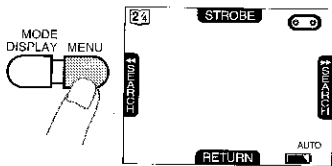

- 3 Press ■ on the Operation button (E) to select "RETURN". The tape will begin winding or rewinding to the end of the last recorded scene.

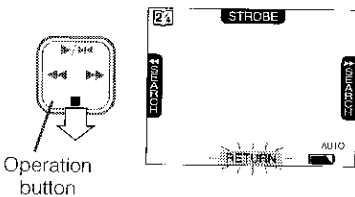

- To cancel, press ■ on the E button to select "RETURN" again.

- 4 When the tape reaches the end of the last recorded scene, the VIEWCAM enters Recording Standby mode.

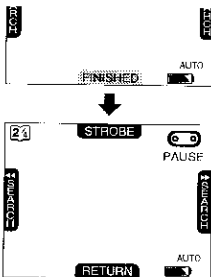

Note:

- If the cassette has been removed since the last recording, or if no recording has been made since the cassette was loaded, "RETURN" indicator will be faintly displayed and the quick return function will not operate.

Edit Search

The edit search feature lets you search, without switching from Camera Recording mode to VCR mode, for the point on the tape where you wish to start recording next.

- 1 In Recording Standby mode, press the MENU button until [24] appears on the monitor.

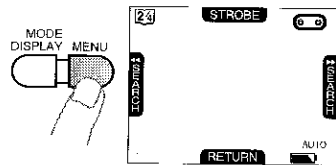

- 2 Hold down ◀◀ for reverse edit search or ▶▶ for forward edit search on the E button.

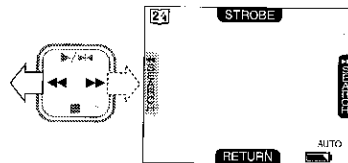

- 3 When you find the point where you want to begin recording, release the button.

Notes:

- Some picture noise appears during reverse edit search.
- Forward edit search is performed at the same speed as normal playback, and reverse edit search is performed at five times the normal playback speed.
- The sound is off during edit search.

Connections and Editing

Using the A/V Pack

The supplied A/V pack lets you connect the VIEWCAM to other audiovisual equipment. Small and lightweight, it comes in handy when travelling or any time you are away from home.

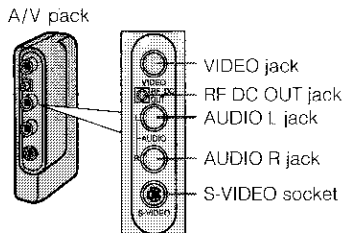

Attaching the A/V Pack

- 1 Remove the A/V pack terminal cover of the VIEWCAM as shown below.

Note:

- Be careful not to lose the cover once it is removed.

- 2 Align the projections on the A/V pack with the openings on the VIEWCAM's mounting panel, insert the A/V pack as shown, then push the A/V pack firmly against the mounting panel until it clicks into place.

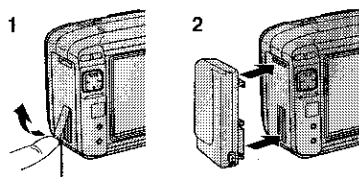

Detaching the A/V Pack

Slide the EJECT release on the A/V pack in the direction of the arrow, and then pull the A/V pack straight out.

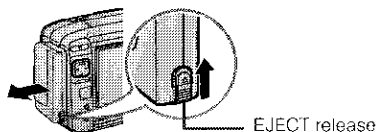

Caution:

- Do not use the A/V pack as a handle; it will cause malfunctions.

Connections for Playback on a TV with Audio/Video Jacks

Although you can enjoy playback on the VIEWCAM's LCD monitor, you can also watch played-back tapes on your TV screen.

- Connect the VIEWCAM to your TV with the supplied audio/video cable, as shown.

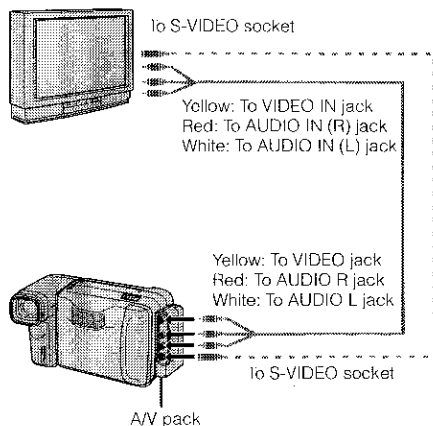

Caution:

- Make sure that the VIEWCAM, TV and other equipment to be connected have been turned off before you make connections. Making connections with any of the components left turned on may cause picture noise or malfunction.

Connection to TV without Audio/Video Jacks

To connect the VIEWCAM to a TV which does not have audio/video jacks, use the supplied A/V pack and the optional VR-H30RF RF converter.

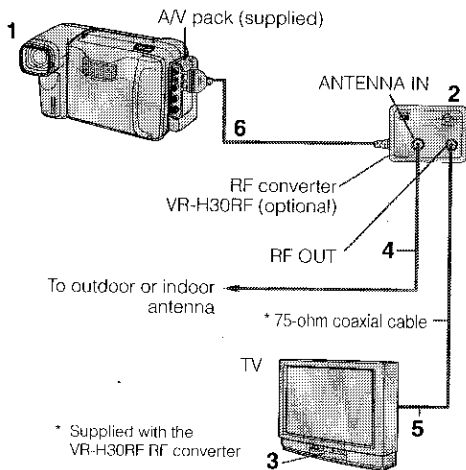

- 1 Attach the A/V pack to the VIEWCAM (see page 59).
- 2 Set the I/G selector on the RF converter according to the TV system in your area ("I" in the U.K.). The channel adjuster on the RF converter is set to CH36. If CH36 is used in your area, set it to a different channel.

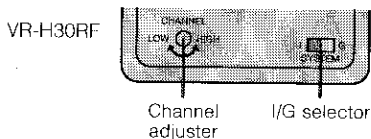

- 3 Set the TV tuner to the same channel as that selected on the RF converter.
- 4 Unplug the antenna cable from the TV and plug it into the ANTENNA IN terminal on the RF converter.
- 5 Plug the 75-ohm coaxial cable into RF OUT terminal on the RF converter and the 75-ohm coaxial antenna terminal on the TV.

- 6 Plug the RF converter cable into the AUDIO, VIDEO, and RF DC OUT jacks on the A/V pack.

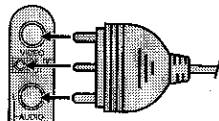

If your TV's antenna input is connected to a VCR

Disconnect the cable between the TV and VCR, and insert the RF converter between them.

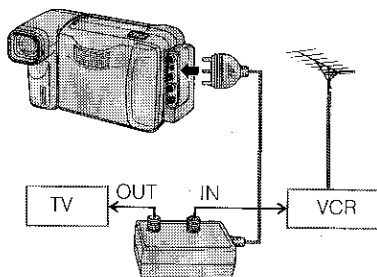

Cautions:

- Use only the VR-H30RF RF converter (optional accessory) with this VIEWCAM.
- The RF converter is a sealed unit. Do not attempt to open or modify it. Do not damage, drop or subject the unit to vibration.
- Unplug the RF converter during lightning storms.

Notes:

- To resume normal TV operation, set the VIEWCAM's Power switch to OFF, or unplug the RF converter cable from the A/V pack if it is still attached to the VIEWCAM.
- The picture may be disturbed during video search or still picture playback. This does not imply a defect in the VIEWCAM.
- I refers to system PAL I and the I/G selector should be in this position for use in U.K., South Africa, and Hong Kong. G refers to system PAL G for use with European PAL systems.
- If UHF channel 36 is an active broadcast channel in your area, any non-broadcast channel from UHF channel 30 to 39 can be selected for viewing the VIEWCAM's output on TV. Adjust the RF converter's output channel adjuster to any of those channels (UHF30-39), and tune your TV to the same channel.

Connection to TV via VCR

- 1 Connect the A/V pack to your VCR with the supplied audio/video cable.
 - If your VCR has a 21-pin Euro-SCART connector, use the RCA/21-pin Euro-SCART conversion connector (QSOCZ0033TAZZ).

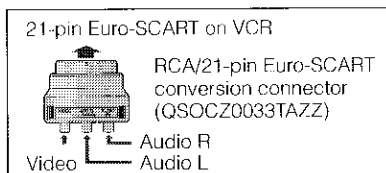

- 2 Set the VCR to its "AV" or "LINE" input channel. Operate the TV as you normally do to see the signal from the VCR. (See the operation manuals for your TV and VCR.)
 - If your VCR has an S-video input socket, connect it to the A/V pack's S-VIDEO socket with the supplied S-video cable.

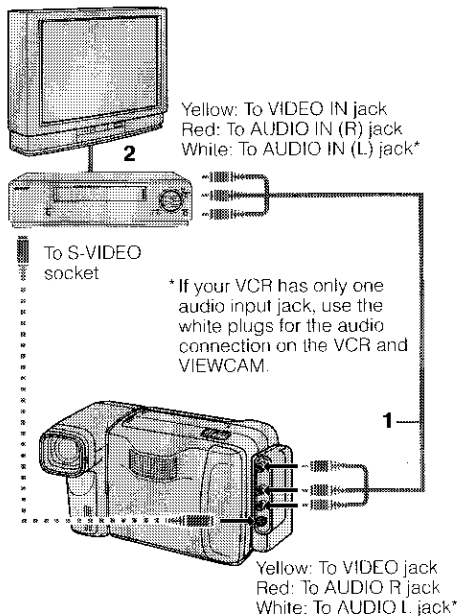

Watching Played-back Tapes on a TV

- 1 Turn on your TV and set it to its "AV" or "VIDEO" channel. (See the operation manual for your TV.)
- 2 Turn on the VIEWCAM in the VCR mode, and begin tape playback as you normally do (see page 35).

Note:

- When the VIEWCAM is connected to a TV for playback, the picture on the TV screen may flicker if the volume on the VIEWCAM is set to maximum. Should this occur, turn the volume down (see page 35).

About the S-video socket

S-video sockets are used to pass the chroma (colour) and luminance (brightness) components of video signals separately. They serve to improve the picture quality in both recording and playback.

Editing

Video editing lets you refine your videos by removing unwanted sequences from your tape, or transposing one sequence with another. This VIEWCAM lets you monitor the source program on the built-in LCD monitor without having to connect it to an external TV or video monitor.

Connect the VIEWCAM to a VCR with the supplied A/V pack and audio/video cable.

- If your VCR has a 21-pin Euro-SCART connector, use the RCA/21-pin Euro-SCART conversion connector (QSOCZ0033TAZZ).

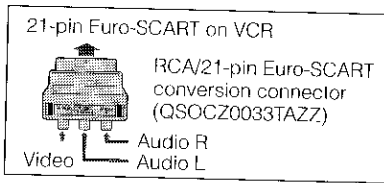

Recording



Yellow: To VIDEO IN jack
Red: To AUDIO IN (R) jack
White: To AUDIO IN (L) jack*

To S-VIDEO socket

*If your VCR has only one audio input jack, use the white plugs for the audio connection on the VCR and VIEWCAM.

Playback

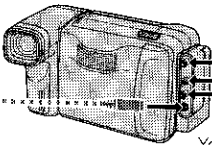

Yellow: To VIDEO jack
Red: To AUDIO R jack
White: To AUDIO L jack*

Note:

- If your VCR has an S-video input socket, connect it to the S-VIDEO socket on the A/V pack with the supplied S-video cable.

Cutting Unwanted Sequences

- 1 Play back the tape to be edited, and locate the beginning and end of the sequence you wish to cut. Write down the time code or the tape counter readings at the beginning and end of that sequence (see pages 39 and 40). Then rewind the tape to the beginning of the portion that you wish to keep.
- 2 Load a blank tape cassette into the recording VCR.
- 3 Set the Power switch to VCR. Press **▶/▶** on the Operation button (**⏮**) to select "PLAY" and press the VCR's REC (Record) button at the same time.
- 4 Press the VCR's Pause/Still button to pause recording when the source tape reaches the beginning of the sequence to be cut.
- 5 Press the VCR's Pause/Still (or Record) button to resume recording when the source tape reaches the end of the sequence to be cut.

To stop editing

Press **■** on the **⏮** button to select "STOP" on the VCR **TC** screen and press the STOP button on the VCR.

Notes:

- Some of the transitions between edited sequences may be slightly off.
- The picture may be disturbed during video search or still picture playback. This does not imply a defect in the VIEWCAM.
- The time code display is convenient when cutting unwanted sequences (see page 39).

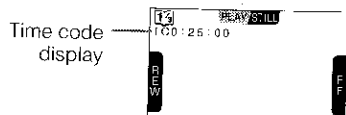

We recommend that you set the "TIME CODE" menu item to "OFF". If you set it to "OUTPUT", the time code will be recorded along with the edited sequences.

Fluorescent Lamp Backlight

The fluorescent lamp backlight used in this VIEWCAM will eventually need replacing. If you continue to use the VIEWCAM when the fluorescent lamp has almost reached the end of its service life, the "REPLACE THE LAMP." indicator will be displayed on the monitor for approximately one minute. When this occurs, purchase a replacement lamp (KLMPV0018TAZZ) from your dealer or a SHARP Full Line Parts Distributor, and replace the old lamp.

REPLACE THE LAMP.

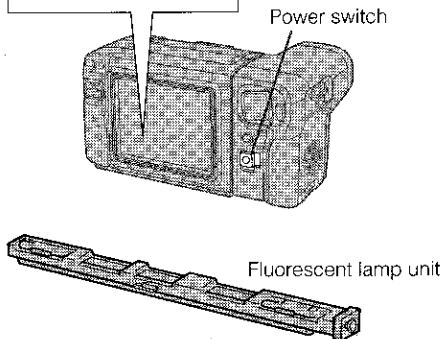

Replacing the Fluorescent Lamp Backlight

- 1 Set the Power switch to OFF to turn off the VIEWCAM, and wait about 15 minutes for the lamp unit to cool down.

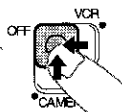

- 2 Rotate the camera module of the VIEWCAM halfway forward as shown.

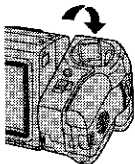

- 3 Remove the lamp compartment cover: insert a pointed object such as the point of a pen into the opening above the cover, push the cover release "L" down, and then pull off the cover.

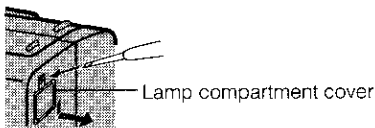

- 4 Carefully hold the end (white knob) of the lamp unit with tweezers, and pull it out.

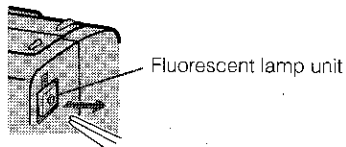

- 5 Insert the replacement lamp unit into the compartment. See note below.

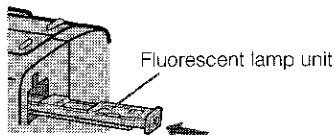

- 6 Replace the fluorescent lamp compartment cover.

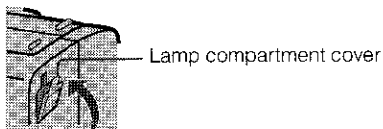

Notes:

- In step 5 above, be sure to insert the replacement fluorescent lamp straight in, in the direction of the arrow, into the compartment. Do not press diagonally as it may cause contact failure.
- The fluorescent light may flicker when first turned on. Should this occur, turn off the VIEWCAM, and then turn it on again.
- When used in cold locations, the fluorescent lamp may lose some of its brightness.
- Remove the battery pack before replacing the fluorescent lamp.

Caution:

- The fluorescent lamp is hot during and immediately after use of the VIEWCAM. Wait at least 15 minutes after turning the power off before attempting to change the lamp, to allow time for it to cool down. Attempting to change the lamp unit while it is still hot may result in burns or other injuries.

Before Requesting Service

The following conditions do not always denote trouble. Therefore, perform the checks described below before calling for service. If the problem cannot be corrected by the use of this guide, remove the mains plugs from the wall socket, and contact the dealer or supplier from whom the unit was purchased in order to obtain service. Where this is not possible please contact the telephone number listed below. You will then be given details of how to obtain service.

0345-125387

Please note: All calls will be charged at local rate.

Certain replacement parts and accessories may be obtained from our main parts distributor, who can be contacted on the following numbers:

WILLOW VALE ELECTRONICS LTD.

MANCHESTER 0161-682-1415 READING 01734-876444

In the unlikely event of this equipment requiring repair during the guarantee period, you will need to provide proof of the date of purchase to the repairing company. Please keep your invoice or receipt, which is supplied at the time of purchase.

	Symptom	Possible cause	Suggested solution
Power	No power.	• Power source is not properly connected.	• Connect power source properly. (pp. 15-17)
		• Battery pack is not charged.	• Charge battery pack sufficiently. (p. 14)
		• Dew in VIEWCAM.	• Wait until dew dries. (p. 6)
		• Safety function is in effect.	• Set Power switch to OFF and remove battery pack; wait for two seconds, then re-install battery pack and turn on power. (p. 15)
Recording	REC START/STOP button does not work.	• Erasure protect tab on video cassette is open.	• Close tab or use a new cassette. (p. 9)
	Power suddenly turns off.	• VIEWCAM left in Recording Standby mode for five minutes.	• Set Power switch to OFF and then back to CAMERA.
	Monitor picture is hard to see.	• Inappropriate picture adjustments.	• Adjust picture. (p. 56)
	Auto focus does not work.	• Manual Focus mode is engaged.	• Set to Auto Focus mode. (p. 47)
		• Zoom used on close subject.	• Zoom out on subject. (p. 29)
		• Subject has little contrast in brightness, or is full of horizontal or vertical stripes.	• Focus manually. (p. 47)
	Bright subject produces wide vertical lines.	• Occurs when shooting subject with strong contrast to the background. Does not indicate a malfunction.	—
No audio from speaker when recording.	• Speaker does not work during Camera mode. (Volume control in Camera mode only affects earphone volume.)	—	
Automatically zooms out without operating Zoom buttons.	• VIEWCAM is unable to focus when zooming in on subject within 1.5 m, and automatically zooms out until it focuses on subject.	• Zoom out. (p. 29)	
	• No subject in the field of view.	• Direct lens to some subject, or set zoom to widest angle before shooting. (p. 29)	
Playback	Tape stops midway through rewind or fast forward.	• Counter is in memory mode.	• Disengage memory mode. (p. 40)
	No image appears on connected TV screen.	• Video input channel on TV or TV channel is not selected properly.	• Select video input channel on TV or TV channel properly. (pp. 59-61)
		• A/V cable is not properly connected.	• Connect A/V cable properly. (pp. 59, 61)
	• A/V pack is not properly connected.	• Connect A/V pack properly. (p. 59)	

Before Requesting Service

	Symptom	Possible cause	Suggested solution
Playback	Cannot play back, rewind or fast forward tape.	• Tape already wound or rewound completely.	• Rewind or fast forward tape to desired point. (p. 35)
	During playback, mosaic patterns appear or picture disappears.	• Dirty video heads.	• Call for service.
		• Old or worn tape.	• Use a new video cassette.
Recording & Playback	No power in VCR or Camera mode.	• Depleted battery pack.	• Use fully charged battery pack. (p. 14)
		• AC adaptor cord removed from power outlet.	• Plug AC adaptor cord into power outlet. (p. 16)
	Cassette will not eject.	• Power source is not properly connected.	• Connect power source properly. (pp. 15-17)
		• Battery pack is not charged.	• Charge battery pack sufficiently. (p. 14)
		• VIEWCAM is recording.	• Stop tape and try again.
	No buttons operate.	• Dew in VIEWCAM.	• Wait until dew dries. (p. 6)
No image on monitor.	• Backlight has been turned off.	• Press MODE DISPLAY button, or set Power switch to OFF and then back to CAMERA or VCR. (p. 37)	
	• Fluorescent lamp is burned out.	• Replace with new fluorescent lamp unit. (p. 63)	
Cannot edit to connected VCR.	• A/V or S-video cable is not properly connected.	• Connect A/V or S-video cable properly. (p. 59)	
	• A/V pack is not properly connected.	• Connect A/V pack properly. (p. 59)	
Lens makes rattling sound when VIEWCAM is moved in VCR mode or with power off.	• Does not indicate a malfunction.	—	
Remote control does not function.	• "REMOTE" menu item is set to "OFF".	• Set "REMOTE" menu item to "ON". (p. 43)	
	• Remote control lithium battery has run down.	• Replace remote control lithium battery with a new one. (p. 13)	
	• Remote control used beyond operating range.	• Use remote control within operating range. (p. 43)	
	• Intense daylight falling on VIEWCAM's photoreceptor.	• Protect photoreceptor from exposure to intense daylight. (p. 43)	
	• Obstacle between remote control and VIEWCAM's photoreceptor.	• Remove obstacle or use remote control from different angle. (p. 43)	

Notes:

- This unit is equipped with a microprocessor. Its performance could be adversely affected by external electrical noise or interference. If this should happen, turn off the power and disconnect the unit from any power sources, including lithium batteries, etc. Then reconnect the power sources (to resume operation).
- If the characters displayed on the monitor screen appear to malfunction, disconnect the power source and remove the lithium battery, then reconnect the power source, insert the lithium battery, and turn the power on again. The characters on the monitor should be normal. Set the date and time, then resume operation.

Specifications

- Signal System: PAL standard
- Recording System: 2 rotary heads, helical scanning system
- Cassette: Digital VCR Mini DV video cassette
- Recording/Playback Time: 60 minutes (DVM60)
- Tape Speed: 18.831 mm/second
- Pickup Device: $\frac{1}{4}$ " (6.4 mm, effective size: 4.5 mm) CCD image sensor (with approx. 470,000 pixels including optical black)
- Lens: 12 \times power zoom lens (F1.8, f=4.2 50.4 mm), full-range auto focus
- Lens Filter Diameter: 37 mm
- Monitor: 4" (10.1 cm)— full-colour LCD screen (TFT active matrix)
- Microphone: Electret stereo microphone
- Colour Temperature Compensation: Auto white balance with white balance lock
- Minimum Illumination: 6 lux* (with gain-up, and digital zoom off)
- Video Output Level: 1.0 Vp-p 75-ohm unbalanced
- Audio Output Level: 8 dBs, impedance less than 2.2 kohms
- Speaker Output: 300 mW
- External Microphone Input: 3.5 mm diameter mini-plug, -66 dBs, output impedance 6.8 kohms, DC 4 V, for plug-in-power microphone use
- Power Requirement: DC 3.6 V
- Power Consumption: 8.5 W (during camera recording in full auto mode with zoom motor off, backlight in normal mode)
- Operating Temperature: 0°C to +40°C
- Operating Humidity: 30% to 80%
- Storage Temperature: -20°C to +60°C
- Dimensions (approx.): 181 mm (W) \times 99 mm (H) \times 88 mm (D)
- Weight (approx.): 690 g (without battery pack, lithium battery, video cassette)

AC Adaptor/Battery Charger (UADP-0215TAZZ)

- Power Requirement: AC 110–240 V, 50/60 Hz
- DC Output: 4.5 V
- Power Consumption: 25 W
- Dimensions (approx.): 120 mm (W) \times 51 mm (H) \times 101.5 mm (D)
- Weight (approx.): 460 g

Specifications are subject to change without notice.

*Minimum illumination: Since there is no widely accepted testing procedure for determining minimum illumination capability, lux ratings are comparable only between models from the same manufacturer.

Notes

SHARP CORPORATION

Osaka, Japan

SHARP ELECTRONICS (U.K.) LTD.

Sharp House, Thorp Road, Newton Heath
Manchester M40 5BE