

# SHARP SERVICE MANUAL

No. S99C6LC60E77U



## LCD COLOR TELEVISION

### LC-60E77UN

### LC-65E77UM

### LC-C6077UN

### MODELS LC-C6577UM

In the interests of user-safety (Required by safety regulations in some countries) the set should be restored to its original condition and only parts identical to those specified should be used.

## CONTENTS

### SAFETY PRECAUTION

IMPORTANT SERVICE SAFETY PRECAUTION.....i	
PRECAUTIONS A PRENDRE LORS DE LA REPARATION.....ii	
PRECAUTIONS FOR USING LEAD-FREE SOLDER ..... iii	

### CHAPTER 1. SPECIFICATIONS

[1] SPECIFICATIONS .....	1-1
--------------------------	-----

### CHAPTER 2. OPERATION MANUAL

[1] Parts Name .....	2-1
----------------------	-----

### CHAPTER 3. DIMENSIONS

[1] DIMENSIONS (LC-60E77UN/LC-C6077UN).....	3-1
[2] DIMENSIONS (LC-65E77UM/LC-C6577UM).....	3-2

### CHAPTER 4. REMOVING OF MAJOR PARTS

[1] REMOVING OF MAJOR PARTS (LC-60E77UN/LC-C6077UN).....	4-1
[2] REMOVING OF MAJOR PARTS (LC-65E77UM/LC-C6577UM).....	4-7

### CHAPTER 5. ADJUSTMENT

[1] ADJUSTMENT PROCEDURE .....	5-1
--------------------------------	-----

[2] PUBLIC MODE SETTING PROCEDURE.....	5-18
--	------

### CHAPTER 6. TROUBLESHOOTING TABLE

[1] TROUBLESHOOTING TABLE .....	6-1
---------------------------------	-----

### CHAPTER 7. MAJOR IC INFORMATIONS

[1] MAJOR IC INFORMATIONS .....	7-1
---------------------------------	-----

### CHAPTER 8. OVERALL WIRING/SYSTEM BLOCK DIAGRAM

[1] OVERALL WIRING DIAGRAM (LC-60E77UN/LC-C6077UN) .....	8-1
[2] OVERALL WIRING DIAGRAM (LC-65E77UM/LC-C6577UM) .....	8-2
[3] SYSTEM BLOCK DIAGRAM.....	8-3

### CHAPTER 9. PRINTED WIRING BOARD ASSEMBLIES

[1] KEY Unit, R/C, LED Unit Unit .....	9-1
[2] MAIN Unit .....	9-2

### CHAPTER 10. SCHEMATIC DIAGRAM

[1] DESCRIPTION OF SCHEMATIC DIAGRAM.....	10-1
[2] SCHEMATIC DIAGRAM.....	10-2

### Parts Guide

Parts marked with "⚠" are important for maintaining the safety of the set. Be sure to replace these parts with specified ones for maintaining the safety and performance of the set.

## SAFETY PRECAUTION

### IMPORTANT SERVICE SAFETY PRECAUTION

- Service work should be performed only by qualified service technicians who are thoroughly familiar with all safety checks and the servicing guidelines which follow:

#### ■WARNING

1. For continued safety, no modification of any circuit should be attempted.
2. Disconnect AC power before servicing.

**CAUTION: FOR CONTINUED PROTECTION AGAINST A RISK OF FIRE REPLACE ONLY WITH SAME TYPE FUSE.**

- F101 (125V 6.3A) (LC-60E77UN/LC-C6077UN)
- F102 (125V 6.3A) (LC-60E77UN/LC-C6077UN)
- F301 (125V 6.3A) (LC-60E77UN/LC-C6077UN)
- F302 (125V 6.3A) (LC-60E77UN/LC-C6077UN)
- F7000 (250V 12A) (LC-60E77UN/LC-C6077UN)
- F101 (250V 4A) (LC-65E77UM/LC-C6577UM)
- F102 (250V 1A) (LC-65E77UM/LC-C6577UM)
- F103 (250V 4A) (LC-65E77UM/LC-C6577UM)
- F401 (250V 4A) (LC-65E77UM/LC-C6577UM)
- F402 (250V 1A) (LC-65E77UM/LC-C6577UM)
- F403 (250V 4A) (LC-65E77UM/LC-C6577UM)
- F7000 (250V 12A) (LC-65E77UM/LC-C6577UM)

#### ■BEFORE RETURNING THE RECEIVER (Fire & Shock Hazard)

Before returning the receiver to the user, perform the following safety checks:

3. Inspect all lead dress to make certain that leads are not pinched, and check that hardware is not lodged between the chassis and other metal parts in the receiver.
4. Inspect all protective devices such as non-metallic control knobs, insulation materials, cabinet backs, adjustment and compartment covers or shields, isolation resistor-capacitor networks, mechanical insulators, etc.
5. To be sure that no shock hazard exists, check for leakage current in the following manner.

#### SAFETY NOTICE

Many electrical and mechanical parts in LCD color television have special safety-related characteristics.

These characteristics are often not evident from visual inspection, nor can protection afforded by them be necessarily increased by using replacement components rated for higher voltage, wattage, etc.

Replacement parts which have these special safety characteristics are identified in this manual; electrical components having such features are identified by "⚠" and shaded areas in the Replacement Parts List and Schematic Diagrams.

- Plug the AC cord directly into a 120 volt AC outlet.
- Using two clip leads, connect a 1.5k ohm, 10 watt resistor paralleled by a 0.15µF capacitor in series with all exposed metal cabinet parts and a known earth ground, such as electrical conduit or electrical ground connected to an earth ground.
- Use an AC voltmeter having with 5000 ohm per volt, or higher, sensitivity or measure the AC voltage drop across the resistor.
- Connect the resistor connection to all exposed metal parts having a return to the chassis (antenna, metal cabinet, screw heads, knobs and control shafts, escutcheon, etc.) and measure the AC voltage drop across the resistor.

All checks must be repeated with the AC cord plug connection reversed. (If necessary, a nonpolarized adaptor plug must be used only for the purpose of completing these checks.)

Any reading of 0.75 Vrms (this corresponds to 0.5 mA rms AC.) or more is excessive and indicates a potential shock hazard which must be corrected before returning the monitor to the owner.

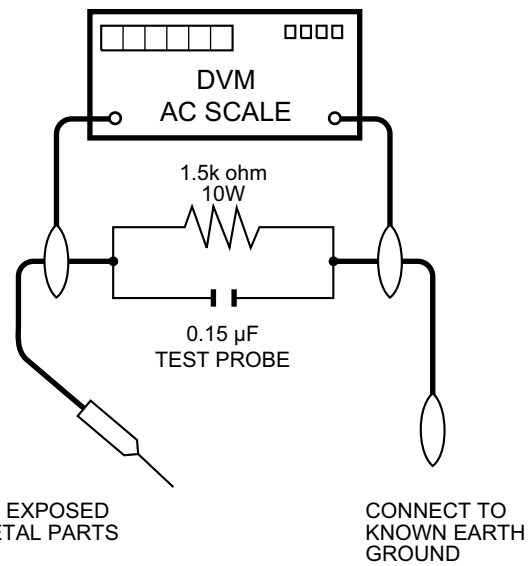

For continued protection, replacement parts must be identical to those used in the original circuit.

The use of a substitute replacement parts which do not have the same safety characteristics as the factory recommended replacement parts shown in this service manual, may create shock, fire or other hazards.

## PRECAUTIONS A PRENDRE LORS DE LA REPARATION

- Ne peut effectuer la réparation qu'un technicien spécialisé qui s'est parfaitement accoutumé à toute vérification de sécurité et aux conseils suivants.

### ■ AVERTISSEMENT

1. N'entreprendre aucune modification de tout circuit. C'est dangereux.
2. Débrancher le récepteur avant toute réparation.

**CAUTION: FOR CONTINUED PROTECTION AGAINST A RISK OF FIRE REPLACE ONLY WITH SAME TYPE FUSE.**

F101 (125V 6.3A) (LC-60E77UN/LC-C6077UN)  
 F102 (125V 6.3A) (LC-60E77UN/LC-C6077UN)  
 F301 (125V 6.3A) (LC-60E77UN/LC-C6077UN)  
 F302 (125V 6.3A) (LC-60E77UN/LC-C6077UN)  
 F7000 (250V 12A) (LC-60E77UN/LC-C6077UN)  
 F101 (250V 4A) (LC-65E77UM/LC-C6577UM)  
 F102 (250V 1A) (LC-65E77UM/LC-C6577UM)  
 F103 (250V 4A) (LC-65E77UM/LC-C6577UM)  
 F401 (250V 4A) (LC-65E77UM/LC-C6577UM)  
 F402 (250V 1A) (LC-65E77UM/LC-C6577UM)  
 F403 (250V 4A) (LC-65E77UM/LC-C6577UM)  
 F7000 (250V 12A) (LC-65E77UM/LC-C6577UM)

- Brancher le cordon d'alimentation directement à une prise de courant de 120V. (Ne pas utiliser de transformateur d'isolation pour cet essai).
- A l'aide de deux fils à pinces, brancher une résistance de 1.5 k $\Omega$  10 watts en parallèle avec un condensateur de 0.15 $\mu$ F en série avec toutes les pièces métalliques exposées du coffret et une terre connue comme une conduite électrique ou une prise de terre branchée à la terre.
- Utiliser un voltmètre CA d'une sensibilité d'au moins 5000 $\Omega$ /V pour mesurer la chute de tension en travers de la résistance.
- Toucher avec la sonde d'essai les pièces métalliques exposées qui présentent une voie de retour au châssis (antenne, coffret métallique, tête des vis, arbres de commande et des boutons, écusson, etc.) et mesurer la chute de tension CA en-travers de la résistance. Toutes les vérifications doivent être refaites après avoir inversé la fiche du cordon d'alimentation. (Si nécessaire, une prise d'adaptation non polarisée peut être utilisée dans le but de terminer ces vérifications.)  
 La tension de pointe mesurée ne doit pas dépasser 0.75V (correspondante au courant CA de pointe de 0.5mA). Dans le cas contraire, il y a une possibilité de choc électrique qui doit être supprimée avant de rendre le récepteur au client.

### ■ VERIFICATIONS CONTRE L'INCEN-DIE ET LE CHOC ELECTRIQUE

Avant de rendre le récepteur à l'utilisateur, effectuer les vérifications suivantes.

3. Inspecter tous les faisceaux de câbles pour s'assurer que les fils ne soient pas pincés ou qu'un outil ne soit pas placé entre le châssis et les autres pièces métalliques du récepteur.
4. Inspecter tous les dispositifs de protection comme les boutons de commande non-métalliques, les isolants, le dos du coffret, les couvercles ou blindages de réglage et de compartiment, les réseaux de résistancecapacité, les isolateurs mécaniques, etc.
5. S'assurer qu'il n'y ait pas de danger d'électrocution en vérifiant la fuite de courant, de la façon suivante:

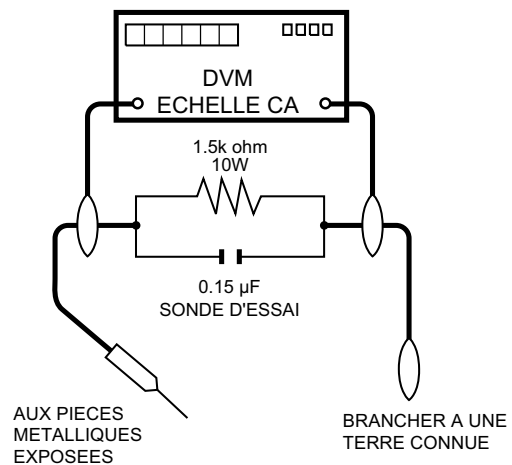

### AVIS POUR LA SECURITE

De nombreuses pièces, électriques et mécaniques, dans les téléviseur ACL présentent des caractéristiques spéciales relatives à la sécurité, qui ne sont souvent pas évidentes à vue. Le degré de protection ne peut pas être nécessairement augmentée en utilisant des pièces de remplacement étalonnées pour haute tension, puissance, etc.

Les pièces de remplacement qui présentent ces caractéristiques sont identifiées dans ce manuel; les pièces électriques qui présentent ces particularités sont identifiées par la marque " $\triangle$ " et hachurées dans la liste des pièces de remplacement et les diagrammes schématiques.

Pour assurer la protection, ces pièces doivent être identiques à celles utilisées dans le circuit d'origine. L'utilisation de pièces qui n'ont pas les mêmes caractéristiques que les pièces recommandées par l'usine, indiquées dans ce manuel, peut provoquer des électrocutions, incendies, radiations X ou autres accidents.

**PRECAUTIONS FOR USING LEAD-FREE SOLDER**

**■Employing lead-free solder**

- “PWBs” of this model employs lead-free solder. The LF symbol indicates lead-free solder, and is attached on the PWBs and service manuals. The alphabetical character following LF shows the type of lead-free solder.

Example:



Indicates lead-free solder of tin, silver and copper.

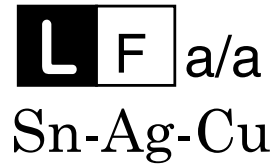

Indicates lead-free solder of tin, silver and copper.

**■Using lead-free wire solder**

- When fixing the PWB soldered with the lead-free solder, apply lead-free wire solder. Repairing with conventional lead wire solder may cause damage or accident due to cracks.

As the melting point of lead-free solder (Sn-Ag-Cu) is higher than the lead wire solder by 40 °C, we recommend you to use a dedicated soldering bit, if you are not familiar with how to obtain lead-free wire solder or soldering bit, contact our service station or service branch in your area.

**■Soldering**

- As the melting point of lead-free solder (Sn-Ag-Cu) is about 220 °C which is higher than the conventional lead solder by 40 °C, and as it has poor solder wettability, you may be apt to keep the soldering bit in contact with the PWB for extended period of time. However, Since the land may be peeled off or the maximum heat-resistance temperature of parts may be exceeded, remove the bit from the PWB as soon as you confirm the steady soldering condition.

Lead-free solder contains more tin, and the end of the soldering bit may be easily corroded. Make sure to turn on and off the power of the bit as required.

If a different type of solder stays on the tip of the soldering bit, it is alloyed with lead-free solder. Clean the bit after every use of it.

When the tip of the soldering bit is blackened during use, file it with steel wool or fine sandpaper.

- Be careful when replacing parts with polarity indication on the PWB silk.

Lead-free wire solder for servicing

PARTS CODE	PRICE RANK	PART DELIVERY	DESCRIPTION
ZHNDai123250E	BL	J	φ0.3mm 250g (1roll)
ZHNDai126500E	BK	J	φ0.6mm 500g (1roll)
ZHNDai12801KE	BM	J	φ1.0mm 1kg (1roll)

# CHAPTER 1. SPECIFICATIONS

## [1] SPECIFICATIONS

Item		Model: LC-60E77UN/LC-C6077UN	Model: LC-65E77UM/LC-C6577UM	
LCD panel	Size	60" Class (60 <sup>1</sup> / <sub>32</sub> " Diagonal)	65" Class (64 <sup>33</sup> / <sub>64</sub> " Diagonal)	
	Resolution	2,073,600 pixels (1,920x 1,080)		
TV Function	TV-standard (CCIR)	American TV Standard ATSC/NTSC System		
	Receiving Channel	VHF/UHF	VHF 2-13ch, UHF 14-69ch	
		CATV	1-135ch (non-scrambled channel only)	
		Digital Terrestrial Broadcast (8VSB)	2-69ch	
		Digital cable <sup>*1</sup> (64/256 QAM)	1-135ch (non-scrambled channel only)	
Audio multiplex	BTSC System			
Audio out		10W x 2		
Terminals	Rear	INPUT 1	AV in, COMPONENT in	
		INPUT 2	COMPONENT in, S-VIDEO in	
		INPUT 4	ANALOG RGB (PC) in (15-pin mini D-sub female connector), Audio in (Ø 3.5 mm jack)	
		INPUT 6	HDMI in with HDCP, Audio in (Ø 3.5 mm jack)	
		INPUT 7	HDMI in with HDCP	
		INPUT 8	HDMI in with HDCP	
		ANT/CABLE	75 Ω Unbalance, F Type x 1 for Analog (VHF/UHF/CATV) and Digital (AIR/CABLE)	
		AUDIO	Audio in (Ø 3.5 mm jack)	
		DIGITAL AUDIO OUTPUT	Optical Digital audio output x 1 (PCM/Dolby Digital)	
		OUTPUT	Audio out	
	RS-232C	9-pin D-sub male connector		
	Side	INPUT 3	AV in	
		INPUT 5	HDMI in with HDCP	
SERVICE		Software update		
OSD language		English/French/Spanish		
Power Requirement		AC 120 V, 60 Hz		
Power Consumption		390 W (0.4 W Standby with AC 120 V)	525 W (0.4 W Standby with AC 120 V)	
Weight	TV + stand	92.6 lbs./42.0 kg	110.2 lbs./50.0 kg	
	TV only	81.6 lbs./37.0 kg	99.2 lbs./45.0 kg	
Dimension <sup>*2</sup> (W x H x D)	TV + stand	56 <sup>5</sup> / <sub>8</sub> x 37 <sup>29</sup> / <sub>64</sub> x 17 <sup>9</sup> / <sub>16</sub> inch	60 <sup>3</sup> / <sub>4</sub> x 39 <sup>27</sup> / <sub>32</sub> x 17 <sup>9</sup> / <sub>16</sub> inch	
	TV only	56 <sup>5</sup> / <sub>8</sub> x 35 <sup>11</sup> / <sub>64</sub> x 4 <sup>45</sup> / <sub>64</sub> inch	60 <sup>3</sup> / <sub>4</sub> x 37 <sup>39</sup> / <sub>64</sub> x 4 <sup>45</sup> / <sub>64</sub> inch	
Operating temperature		+ 32°F to +104°F (0°C to +40°C)		

<sup>\*1</sup> Emergency alert messages via Cable are unreceivable.

<sup>\*2</sup> The dimensional drawings are shown on the inside back cover.

- As part of policy of continuous improvement, SHARP reserves the right to make design and specification changes for product improvement without prior notice. The performance specification figures indicated are nominal values of production units. There may be some deviations from these values in individual units.

### Optional Accessory

The listed optional accessory is available for the Liquid Crystal Television. Please purchase it at your nearest shop.

- Additional optional accessories may be available in the near future. When purchasing, please read the newest catalogue for compatibility and check the availability.

Part name	Model number
Wall mount bracket	AN-52AG4 (for LC-60E77UN/LC-C6077UN)
	AN-65AG1 (for LC-65E77UM/LC-C6577UM)

## CHAPTER 2. OPERATION MANUAL

### [1] Parts Name

#### TV (Front)

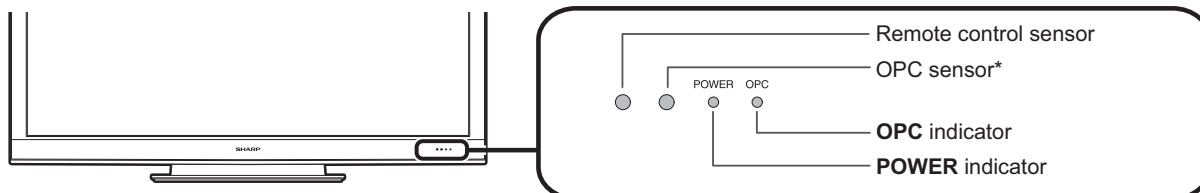

\* OPC: Optical Picture Control

#### TV (Rear/Side)

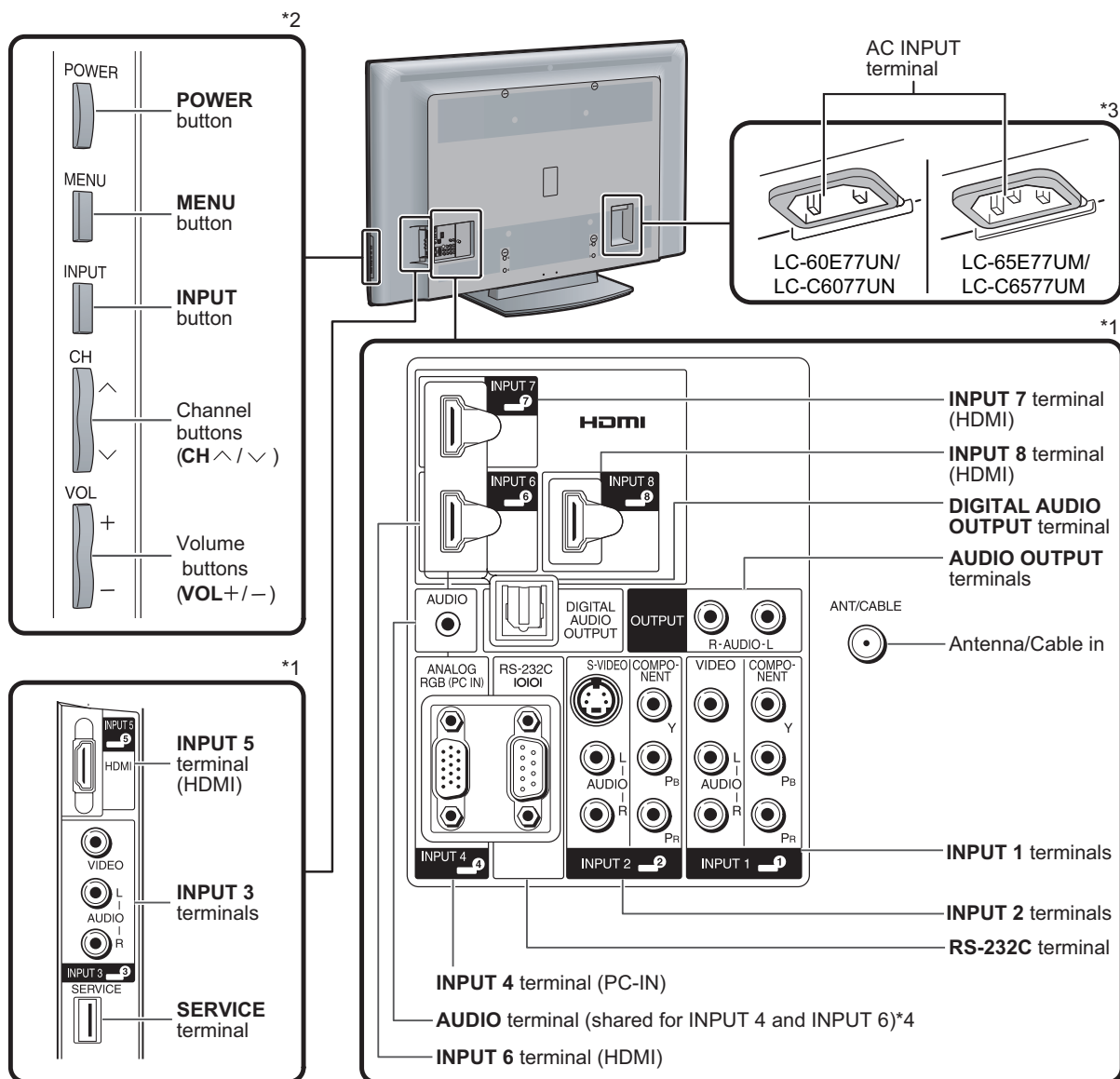

\*1 External equipment connection.

\*2 Button operations.

\*3 Connecting the AC cord.

\*4 Details on the PC Audio Select function.

#### NOTE

- The illustrations in this operation manual are for explanation purposes and may vary slightly from the actual operations.
- The examples used throughout this manual are based on the LC-65E77UM model.

1. Remote Control Unit (LC-60E77UN/LC-65E77UM)

Remote Control Unit

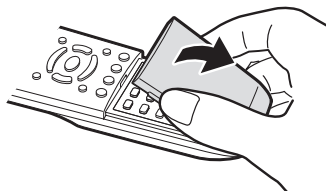
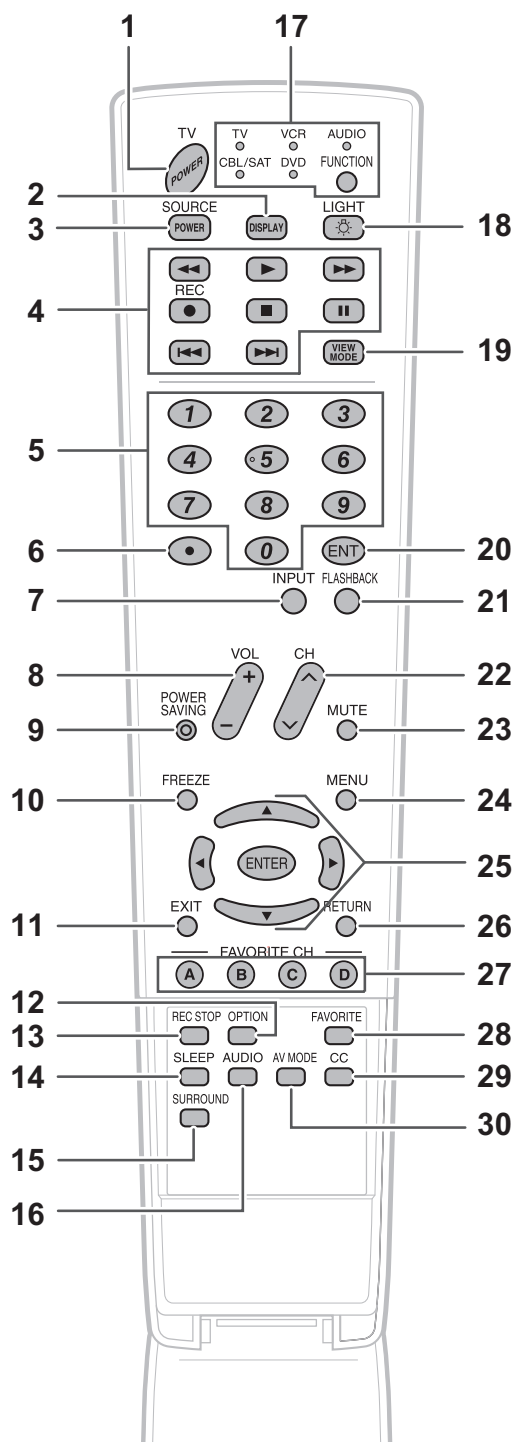

NOTE

• When using the remote control unit, point it at the TV.

- 1 **TV POWER:** Switch the TV power on or enter standby.
- 2 **DISPLAY:** Display the channel information.
- 3 **SOURCE POWER:** Turns the power of the external equipment on and off.
- 4 **External equipment operational buttons:** Operate the external equipment.
- 5 **0-9:** Set the channel.
- 6 **• (DOT):**
- 7 **INPUT:** Select a TV input source. (TV, INPUT 1, INPUT 2, INPUT 3, INPUT 4, INPUT 5, INPUT 6, INPUT 7, INPUT 8)
- 8 **VOL +/- :** Set the volume.
- 9 **POWER SAVING:** Select Power Saving settings.
- 10 **FREEZE:** Set the still image. Press again to return to normal screen.
- 11 **EXIT:** Turn off the menu screen.
- 12 **OPTION:** Display the AQUOS LINK MENU screen. This button will function only when AQUOS LINK is used.
- 13 **REC STOP:** Stops one touch recording. This button will function only when AQUOS LINK is used.
- 14 **SLEEP:** Set the sleep timer.
- 15 **SURROUND:** Select Surround settings.
- 16 **AUDIO:** Selects the MTS/SAP or the audio mode during multi-channel audio broadcasts.
- 17 **FUNCTION:** Switches the remote control for TV, CBL/SAT, VCR, DVD and AUDIO operation. Indicator lights up for the current mode.  
\* To enter the code registration mode, you need to press **FUNCTION** and **DISPLAY** at the same time.
- 18 **LIGHT ☼ :** When this button is pressed, some buttons (for example, **VOL +/-** and **CH ^ / v**) on the remote control unit will light. The lighting will turn off if no operations are performed within about 5 seconds. This button is used for performing operations in low-light situations.
- 19 **VIEW MODE:** Select the screen size.
- 20 **ENT:** Jumps to a channel after selecting with the **0-9** buttons.
- 21 **FLASHBACK:** Return to the previous channel or external input mode.
- 22 **CH ^ / v :** Select the channel.
- 23 **MUTE:** Mute the sound.
- 24 **MENU:** Display the menu screen.
- 25 **▲ / ▼ / ◀ / ▶ , ENTER:** Select a desired item on the screen.
- 26 **RETURN:** Return to the previous menu screen.
- 27 **FAVORITE CH**  
**A, B, C, D:** Select 4 preset favorite channels in 4 different categories.  
While watching, you can toggle the selected channels by pressing **A, B, C** and **D**.
- 28 **FAVORITE:** Set the favorite channels.
- 29 **CC:** Display captions from a closed-caption source.
- 30 **AV MODE:** Select an audio or video setting.  
(When the input source is TV, INPUT 1, 2 or 3: STANDARD, MOVIE, GAME, USER, AUTO, DYNAMIC (Fixed), DYNAMIC.  
When the input source is INPUT 4, 5, 6, 7 or 8: STANDARD, MOVIE, GAME, PC, USER, AUTO, DYNAMIC (Fixed), DYNAMIC)

## 2. Remote Control Unit (LC-C6077UN/LC-C6577UM)

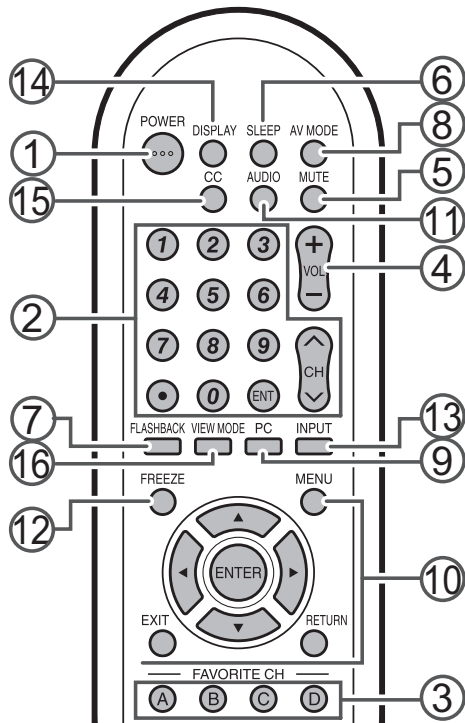

### ① POWER

You can turn on the TV or put it on standby by pressing **POWER** on the TV or on the remote control unit.

### ② Changing Channels

You can change channels by pressing **CH**  $\wedge/\vee$  or **0-9**, • (DOT).

#### Examples:

To select a 1 or 2-digit channel number (e.g., Channel 5):  
Press **5**  $\rightarrow$  **ENT**.

To select a 3-digit channel number (e.g., Channel 115):  
Press **1**  $\rightarrow$  **1**  $\rightarrow$  **5**  $\rightarrow$  **ENT**.

To select a 4-digit channel number (e.g., Channel 22.1):  
Press **2**  $\rightarrow$  **2**  $\rightarrow$  • (DOT)  $\rightarrow$  **1**  $\rightarrow$  **ENT**.

#### NOTE

- When selecting a 1-digit channel number, it is not necessary to press **0** before the number.
- When you enter **0-9** only, channel selection will be made if there is no operation within a few seconds.
- If you push "0" by itself, nothing will happen.
- Complete the above steps within a few seconds.
- When you enter **0-9** and • (DOT), channel selection will be made if there is no operation within a few seconds.

### ③ FAVORITE CH

You can select 4 preset favorite channels in 4 different categories.

Press **A**, **B**, **C** or **D**.

- While watching the TV, you can toggle the selected channels by pressing **A**, **B**, **C** and **D**.

#### NOTE

- Details of favorite channel settings.

### ④ Changing Volume

You can change the volume by pressing **VOL +/–** on the TV or on the remote control unit.

- To increase the volume, press **VOL +**.
- To decrease the volume, press **VOL –**.



#### Audio status

Output device	Output Select	
	Fixed	Variable
Speaker	Variable sound	Mute

- When "Output Select" is set to "Variable", the indicator on the screen changes as shown below.



#### NOTE

- Details on the Output Select function.

### ⑤ MUTE

Mutes the current sound output.

Press **MUTE**.

- "c" will be displayed on the screen for 30 minutes, and the sound is silenced.

#### NOTE

- Within 30 minutes of pressing **MUTE**, mute can be canceled by pressing **VOL +/-** or **MUTE**.
- Mute will be canceled after 30 minutes have passed. However, the TV will not suddenly output a loud sound as the volume level is set to 0 automatically.

### ⑥ Sleep Timer

Allows you to set a time when the TV automatically switches to standby.

Press **SLEEP**.

- The remaining time displays when the sleep timer has been set.
- Each time you press **SLEEP**, the remaining time switches as shown below.

Off  $\rightarrow$  30  $\rightarrow$  60  $\rightarrow$  90  $\rightarrow$  120

- When set, the time automatically starts counting down.
- If you want to adjust the sleep timer, you can press **SLEEP** twice then change the time setting.
- When it is 5 minutes before the time expires, the remaining time will start to keep appearing every minute.

#### NOTE

- Select "Off" by pressing **SLEEP** to cancel the sleep timer.
- The TV will enter standby when the remaining time reaches 0.
- When the sleep timer is set, its indicator on the TV lights red.

### ⑦ FLASHBACK

Press **FLASHBACK** to switch to the previously tuned channel.

- Press **FLASHBACK** again to switch back to the currently tuned channel.

#### NOTE

- **FLASHBACK** will not work if no channel has been changed after the TV is turned on.

## ⑧ AV MODE

AV MODE gives you several viewing options to choose from to best match the surrounding environment of the TV, which can vary due to factors like room brightness, type of program watched or the type of image input from external equipment.

Press **AV MODE**. Current AV MODE displays.

- Press **AV MODE** again before the mode displayed on the screen disappears. The mode changes as shown below:

### Example:

When the input source is TV, INPUT 1, 2 or 3 terminals

```

STANDARD → MOVIE → GAME → USER [TV]
    ↑
DYNAMIC ← DYNAMIC (Fixed) ← AUTO
  
```

### Example:

When the input source is INPUT 4, 5, 6, 7 or 8 terminals

```

STANDARD → MOVIE → GAME → PC → USER [ ]
    ↑
DYNAMIC ← DYNAMIC (Fixed) ← AUTO
  
```

**STANDARD:** For a highly defined image in a normal lighting.

**MOVIE:** For a movie.

**GAME:** Lowers image brightness for easier viewing.

**PC:** For PC.

**USER:** Allows the user to customize settings as desired. You can set the mode for each input source.

**AUTO:** Optimizes the image quality automatically based on the room brightness and image signal.

**DYNAMIC (Fixed):** Changes the image and sound settings to the factory preset values. No adjustments are allowed.

**DYNAMIC:** For a clear-cut image emphasizing high contrast, useful for sports viewing.

### NOTE

- You can select a different AV MODE item for each input mode. (For example, select STANDARD for TV input and DYNAMIC for INPUT 1.)
- When you play games, "GAME" is recommended for AV MODE.
- When AV MODE is set to "AUTO", part of the menu may not be displayed correctly or the setting range of the menu may be changed.

## ⑨ PC

Allows you to gain quick access to PC mode. Press **PC**.

## ⑩ Operating On-Screen Display Menu

You can operate the on-screen display menu by using the following buttons.

**MENU:** Displays the menu screen.

**▲ / ▼ / ◀ / ▶, ENTER:** Select a desired item on the screen.

**RETURN:** Returns to the previous menu screen.

**EXIT:** Turns off the menu screen.

### NOTE

- For operating the on-screen display menu, see "Menu Operation Buttons"

## ⑪ AUDIO

### ■ MTS/SAP stereo mode

The TV has a feature that allows reception of sound other than the main audio for the program. This feature is called Multi-channel Television Sound (MTS). The TV with MTS can receive mono sound, stereo sound and Secondary Audio Programs (SAP). The SAP feature allows a TV station to broadcast other information, which could be audio in another language or something completely different like weather information.

### You can enjoy Hi-Fi stereo sound or SAP broadcasts where available.

- **Stereo broadcasts:** View programs like live sporting events, shows and concerts in dynamic stereo sound.
- **SAP broadcasts:** Receive TV broadcasts in either MAIN or SAP sound. MAIN sound: The normal program soundtrack (either in mono or stereo). SAP sound: Listen to a second language, supplementary commentary or other information. (SAP is mono sound.)

### If stereo sound is difficult to hear.

- Obtain a clearer sound by manually switching to fixed mono-sound mode.

You can change MTS as shown below to match the television broadcast signal.

Press **AUDIO** to toggle between audio modes.

### Examples: when receiving MTS and SAP

```

STEREO mode: STEREO ↔ MONO
STEREO + SAP mode: ST(SAP) → SAP(ST) → MONO
                    ↑
MAIN + SAP mode: MAIN ↔ SAP
MONO mode: MONO
  
```

### ■ Digital broadcasting audio mode

The types of audio transmitted in a digital broadcast include SURROUND as well as MONO and STEREO. In addition, it is possible for multiple audio tracks to accompany a single video track.

Press **AUDIO** to toggle between audio modes.

### Example: when receiving Digital broadcasting

```

STEREO (Audio1) → STEREO (Audio2)
                ↑
                SURROUND (Audio3)
  
```

### NOTE

- MTS only operates while in TV mode.

## ⑫ FREEZE

Allows you to capture and freeze a moving image that you are watching.

Press **FREEZE**.

- A moving image is captured.
- Press **FREEZE** again to cancel the function.

### NOTE

- When this function is not available, "No displaying still image available." will display.
- The still image automatically goes out after 30 minutes.
- If you are using the freeze function and a broadcast activates the V-CHIP BLOCK, the freeze function will be canceled and a V-CHIP BLOCK message will appear.

### 13 INPUT

To view external source images, select the input source using **INPUT** on the remote control unit or on the TV.

**1 Press INPUT.**

- A list of selectable sources appears.

**2 Press INPUT again or press ▲/▼ to select the input source.**

- An image from the selected source automatically displays.
- Each time **INPUT** is pressed, the input source toggles.
- If the corresponding input is not plugged in, you cannot change the input. Be sure to connect the equipment beforehand.

**NOTE**

- External equipment connection.
- Press **PC** to switch to an image from the PC.

### 14 DISPLAY

Displays channel information being viewed. Press **DISPLAY**.

### 15 Closed Captions and Digital Closed Captions

Your TV is equipped with an internal Closed Caption decoder. It allows you to view conversations, narration and sound effects as subtitles on your TV. Closed Captions are available on some TV programs and on some VHS home video tapes at the discretion of the program provider.

Digital Closed Caption service is a new caption service available only on digital TV programs (also at the discretion of the service provider). It is a more flexible system than the original Closed Caption system, because it allows for a variety of caption sizes and font styles. When the Digital Closed Caption service is in use, it will be indicated by the appearance of a 3-letter abbreviation that also indicates the language of the Digital Closed Captions: ENG (English), SPA (Spanish), FRA (French) or other language codes.

Not all programs and VHS videotapes offer closed captions. Please look for the **CC** symbol to ensure that captions will be shown.

In the Closed Caption system, there can be more than one caption service provided. Each is identified by its own number. The "CC1" and "CC2" services display subtitles of TV programs superimposed over the program's picture.

In the Closed Caption system, the "Text1" or "Text2" services display text that is unrelated to the program being viewed (e.g., weather or news). These services are also superimposed over the program currently being viewed.

**1 Press CC.**

- This will present the Closed Caption information display.

**2 Press CC while the Closed Caption information is still on the screen.**

- Press repeatedly until you select the desired closed caption service.

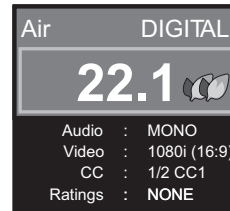

Closed Caption information

- Depending on the number of caption services in the signal being received, you will see information such as 1/2 or 1/4 displayed. 1/2 means "the first of two services".

**Example:**

If a program has three services (Digital CC(ENG), CC1 and Text1), the closed caption display will toggle in this sequence:

1/3 ENG → 2/3 CC1 → 3/3 Text1 → Off

- The **CC** button keeps a record of the last service selected in its memory. If the last closed caption mode (e.g. 1/3ENG) you selected is not available for the next program, or on another channel, the closed caption service that is available is automatically selected, and this service appears in parentheses, e.g. "1/3(CC1)". Closed Caption services that appear in parentheses will not be stored in the **CC** button's memory as your last selected service. Only services that you have selected with the **CC** button are stored.

**Examples:**

In a case where there are two closed caption services provided (for instance, Digital CC(ENG) and CC1), and Digital CC(ENG) is displayed as your current selection, if Digital CC(ENG) is not broadcast for the next program, the other closed caption service, CC1, will be displayed in parentheses. A closed caption service appears in parentheses because the service you selected is not available and a different service is displayed on your screen. "1/1(CC1)" is displayed instead of "1/2/ENG".

**NOTE**

- When "Power Saving" is set to "Standard" or "Advanced", the Power Saving leaf icon appears on the channel information window. Details of Power Saving settings.
- Detailed closed caption settings.
- When the program contains no closed caption, "--" displays in the closed caption information.
- If the language code, e.g. "ENG", is not found on Digital TV programs, "--" will be shown.
- Four kinds of closed caption service (CC1, CC2, Text1, Text2) are potentially available, but a broadcast may contain none or only some of these services at the discretion of the program provider.

**16 VIEW MODE**

You can select the screen size.

**1 Press VIEW MODE.**

- The View Mode menu displays.
- The menu lists the View Mode options selectable for the type of video signal currently being received.

**2 Press VIEW MODE or ▲/▼ while the View Mode menu is displayed to select a desired item on the menu.**

- You can sequentially select a View Mode that has its own aspect ratio.

**■ For 4:3 programs**

**Example: Screen size images**

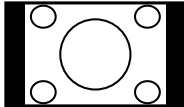
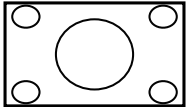
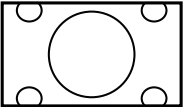
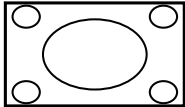
Side Bar	S.Stretch (Smart stretch)	Zoom	Stretch
 <p>Suitable for viewing conventional 4:3 programs in their normal format.</p>	 <p>Suitable for stretching 4:3 programs to fill the screen.</p>	 <p>Suitable for viewing wide-screen 2.35:1 anamorphic DVDs in full screen.</p>	 <p>This mode is useful for 1.78:1 DVDs. When viewing 1.85:1 DVDs, stretch mode will still show very thin black bands at the top and bottom of the screen.</p>

**■ For HD programs**

**Stretch:** Suitable for viewing wide-screen 1.78:1 aspect ratio program, stretch mode will still show very thin black bands at the top and bottom of the screen.

**Dot by Dot (1080i/p only):** Detects the resolution of the signal and displays an image with the same number of pixels on the screen.

**Full Screen (720p only):** You can select "Full Screen" only when receiving a 720p signal.

**S.Stretch (Smart stretch):** Suitable for stretching 4:3 programs to fill the screen.

**Zoom:** Suitable for viewing wide-screen 2.35:1 aspect-ratio programs in full screen.

**NOTE**

- When using Dot by Dot or Full Screen, it is possible to see noise or bars around different outer portions of the screen. Please change view mode to correct this.

**■ For PC input mode**

**NOTE**

- Connect the PC before making adjustments.
- Selectable screen size may vary with input signal type.

**Example: Screen size images**

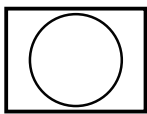
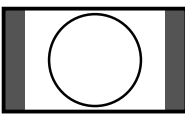
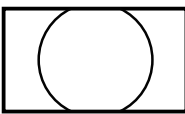
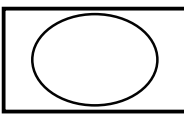
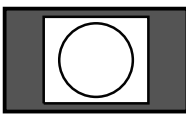
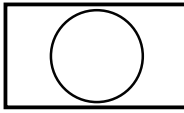
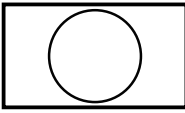
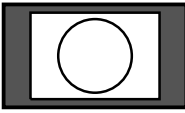
<p><b>Input signal</b></p>  <p>4:3</p>	<p><b>Normal</b></p>  <p>Keeps the original aspect ratio in a full screen display.</p>	<p><b>Zoom</b></p>  <p>For viewing widescreen programs. The top and bottom of the image is cropped.</p>	<p><b>Stretch</b></p>  <p>An image fully fills the screen.</p>	<p><b>Dot by Dot</b></p>  <p>Detects the resolution of the signal and displays an image with the same number of pixels on the screen.</p>
<p><b>Input signal</b></p>  <p>16:9</p>	<p><b>Stretch</b></p>  <p>An image fully fills the screen.</p>	<p><b>Dot by Dot</b></p>  <p>Detects the resolution of the signal and displays an image with the same number of pixels on the screen.</p>		

# CHAPTER 3. DIMENSIONS

## [1] DIMENSIONS (LC-60E77UN/LC-C6077UN)

Unit: inch (mm)

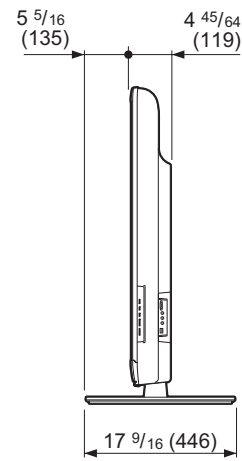
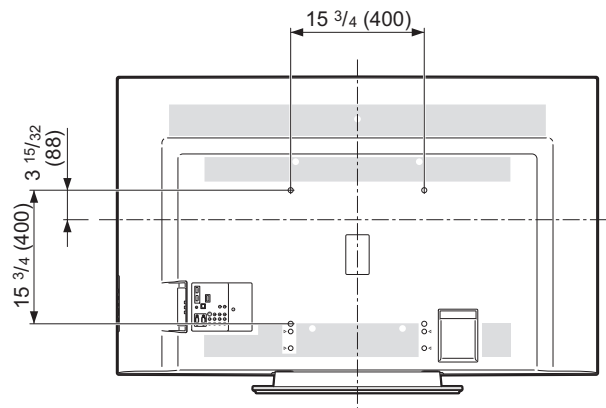
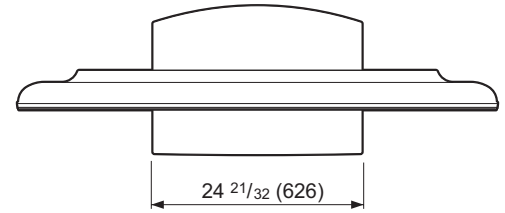
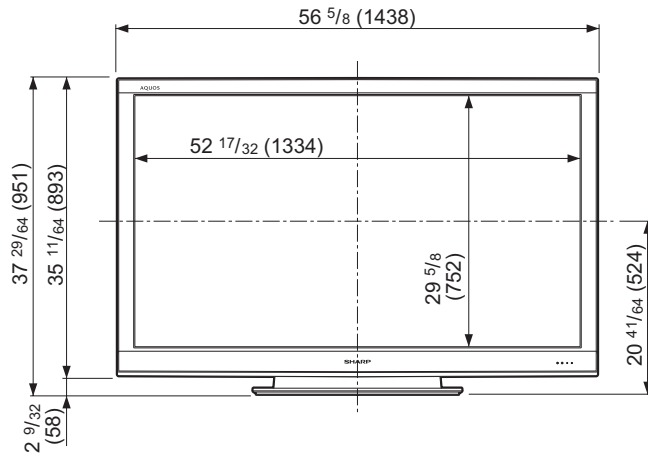

**AN-52AG4**

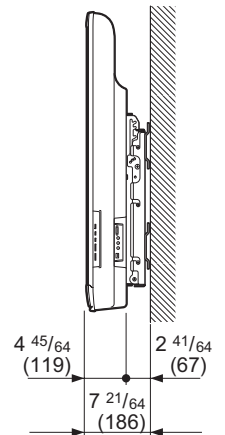

[2] DIMENSIONS (LC-65E77UM/LC-C6577UM)

Unit: inch (mm)

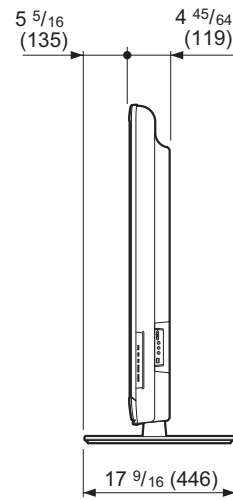
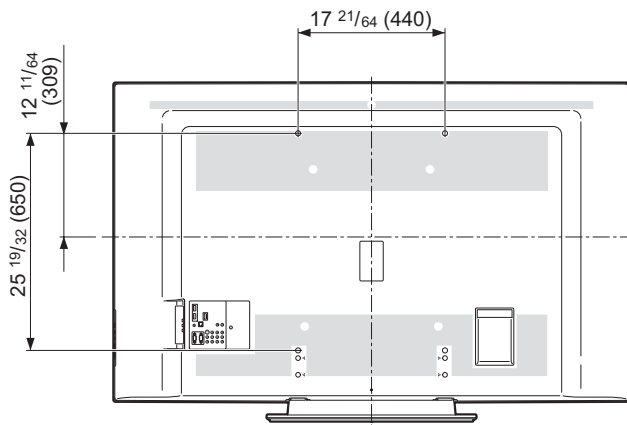
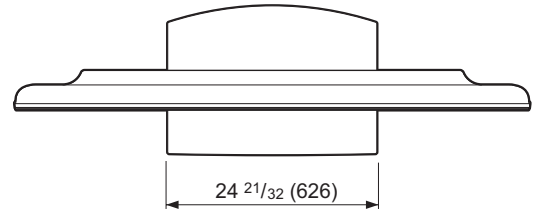
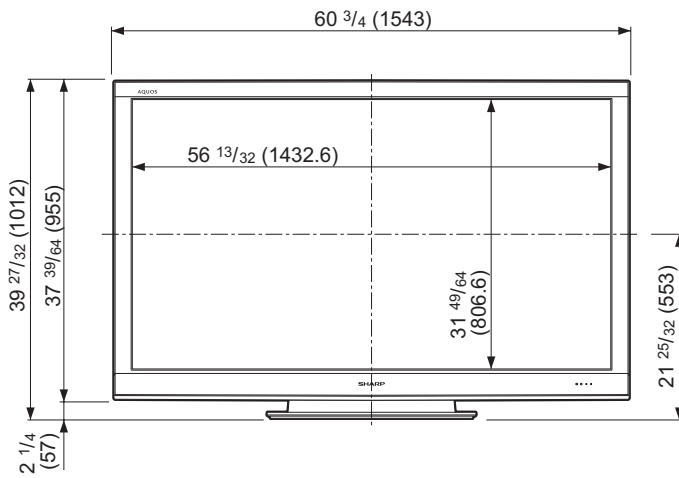

**AN-65AG1**

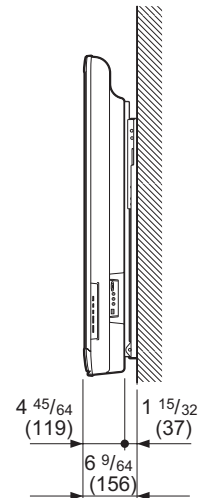

## CHAPTER 4. REMOVING OF MAJOR PARTS

### [1] REMOVING OF MAJOR PARTS (LC-60E77UN/LC-C6077UN)

#### 1. Removing of Stand Unit and Rear Cabinet Ass'y.

1. Remove the 4 lock screws ① and detach the Stand Unit ②.
2. Remove the 3 lock screws ③, 1 lock screw ④, 18 lock screws ⑤ and detach the Rear Cabinet Ass'y.

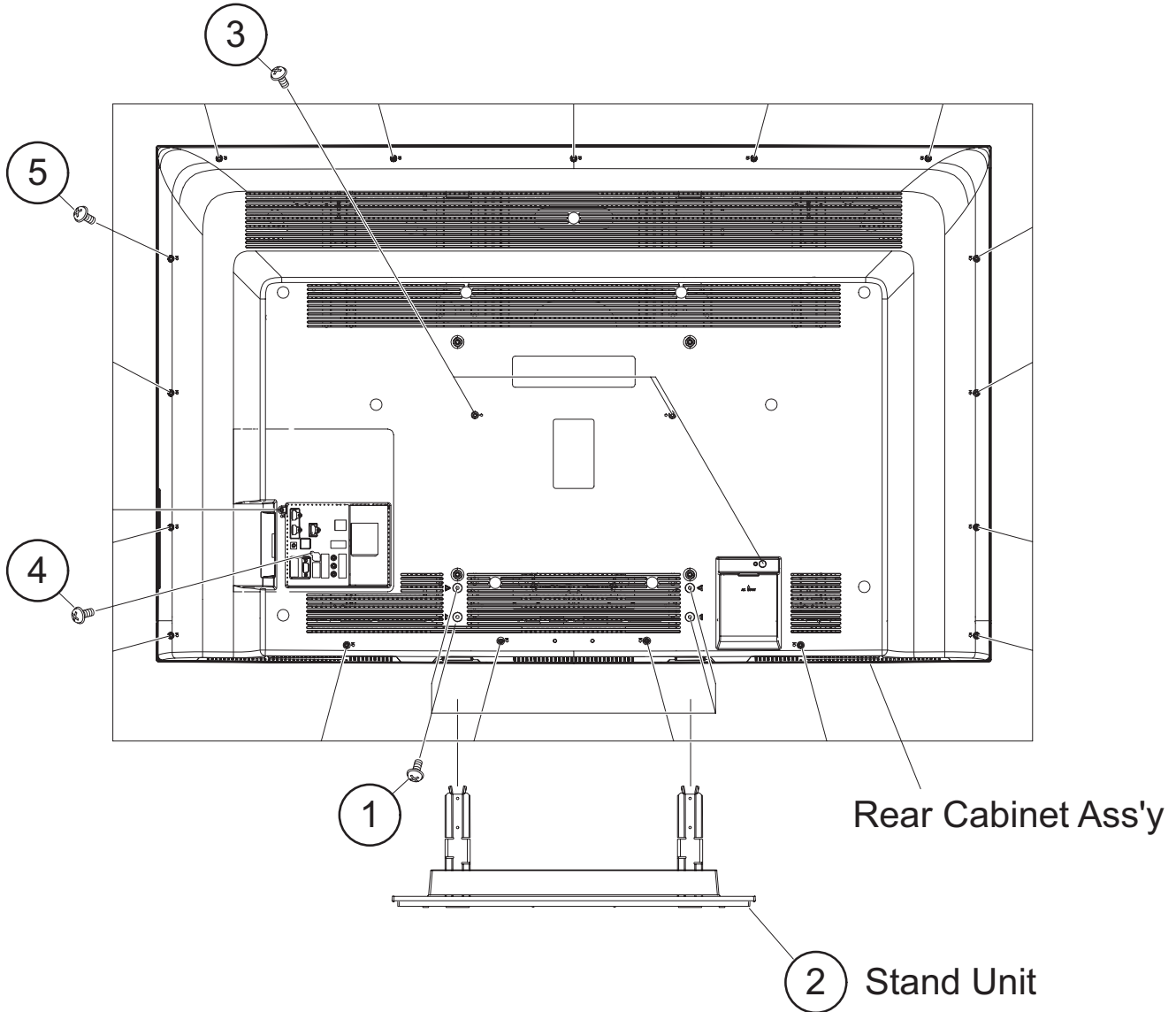

**2. Removing of Speaker-L/R, KEY Unit, R/C, LED Unit, Front Cabinet Ass'y.**

1. Disconnect the following connectors from the MAIN Unit. (RA, SP)
2. Detach the Speaker-L/R ①.
3. Disconnect the KEY Unit ③ from the KEY Button Cover Ass'y ② and disconnect the connection cord from the KM Connector.
4. Detach the R/C, LED Unit ④. (RA)
5. Remove the 4 lock screws ⑤ and 10 Hooks and detach the Front Cabinet Ass'y

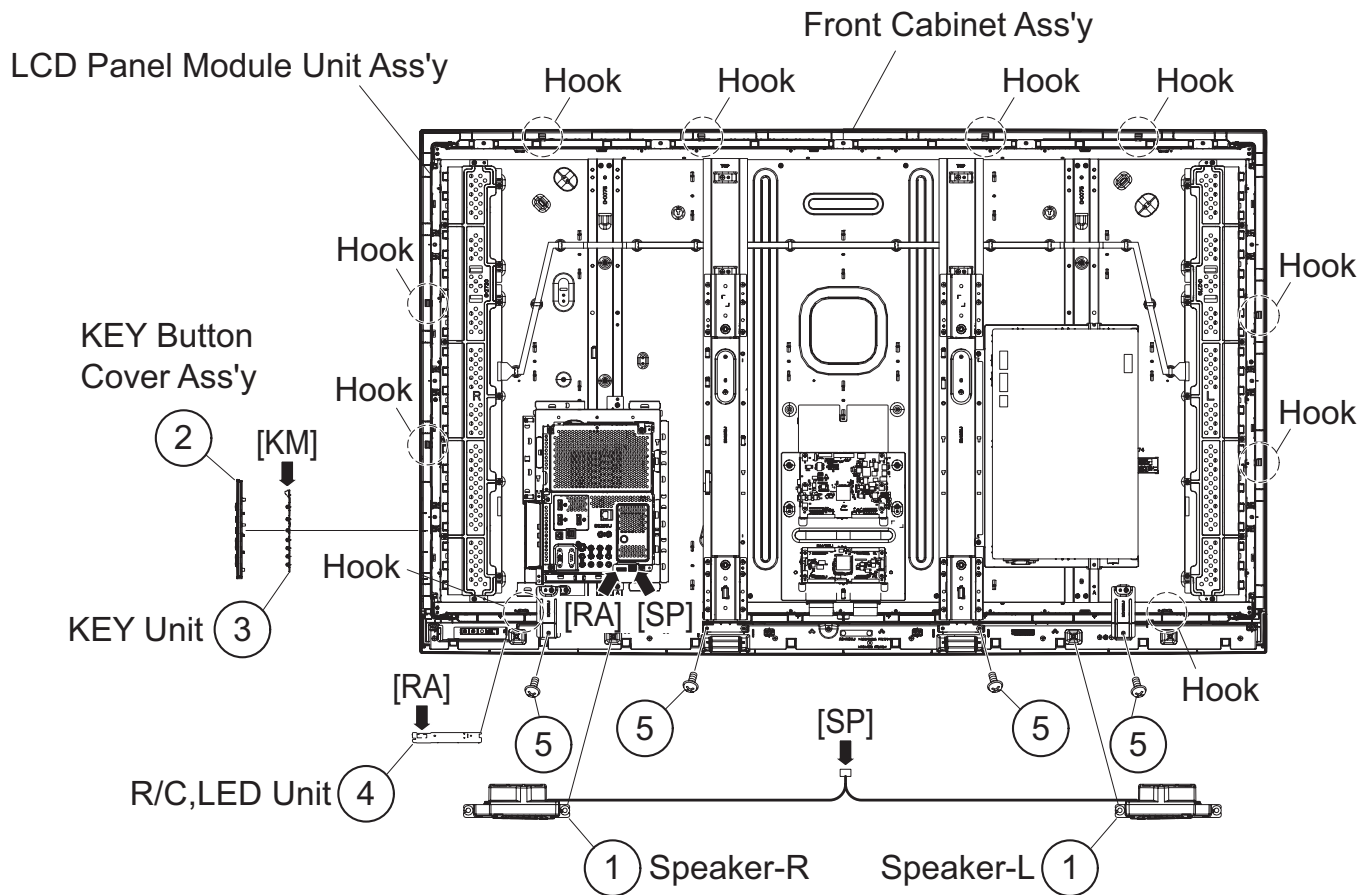

**3. Removing of Connectors, Side Terminal Cover Ass'y, MAIN PWB Shield.**

1. Remove the 3 lock screws ①, Side Terminal Cover Ass'y ②, 2 lock screws ③ and 4 lock screws ④ and detach the MAIN PWB Shield ⑤.
2. Disconnect the following connectors from the MAIN Unit. (LB1, PD, LP, LW, KM)
3. Disconnect the following connectors from the LCD Control Unit and FPGA Unit. (LW, PL, LP)
4. Disconnect the following connectors from the POWER Unit. (LA2, LA1, PD, PL)

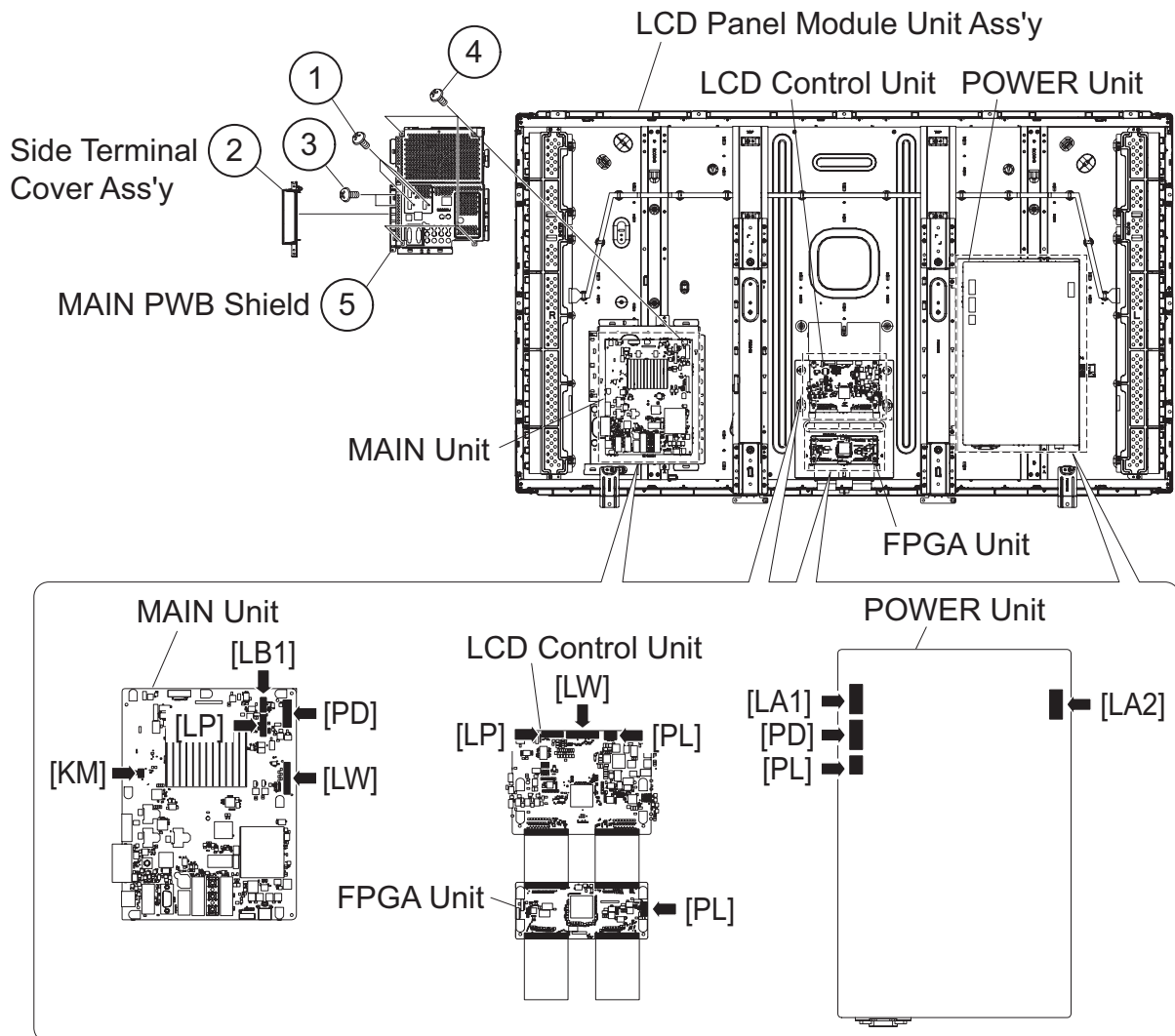

**4. Removing of MAIN Unit, FPGA Unit, LCD Control Unit and POWER Unit.**

1. Remove the 4 lock screws ① and detach the MAIN Unit ②.
2. Remove the 3 lock screws ③, 2 lock screws ④ and 2 Panel Lug ⑤ and detach the MAIN PWB Angle ⑥.
3. Remove the 4 lock screws ⑦ and detach the FPGA Unit ⑧.
4. Remove the 4 lock screws ⑨ and detach the LCD Control Unit ⑩.
5. Remove the 2 lock screws ⑪ and 4 lock screws ⑫ and detach the Control PWB Angle ⑬.
6. Remove the 8 lock screws ⑭ and 1 hook ⑮ and detach the POWER Unit ⑯.
7. Remove the 4 lock screws ⑰ and detach the POWER PWB Angle ⑱.

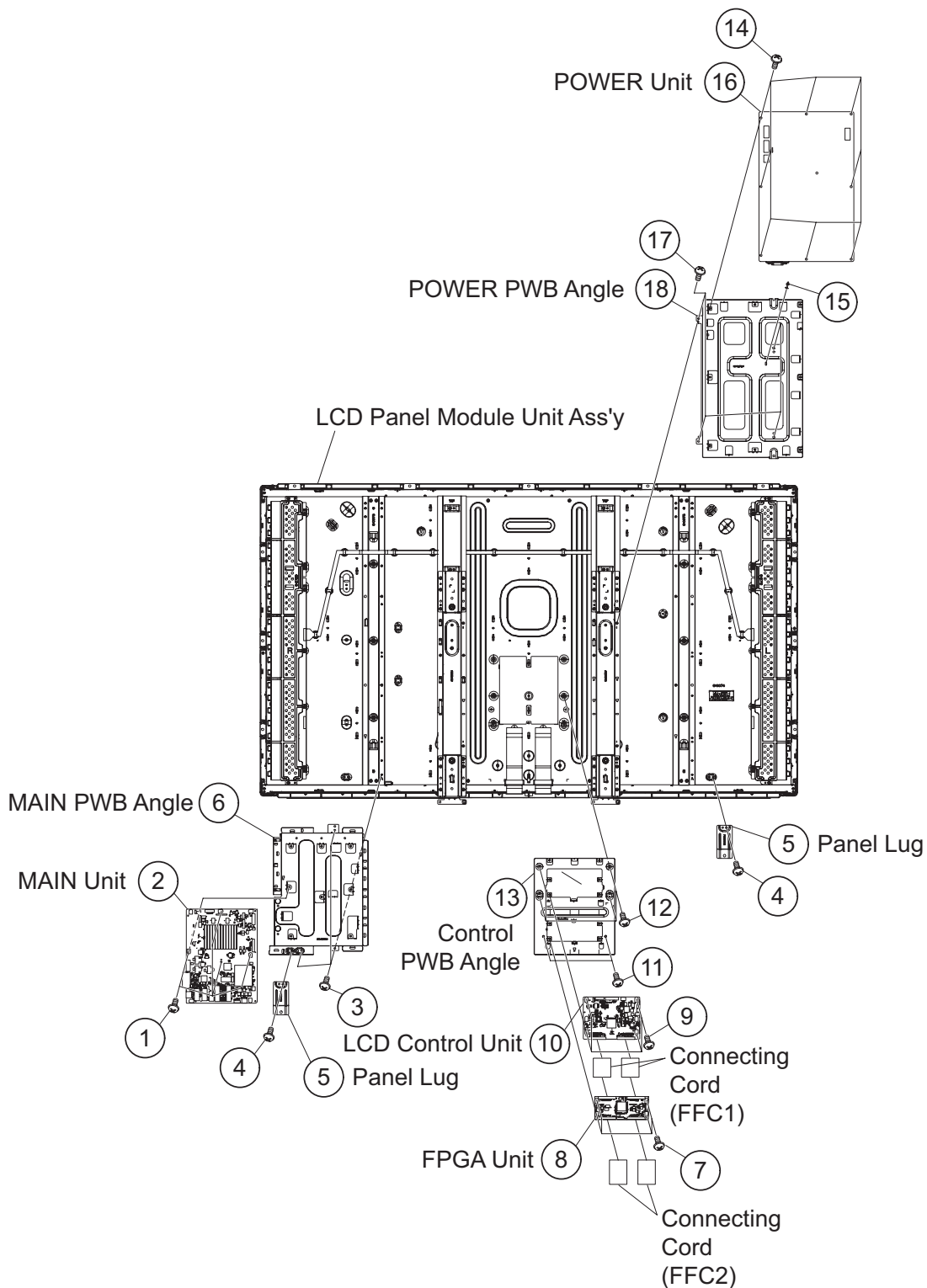

**5. Removing of VESA Angle and Support Angle.**

1. Remove the 20 lock screws ① and detach the 4 VESA Angle ②.
2. Remove the 10 lock screws ③ and detach the 2 Support Angle ④.

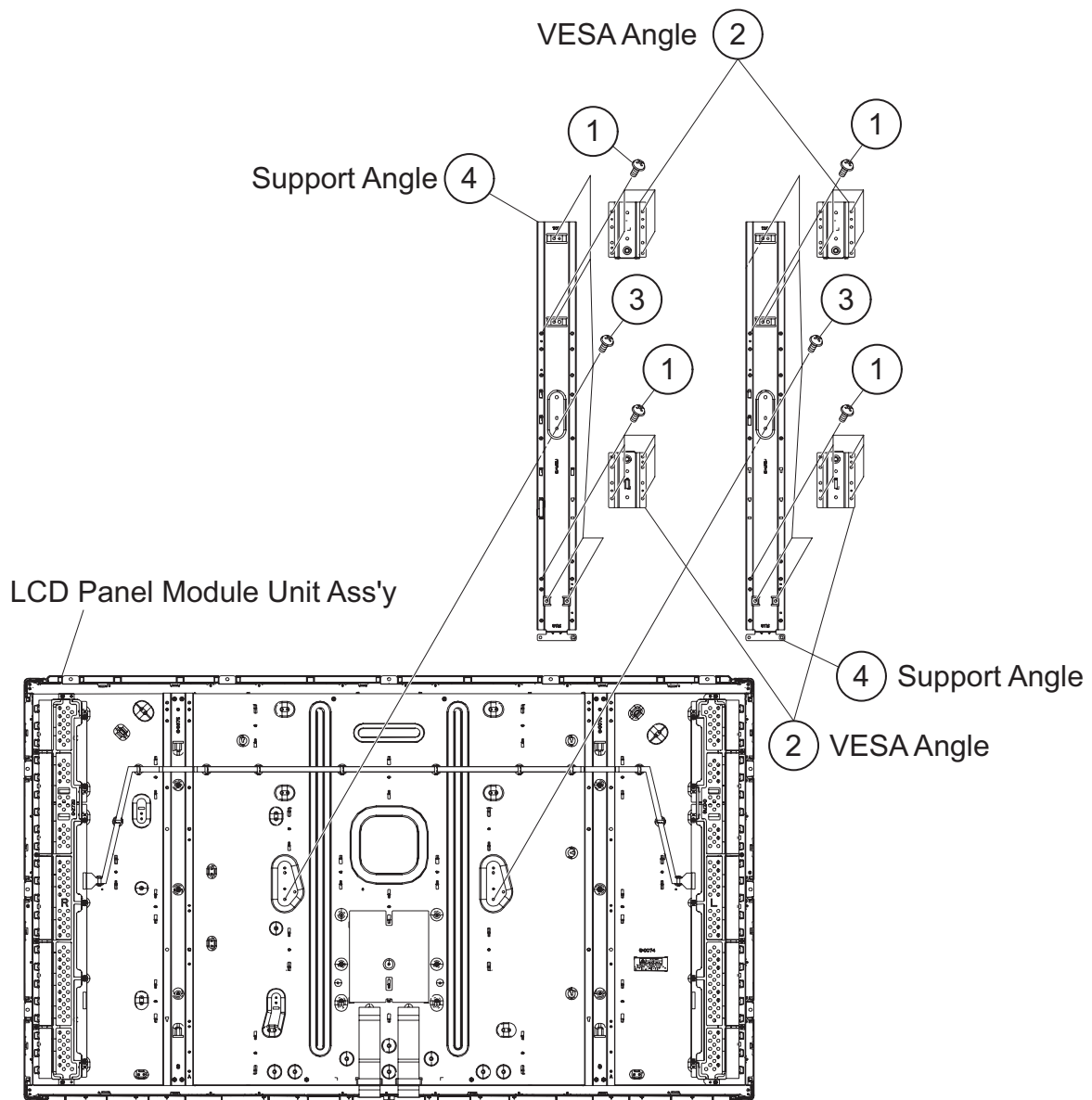

**6. Removing of Bezel Ass'y, Micro Lens Sheet, Diffusion Plate, Reflector Sheet, INVERTER Unit-1/2 and BL Chassis Ass'y.**

1. Remove the 28 lock screws ① and detach the Bezel Ass'y ②.
2. Detach the Micro Lens Sheet ③.
3. Detach the Diffusion Plate ④.
4. Detach the 2 Lamp Holder ⑤, 44 Socket ⑥ and 22 Lamp ⑦.
5. Detach the Reflector Sheet ⑧.
6. Remove the 12 lock screws ⑨ and detach the INVERTER Cover-L ⑩.
7. Detach the INVERTER Unit-1 ⑪.
8. Remove the 12 lock screws ⑫ and detach the INVERTER Cover-R ⑬.
9. Detach the INVERTER Unit-2 ⑭.
10. Detach the BL Chassis Ass'y ⑮.

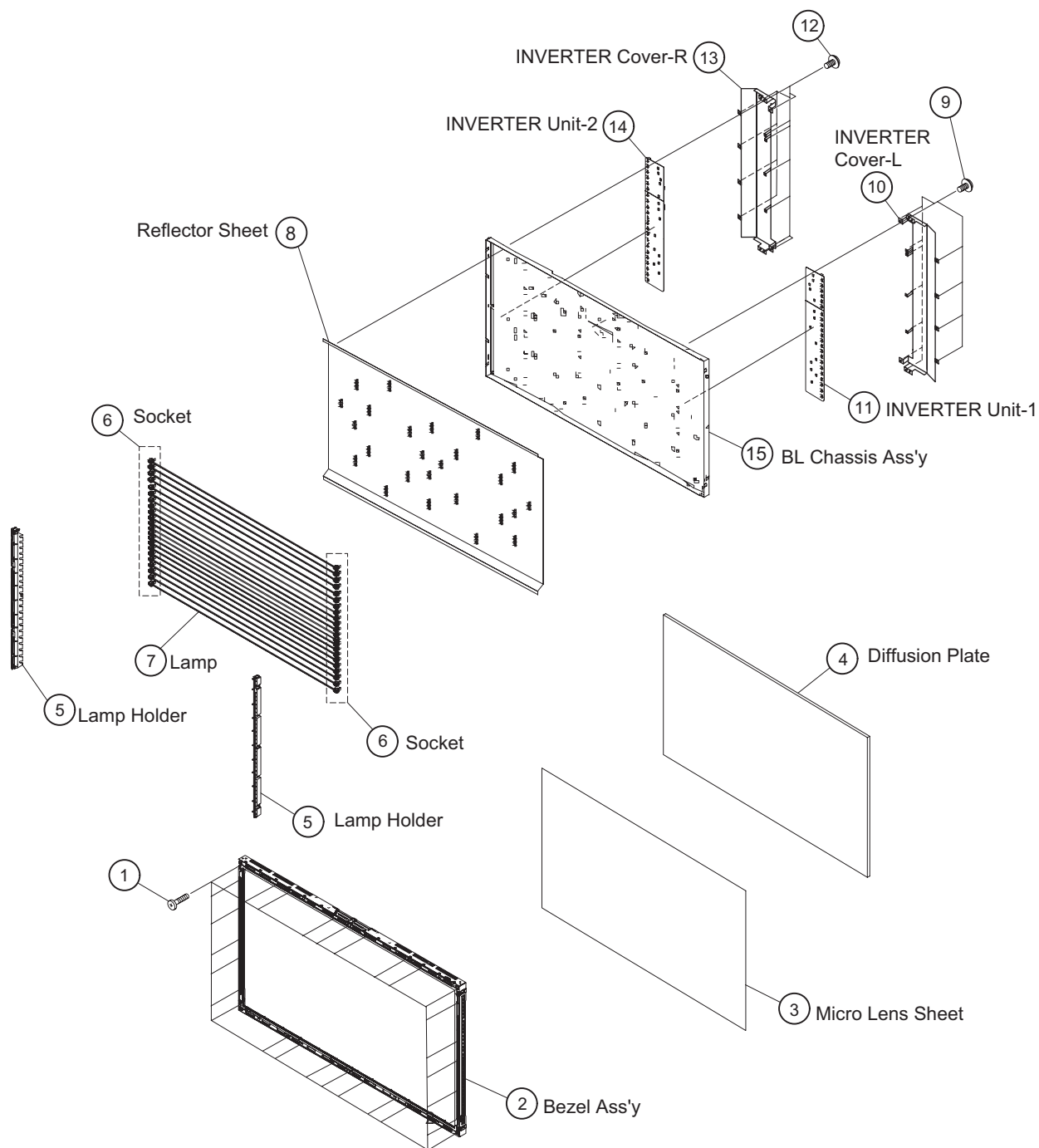

## [2] REMOVING OF MAJOR PARTS (LC-65E77UM/LC-C6577UM)

### 1. Removing of Stand Unit and Rear Cabinet Ass'y.

1. Remove the 4 lock screws ① and detach the Stand Unit ②.
2. Detach the 5 Spacers ③.
3. Remove the 2 lock screws ④, 1 lock screw ⑤, 16 lock screws ⑥ and detach the Rear Cabinet Ass'y.

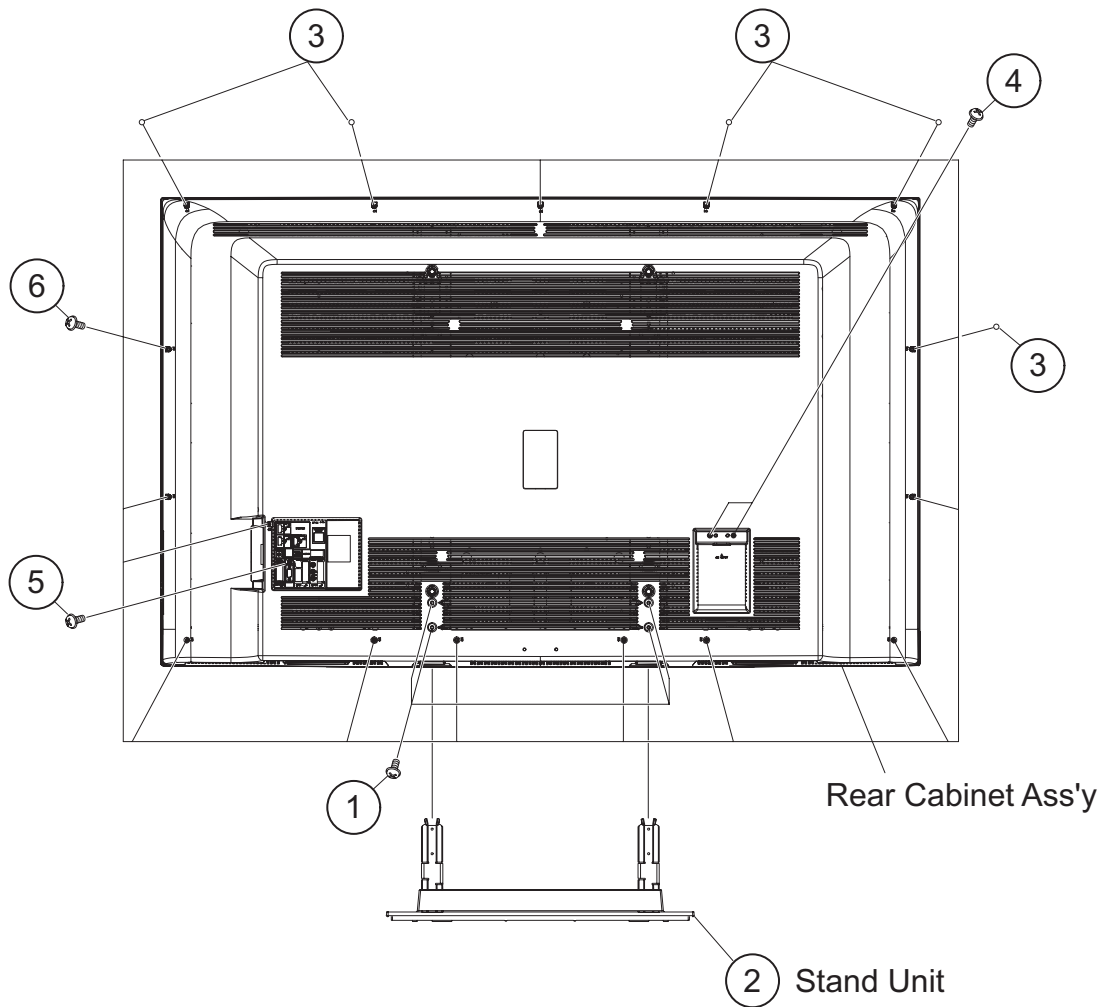

CAUTION: In the case of assembly, the new Spacer (PSPAGA386WJ00) can be stuck on a screw.

**2. Removing of Speaker-L/R, KEY Unit, R/C, LED Unit, Front Cabinet Ass'y.**

1. Disconnect the following connectors from the MAIN Unit. (RA, SP)
2. Detach the Speaker-L/R ①.
3. Disconnect the KEY Unit ③ from the KEY Button Cover Ass'y ② and disconnect the connection cord from the KM Connector.
4. Detach the R/C, LED Unit ④. (RA)
5. Remove the 2 lock screws ⑤ and 8 Hooks and detach the Front Cabinet Ass'y

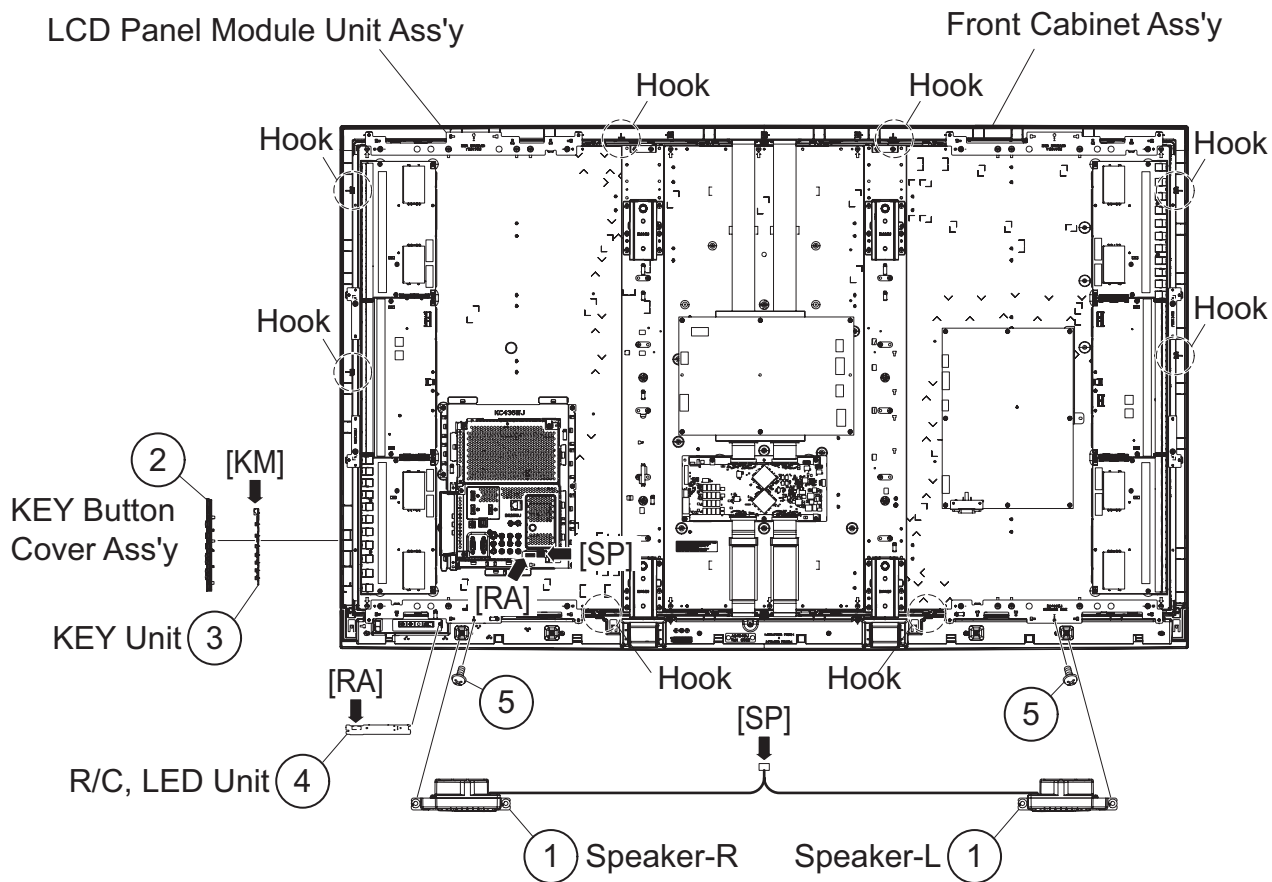

**3. Removing of Connectors, Side Terminal Cover Ass'y, MAIN PWB Shield.**

1. Remove the 3 lock screws ①, Side Terminal Cover Ass'y ②, 2 lock screws ③ and 4 lock screws ④ and detach the MAIN PWB Shield ⑤.
2. Disconnect the following connectors from the MAIN Unit. (LB1, PD, LW, LP, KM)
3. Disconnect the following connectors from the MAIN POWER Unit. (LA, PP1, PP2, PP3, PQ, PL, PD)
4. Disconnect the following connectors from the SUB POWER Unit. (PP1, PP2, PP3, PQ)
5. Disconnect the following connectors from the LCD Control Unit. (LW, FR)

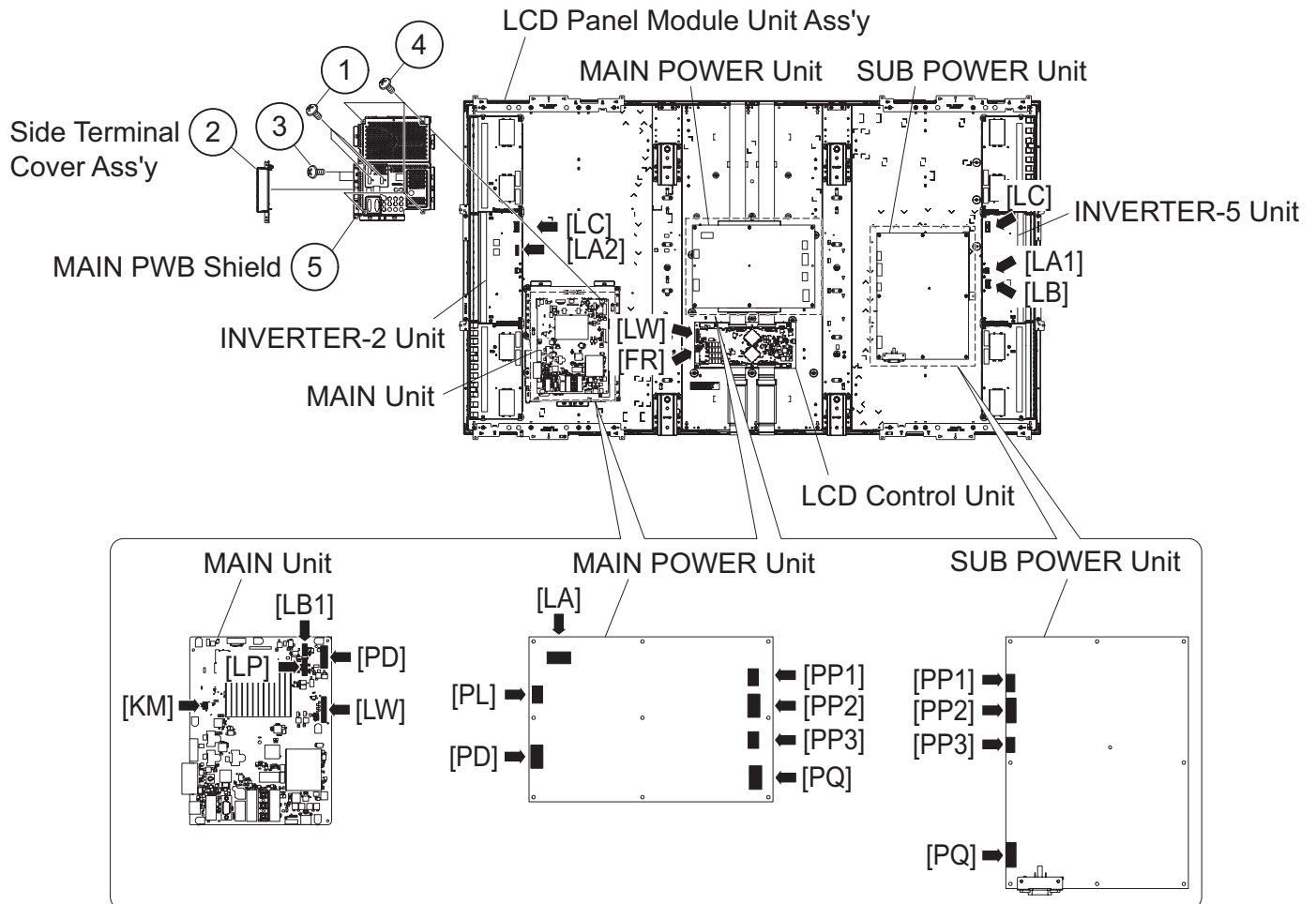

**4. Removing of MAIN Unit, MAIN POWER Unit, SUB POWER Unit.**

1. Remove the 4 lock screws ① and detach the MAIN Unit ②.
2. Remove the 6 lock screws ③ and detach the MAIN PWB Angle ④.
3. Remove the 6 lock screws ⑤, 3 Spacer ⑥ and detach the MAIN POWER Unit ⑦.
4. Detach the POWER2 Barrier ⑧.
5. Remove the 8 lock screws ⑨, 1 Spacer ⑩ and detach the SUB POWER Unit ⑪.
6. Detach the POWER1 Barrier ⑫.

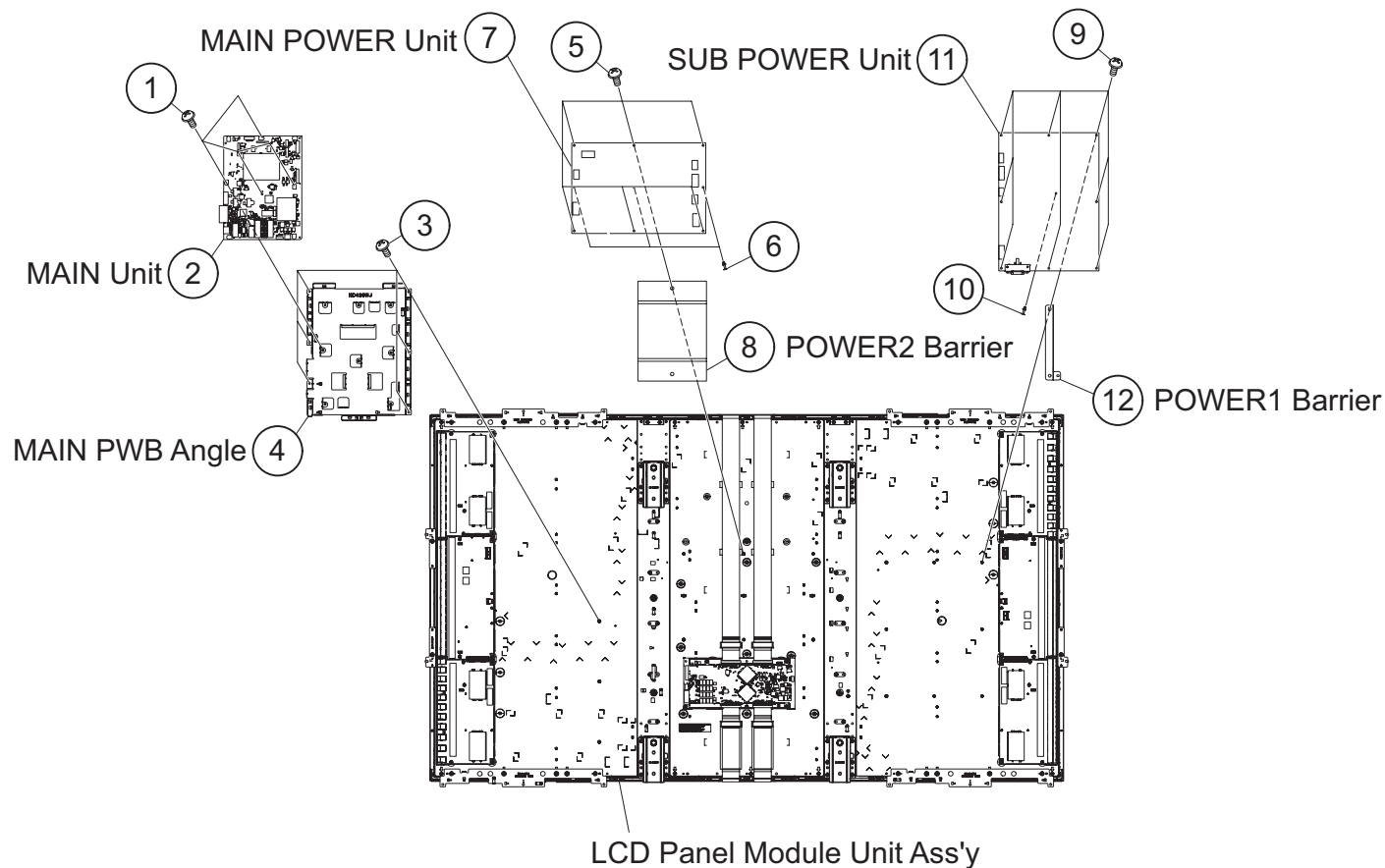

**5. Removing of Corner Lug and Side Lug.**

1. Remove the 8 lock screws ① and detach the 4 Corner Lug ②.
2. Remove the 4 lock screws ③ and detach the 4 Side Lug ④.

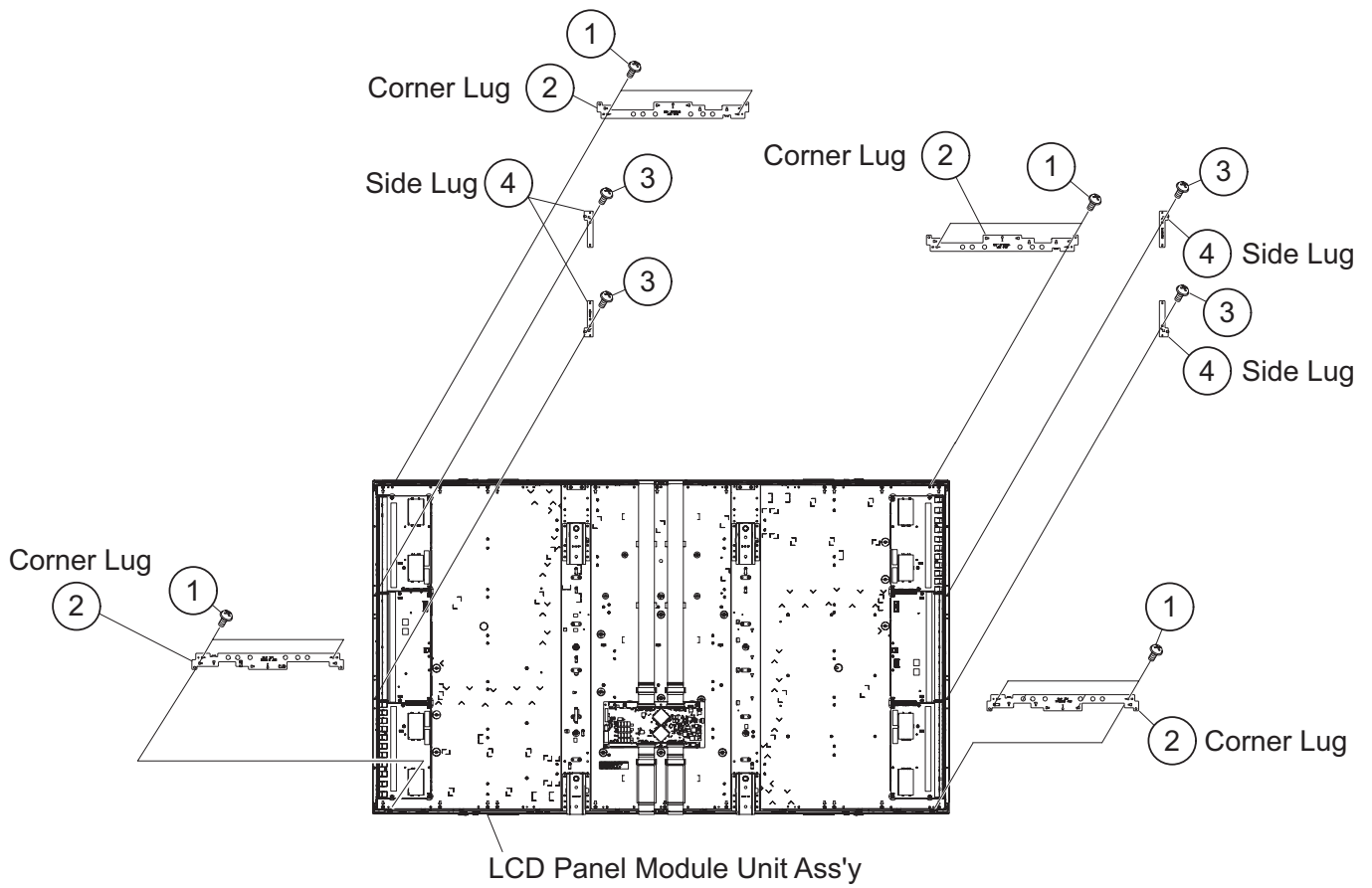

**6. Removing of Bezel Ass'y, Panel Chassis Ass'y, Lens Sheet, Diffusion Plate, Sheet suppression Angle (L/R, Top/Bottom), LCD Control Unit, INVERTER-1/2/3/4/5/6 and BL Chassis Ass'y.**

1. Remove the 26 lock screws ① and detach the Bezel Ass'y ②.
2. Remove the 2 lock screws ③ and detach the 2 Panel Guide Ass'y ④.
3. Remove the 26 lock screws ⑤ and detach the Panel Chassis Ass'y ⑥.
4. Detach the 2 Lens Sheet ⑦ and Diffusion Plate ⑧.
5. Remove the 8 lock screws ⑨ and detach the 2 Sheet suppression Angle (L/R) ⑩ and 2 Sheet Suppression Angle (Top/Bottom) ⑪.
6. Remove the 6 lock screws ⑫ and detach the 2 Lamp Holder ⑬.
7. Detach the 72 Socket ⑭ and detach the 36 Lamp ⑮.
8. Detach the Reflected Sheet ⑯.
9. Remove the 5 lock screws ⑰ and detach the LCD Control Unit ⑱.
10. Remove the 29 lock screws ⑲ and detach the INVERTER-1 Unit ⑳, INVERTER-2 Unit ㉑, INVERTER-3 Unit ㉒, INVERTER-4 Unit ㉓, INVERTER-5 Unit ㉔, INVERTER-6 Unit ㉕.
11. Detach the BL Chassis Ass'y ㉖.

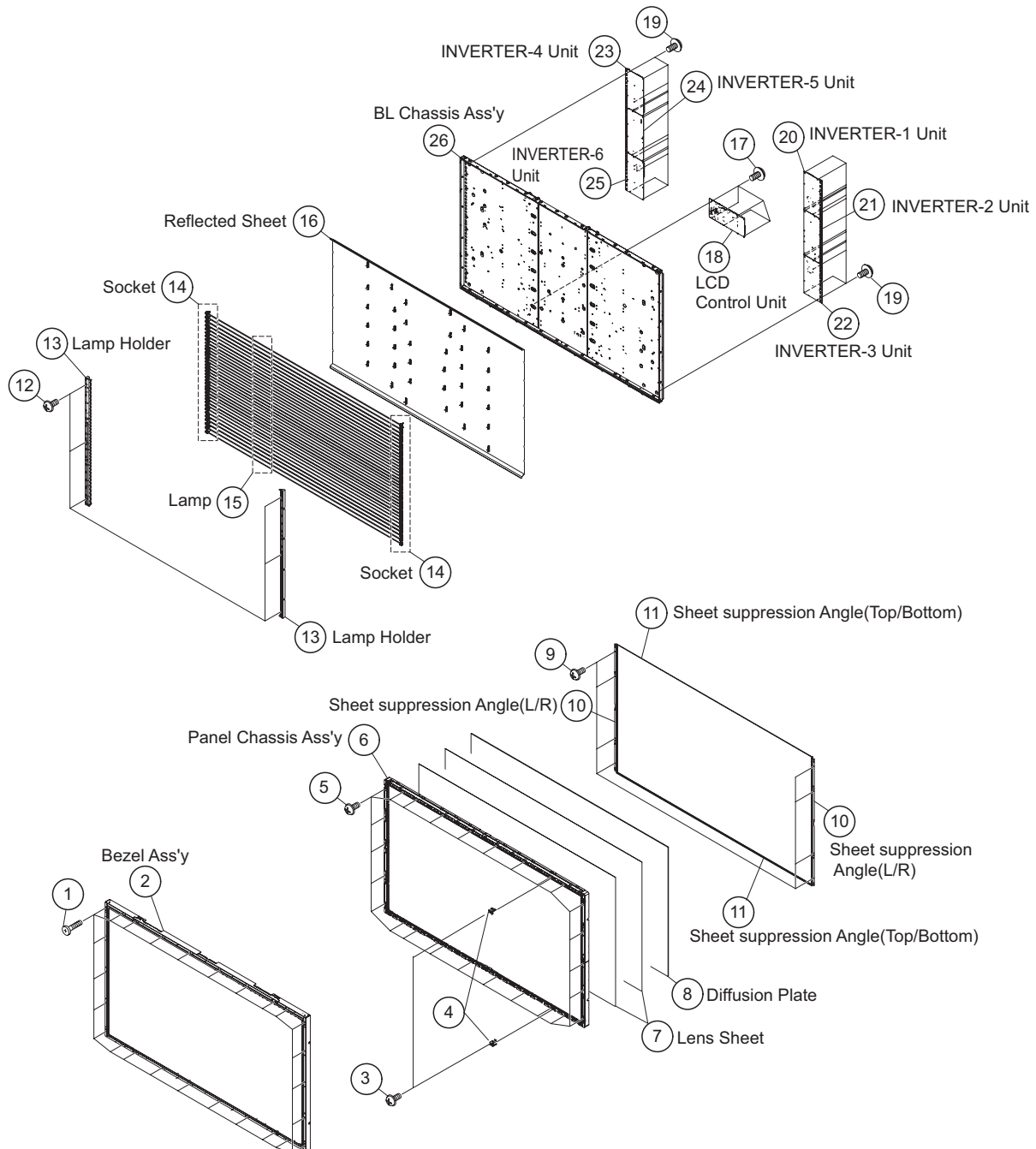

## CHAPTER 5. ADJUSTMENT

### [1] ADJUSTMENT PROCEDURE

The adjustment values are set to the optimum conditions at the factory before shipping. If a value should become improper or an adjustment is required due to part replacement, make an adjustment according to the following procedure.

#### 1. After replacement of any PWB unit and/or IC for repair, please note the following.

- When replacing the following units, make sure to prepare the new units loaded with updated software.

MAIN Unit: DUNTKF282FM06 (LC-60E77UN)  
DUNTKF282FM07 (LC-65E77UM)  
DUNTKF282FM11 (LC-C6077UN)  
DUNTKF282FM11 (LC-C6577UM)

- When replacing the LCD control PWB, perform the VCOM adjustment.

#### 2. Upgrading of each microprocessor software

CAUTION: Never "POWER OFF" the unit when software upgrade is ongoing.

Otherwise the system may be damaged beyond recovery.

##### 2.1. Software version upgrade

The model employs the following software.

- Main software (please use a software version after HLRCCxxx.USB).
- Monitor microprocessor software (please use a software version after HLRCCxxx.USB and HLNRMxxx.BIN.).

The main software, monitor microprocessor software can be upgraded by using a general-purpose USB Memory.

The followings are the procedures for upgrading, explained separately for the main software, monitor microprocessor software.

##### 2.2. Main software version upgrade

###### 2.2.1 Get ready before you start

- USB Memory of 128MB or higher capacity.
- PC running on Windows 98/98SE/ME/2000/XP operating system.
- USB Memory reader/writer or PC with a USB port.
- The file system of a USB memory is FAT (FAT32 supports).
- Use the USB memory without other functions (lock and memory reader...etc).

###### 2.2.2 Preparations

To upgrade the main software, it is necessary to get ready the USB Memory for version upgrade before you start.

Follow the steps below and create the USB Memory for version upgrade.

1. Copy the file HLRCCxxx.USB. for version upgrade to the root directory (folder) of the USB Memory.

NOTE: In the USB Memory drive, do not store other folders or unrelated files, or more than one file for version upgrade.

Now the USB Memory for version upgrade is ready.

**2.2.3 How to upgrade the software**

1. Unplug the AC cord.
2. Insert the USB Memory for version upgrade (prepared as above) into the service socket located Right side of Main Board terminals, under INPUT3 terminal.
3. Plug in the AC cord with power button pressed down after 5 seconds, unpress the power button.
4. After the unit startup, the system upgrade screen as shown below appears within 20-40 seconds.

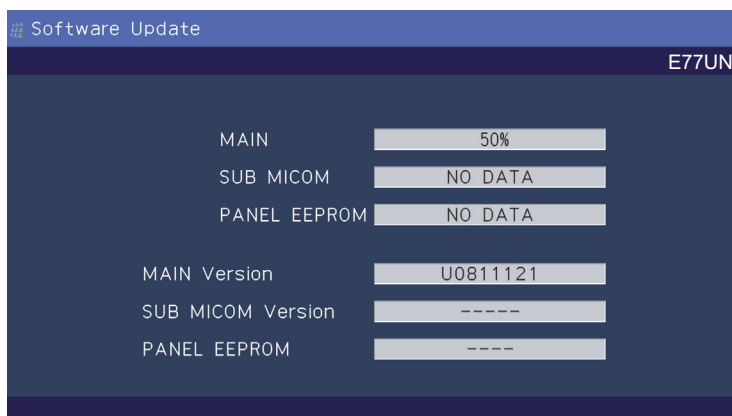

5. Even a single failure in the process will trigger the upgrade failure screen.

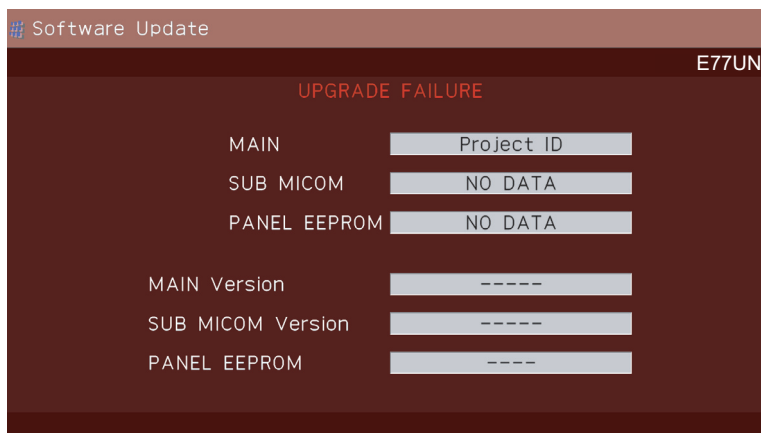

NOTE: In the event of a failure, repeat the upgrade process. If the process repeatedly fails, it is likely that the hardware need fixing.

6. Upon completion of the whole process, the upgrade success screen as shown below appears. You can check the new software version on this screen. The version information appears after the upgrade is complete.

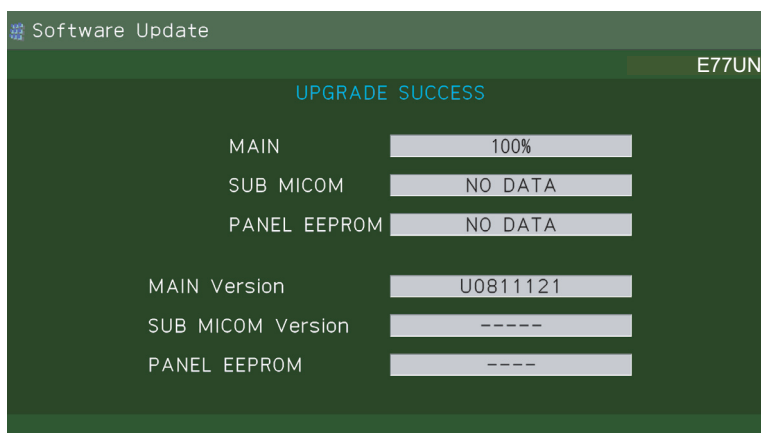

7. Unplug the AC cord and remove the USB Memory for version upgrade.
8. Now the software version upgrade is complete.

NOTE: When you are done with the software version upgrade, start the set, go to the top page of the adjustment process screen and check the main software version information.

### 2.3. Monitor microprocessor software version upgrade

Create the USB memory for monitor microprocessor software version upgrade in the same manner as explained in the "Main software version upgrade".

Copy the file HLRCCxxx.USB and HLNRMxxx.BIN (named temporarily) for monitor microprocessor software version upgrade to the USB memory.

#### 2.3.1 How to upgrade the software

1. Unplug the AC cord.
2. Insert the USB Memory for version upgrade (prepared as above) into the service socket located Right side of Main Board terminals, under INPUT3 terminal.
3. Plug in the AC cord with power button pressed down.
4. After 5 seconds, unpress the power button.

CAUTION: • The moment this operation is done, the upgrading of the monitor microprocessor software starts. While the upgrade is ongoing, never power off the unit. Otherwise the upgrade will fail and the system may be serious damaged beyond recovery (inability to start).

- After the monitor microprocessor software is upgraded, also perform the 'Industry Init'.

5. After the unit startup, the upgrade starts. The power led will blink continuously. Also, an upgrade screen will be shown during a minor upgrade.

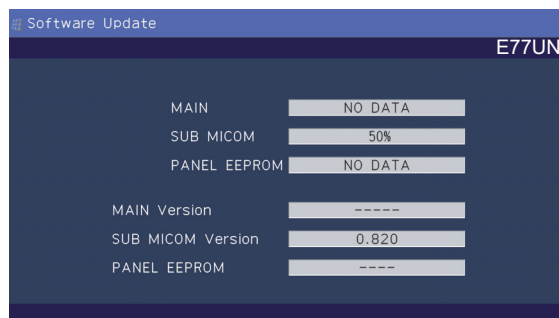

6. If the upgrade fails, power led will stop blinking. Also, the upgrade failure screen will be shown if upgrade screen was shown at 5.

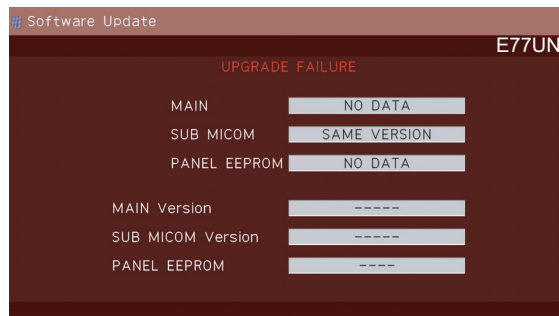

NOTE: In the event of a transient failure, upgrade will be automatically retried up to three times. If the process repeatedly fails, hardware may be the cause.

7. Up on completion of the whole process, power and OPC LED will blink alternately. Also, the upgrade success screen will be shown if upgrade screen was shown at 5.

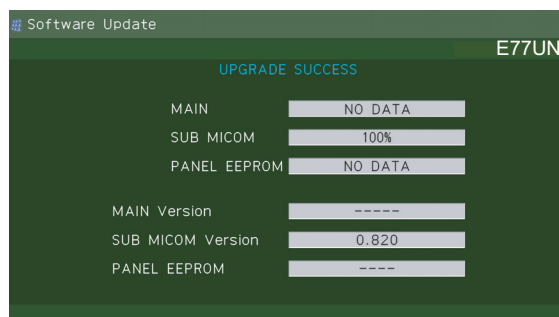

8. Unplug the AC cord and remove the USB Memory for version upgrade.
9. Now the software version upgrade is complete.

NOTE: When you are done with the software version upgrade, start the set, go to the top page of the adjustment process screen and check the monitor microprocessor software version information and panel size information.

### 3. Entering and exiting the adjustment process mode

- 1) Before entering the adjustment process mode, the AV position RESET in the video adjustment menu.
  - 2) While holding down the "VOL (-)" and "INPUT" keys at a time, plug in the AC cord of the main unit to turn on the power.  
The letter "<K>" appears on the screen.
  - 3) Next, hold down the "VOL (-)" and "CH (  $\surd$  )" keys at a time.  
(The "VOL (-)" and "CH (  $\surd$  )" keys should be pressed and held until the display appears.)  
Multiple lines of blue characters appearing on the display indicate that the unit is now in the adjustment process mode.  
When you fail to enter the adjustment process mode (the display is the same as normal startup), retry the procedure.
  - 4) To exit the adjustment process mode after the adjustment is done, unplug the AC cord from the outlet to make a forced shutdown. (When the power was turned off with the remote controller, once unplug the AC cord and plug it again. In this case, wait 10 seconds or so before plugging.)
- CAUTION: Use due care in handling the information described here lest your users should know how to enter the adjustment process mode. If the settings are tampered in this mode, unrecoverable system damage may result.

### 4. Remote controller key operation and description of display in adjustment process mode

- 1) Key operation

Remote controller key	Main unit key	Function
CH ( $\surd$ / $\wedge$ )	CH ( $\surd$ / $\wedge$ )	Moving an item (line) by one (UP/DOWN)
VOL (+/-)	VOL (+/-)	Changing a selected item setting (+1/ -1)
Cursor (UP/DOWN)	_____	Turing a page (PREVIOUS/NEXT)
Cursor (LEFT/RIGHT)	_____	Changing a selected line setting (+10/ -10)
INPUT	_____	Input switching (toggle switching)
ENTER	_____	Executing a function

\*Input mode is switched automatically when relevant adjustment is started so far as the necessary input signal is available.

- 2) Description of display

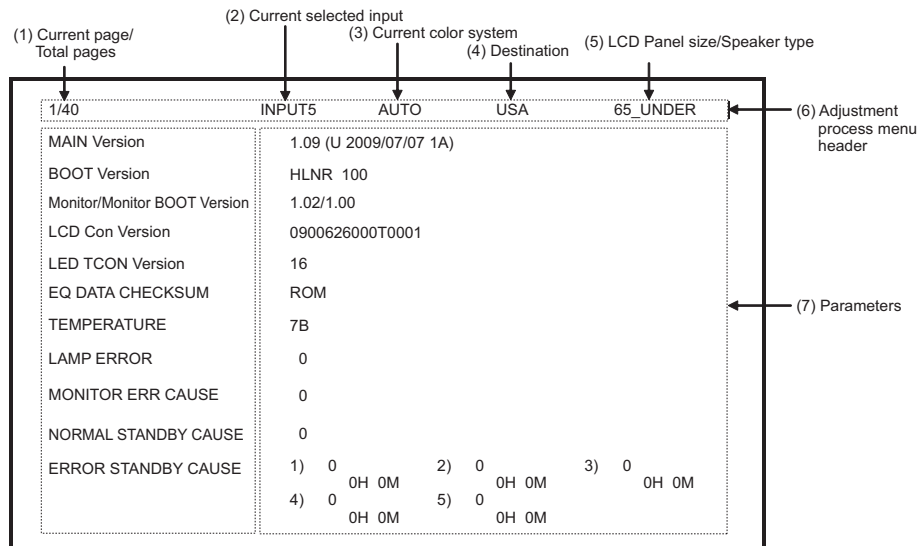

## 5. List of adjustment process mode menu

The character string in brackets [ ] will appear as a page title in the adjustment process menu header.

Page	Line	Item	Description	Remarks (adjustment detail, etc.)
1	1	MAIN Version	Main software version	Versions are always '090626000T0001'.  Refer to *1 under the list for details Refer to *2 under the list for details
	2	BOOT Version		
	3	Monitor/Monitor BOOT Version	Monitor and monitor boot software version	
	4	LCD Con Version	LCD controller software version	
	5	LED TCON Version		
	6	EQ DATA CHECKSUM	Audio data checksum	
	7	TEMPERATURE	Panel temperature	
	8	LAMP ERROR	Number of termination due to lamp error	
	9	MONITOR ERR CAUSE		
	10	NORMAL STANDBY CAUSE		
	11	ERROR STANDBY CAUSE		
2	1	INDUSTRY INIT	Initialization to factory settings	Level appears in green on the upper right
	2	INDUSTRY INIT(-Hotel)		
	3	PUBLIC MODE	Public mode	
	4	Center Acutime	Accumulated main operation time	
	5	RESET	Reset	
	6	Backlight Acutime	Accumulated monitor operation time	
	7	RESET	Reset	
	8	LAMP ERROR RESET	Reset LAMP ERROR	
	9	VIC XPOS	X-coordinate setting for VIC READ	
	10	VIC YPOS	Y-coordinate setting for VIC READ	
	11	VIC COLOR	Collected color data setting for VIC READ	
	12	VIC SIGNAL TYPE	Signal type setting for VIC READ	
	13	VIC READ	Picture level acquisition function	
3	1	N358 ALL ADJ(INPUT1)	CVBS and TUNER signal level adjustment	
	2	N358 ALL ADJ(INPUT3)		
	3	N358 MAIN ADJ(INPUT1)	CVBS signal level adjustment	
	4	N358 MAIN ADJ(INPUT3)		
	5	TUNER DAC ADJ	TUNER signal level adjustment	
	6	N358 CONTRAST A_GAIN		
	7	N358 CONTRAST D_GAIN		
	8	N358 CONTRAST OFFSET		
	9	TUNER CONTRAST A_GAIN		
	10	TUNER CONTRAST D_GAIN		
	11	TUNER CONTRAST OFFSET		
4	1	TUNER VCHIP TEST(69ch)	Tuning test and VCHIP test (69ch)	
	2	TUNER VCHIP TEST(7ch)	Tuning test and VCHIP test (7ch)	
	3	TUNER VCHIP TEST(10ch)	Tuning test and VCHIP test (10ch)	
	4	TUNER VCHIP TEST(15ch)	Tuning test and VCHIP test (15ch)	
	5	INSPECT USB TERM		
	6	HDMI EDID WRITE		
	7	HDMI CEC TEST		
5	1	COMP15K ADJ(INPUT1)	Component 15K picture level adjustment (main)	
	2	COMP15K ADJ(INPUT2)		
	3	COMP15K Y A_GAIN		
	4	COMP15K Cb A_GAIN		
	5	COMP15K Cr A_GAIN		
	6	COMP15K Y OFFSET		
	7	COMP15K Cb OFFSET		
	8	COMP15K Cr OFFSET		
6	1	COMP33K ADJ(INPUT1)	Component 33K picture level adjustment (main)	
	2	COMP33K ADJ(INPUT2)		
	3	COMP33K Y A_GAIN		
	4	COMP33K Cb A_GAIN		
	5	COMP33K Cr A_GAIN		
	6	COMP33K Y OFFSET		
	7	COMP33K Cb OFFSET		
	8	COMP33K Cr OFFSET		

Page	Line	Item	Description	Remarks (adjustment detail, etc.)
7	1	ANALOG RGB ADJ	Analog RGB picture level adjustment	
	2	R A_GAIN		
	3	G A_GAIN		
	4	B A_GAIN		
	5	R OFFSET		
	6	G OFFSET		
	7	B OFFSET		
8	1	VCOM ADJ	VCOM adjustment value	
9	1	DDR2 CHECK		
	2	BA[1:0]		
	3	ADDR[13:0]		
	4	DQ[15:0]		
	5	FRC ON/OFF		
10	1	LEV1	Standard value 1	Adjustment gradation setting.
	2	LEV2	Standard value 2	
	3	LEV3	Standard value 3	
	4	LEV4	Standard value 4	
	5	LEV5	Standard value 5	
	6	LEV6	Standard value 6	
11	1	MG1R	WB adjustment Point 1, R adjustment value	Parameter for six-point adjustment
	2	MG1G	WB adjustment Point 1, G adjustment value	
	3	MG1B	WB adjustment Point 1, B adjustment value	
	4	MG2R	WB adjustment Point 2, R adjustment value	
	5	MG2G	WB adjustment Point 2, G adjustment value	
	6	MG2B	WB adjustment Point 2, B adjustment value	
	7	MG3R	WB adjustment Point 3, R adjustment value	
	8	MG3G	WB adjustment Point 3, G adjustment value	
	9	MG3B	WB adjustment Point 3, B adjustment value	
12	1	MG4R	WB adjustment Point 4, R adjustment value	Parameter for six-point adjustment
	2	MG4G	WB adjustment Point 4, G adjustment value	
	3	MG4B	WB adjustment Point 4, B adjustment value	
	4	MG5R	WB adjustment Point 5, R adjustment value	
	5	MG5G	WB adjustment Point 5, G adjustment value	
	6	MG5B	WB adjustment Point 5, B adjustment value	
	7	MG6R	WB adjustment Point 6, R adjustment value	
	8	MG6G	WB adjustment Point 6, G adjustment value	
	9	MG6B	WB adjustment Point 6, B adjustment value	
13	1	MODE SELECT		
	2	POS SELECT		
	3	POS MIN		
	4	POS MID1		
	5	POS MID2		
	6	POS MID3		
	7	POS MID4		
	8	POS MID5		
	9	POS MID6		
	10	POS MAX		
14	1	CD MIN		
	2	CD MID1		
	3	CD MID2		
	4	CD MID3		
	5	CD MID4		
	6	CD MID5		
	7	CD MID6		
	8	CD MAX		
15	1	CALC		
	2	RESET		
	3	VAL1		
	4	VAL2		
	5	VAL3		
	6	VAL4		
	7	VAL5		
	8	VAL6		

Page	Line	Item	Description	Remarks (adjustment detail, etc.)
16	1	Audio Switch		
	2	Flat Mode		
	3	EEP STATUS INIT		
	4	Input Trim DTV		
	5	Input Trim ATV		
	6	Input Trim Digital		
	7	Input Trim Analog		
	8	ATT1 Gain		
	9	ATT2 Gain		
	10	ATT3 Gain		
17	1	Auto Volume Threshold		
	2	Auto Volume Ratio		
	3	MBE Base Gain		
	4	MBE Output Gain		
	5	MBE BPF		
	6	MBE Force otct Mode		
	7	MBE Bass G Limit		
	8	HPF FC		
18	1	MVS Width		
	2	MVS Xtalk		
	3	MVS Clarity		
	4	MVS LR Gain		
	5	MVS Outout Gain		
	6	MVS Bass Gain		
	7	MVS FO		
19	1	Bass CENTER ATT		
	2	Bass Vol0 MAX		
	3	Bass Vol60 MAX		
	4	Bass Vol60 CENTER		
	5	Bass Vol0 MIN		
	6	Bass Vol60 MIN		
	7	Treble CENTER ATT		
	8	Treble Vol0 MAX		
	9	Treble Vol60 MAX		
	10	Treble Vol60 CENTER		
	11	Treble Vol0 MIN		
	12	Treble Vol60 MIN		
20	1	PEQ0 F0		
	2	PEQ0 Q		
	3	PEQ0 Gain		
	4	PEQ0 G Limit		
	5	PEQ1 F0		
	6	PEQ1 Q		
	7	PEQ1 Gain		
	8	PEQ1 G Limit		
	9	PEQ2 F0		
	10	PEQ2 Q		
	11	PEQ2 Gain		
	12	PEQ2 G Limit		
21	1	PEQ3 F0		
	2	PEQ3 Q		
	3	PEQ3 Gain		
	4	PEQ3 G Limit		
	5	PEQ4 F0		
	6	PEQ4 Q		
	7	PEQ4 Gain		
	8	PEQ4 G Limit		
	9	PEQ5 F0		
	10	PEQ5 Q		
	11	PEQ5 Gain		
	12	PEQ5 G Limit		

Page	Line	Item	Description	Remarks (adjustment detail, etc.)
22	1	PEQ6 F0		
	2	PEQ6 Q		
	3	PEQ6 Gain		
	4	PEQ6 G Limit		
	5	PEQ7 F0		
	6	PEQ7 Q		
	7	PEQ7 Gain		
	8	PEQ7 G Limit		
	9	PEQ8 F0		
	10	PEQ8 Q		
	11	PEQ8 Gain		
	12	PEQ8 G Limit		
23	1	AVC_L Fc		
	2	AVC_L Target Level		
	3	AVC_L Max Gain UP		
	4	AVC_L Attack Rate		
	5	AVC_L Release Rate		
	6	AVC_H Target Level		
	7	AVC_H Max Gain UP		
	8	AVC_H Attack Rate		
	9	AVC_H Release Rate		
24	1	Sub Vol. SP		
	2	Sub Vol. MON		
	3	Sub Vol. HP		
	4	Sub Vol. SW		
	5	Sub Vol. OPT		
	6	Clip Level SP		
	7	Clip Level MON		
	8	Clip Level HP		
	9	Clip Level SW		
	10	Clip Level OPT		
25	1	PANNEL SELECT		
	2	PWM		
	3	PWM FREQ		
	4	PWM DUTY		
	5	OSC FREQ		
	6	OSC DUTY		
26	1	BRIGHTNESS DA0		
	2	BRIGHTNESS DA1		
	3	BRIGHTNESS DA2		
	4	BRIGHTNESS DA3		
	5	BRIGHTNESS DA4		
	6	BRIGHTNESS DA5		
	7	BRIGHTNESS DA6		
	8	BRIGHTNESS DA7		
	9	BRIGHTNESS DA8		
	10	BRIGHTNESS DA9		
	11	BRIGHTNESS DA10		
	12	BRIGHTNESS DA11		
27	1	BRIGHTNESS DA12		
	2	BRIGHTNESS DA13		
	3	BRIGHTNESS DA14		
	4	BRIGHTNESS DA15		
	5	BRIGHTNESS DA16		
	6	BRIGHTNESS DA17		
	7	BRIGHTNESS DA18		
	8	BRIGHTNESS DA19		
	9	BRIGHTNESS DA20		
	10	BRIGHTNESS DA21		
	11	BRIGHTNESS DA22		

Page	Line	Item	Description	Remarks (adjustment detail, etc.)
28	1	BRIGHTNESS DA23		
	2	BRIGHTNESS DA24		
	3	BRIGHTNESS DA25		
	4	BRIGHTNESS DA26		
	5	BRIGHTNESS DA27		
	6	BRIGHTNESS DA28		
	7	BRIGHTNESS DA29		
	8	BRIGHTNESS DA30		
	9	BRIGHTNESS DA31		
	10	BRIGHTNESS DA32		
29	1	OPC33 ADLEVEL 0		
	2	OPC33 ADLEVEL 1		
	3	OPC33 ADLEVEL 2		
	4	OPC33 ADLEVEL 3		
	5	OPC33 ADLEVEL 4		
	6	OPC33 ADLEVEL 5		
	7	OPC33 ADLEVEL 6		
	8	OPC33 ADLEVEL 7		
	9	OPC33 ADLEVEL 8		
	10	OPC33 ADLEVEL 9		
	11	OPC33 ADLEVEL 10		
	12	OPC33 ADLEVEL 11		
30	1	OPC33 ADLEVEL 12		
	2	OPC33 ADLEVEL 13		
	3	OPC33 ADLEVEL 14		
	4	OPC33 ADLEVEL 15		
	5	OPC33 ADLEVEL 16		
	6	OPC33 ADLEVEL 17		
	7	OPC33 ADLEVEL 18		
	8	OPC33 ADLEVEL 19		
	9	OPC33 ADLEVEL 20		
	10	OPC33 ADLEVEL 21		
	11	OPC33 ADLEVEL 22		
31	1	OPC33 ADLEVEL 23		
	2	OPC33 ADLEVEL 24		
	3	OPC33 ADLEVEL 25		
	4	OPC33 ADLEVEL 26		
	5	OPC33 ADLEVEL 27		
	6	OPC33 ADLEVEL 28		
	7	OPC33 ADLEVEL 29		
	8	OPC33 ADLEVEL 30		
	9	OPC33 ADLEVEL 31		
32	1	V6 OS THERMO 1		
	2	V6 OS THERMO 2		
	3	V6 OS THERMO 3		
	4	V6 OS THERMO 4		
	5	V6 OS THERMO 5		
	6	V6 OS THERMO 6		
	7	V6 OS THERMO 7		
33	1	V5 OS THERMO 1		
	2	V5 OS THERMO 2		
	3	V5 OS THERMO 3		
	4	V5 OS THERMO 4		
	5	V5 OS THERMO 5		
	6	V5 OS THERMO 6		
	7	V5 OS THERMO 7		
34	1	BL TEMP1		
	2	BL TEMP2		
	3	BL TDUTY		
35	1	MONITOR TIME OUT		
	2	MONITOR MAX TEMP		
	3	MONITOR ERROR CAUSE RESET		

Page	Line	Item	Description	Remarks (adjustment detail, etc.)
36	1	LCD TEST PATTERN		
	2	LCD AGI TEST PATTERN		
	3	LCD EVA TEST PATTERN		
	4	YEL TEST PATTERN		
	5	TV TEST PATTERN 1		
	6	TV TEST PATTERN 2		
37	1	REGISTER ADDRESS LOWER		
	2	READ/WRITE		
	3	SLAVE ADDRESS		
	4	REGISTER ADDRESS UPPER		
	5	WRITE DATA UPPER		
	6	WRITE DATA LOWER		
	7	READ DATA UPPER		
	8	READ DATA LOWER		
38	1	KEY LOCK(1217)		
	2	KOUTEI AREA ALL CLEAR		
	3	A MODE AREA CLEAR		
	4	BACKUP AREA CLEAR		
	5	B MODE AREA CLEAR		
	6	EXECUTION		
39	1	ERROR STANDBY CAUSE1		
	2	ERROR STANDBY CAUSE2		
	3	ERROR STANDBY CAUSE3		
	4	ERROR STANDBY CAUSE4		
	5	ERROR STANDBY CAUSE5		
	6	ERROR STANDBY CAUSE RESET		
40	1	EEP SAVE	Writing setting values to EEPROM	
	2	EEP RECOVER	Reading setting values from EEPROM	
	3	MODL NAME		
	4	PANEL SIZE		
	5	SETTING FOR ADJ		
	6	PANEL LIMIT		
	7	PANEL RANGE LIMIT		
	8	SHORT CHECK MODE		
	9	SHORT CHECK CURRENT		
	10	CURRENT SW	Must be Low. Don't change	

## \*1 Details of P1.9 (NORMAL STANDBY CAUSE)

- |   |                            |                                      |
|---|----------------------------|--------------------------------------|
| 2 | No operation off           | in the cause of "no operation off"   |
| 3 | No signal off              | in the cause of "no signal off"      |
| 4 | PC power management mode 1 | in the cause of "Standby mode MODE1" |
| 5 | PC power management mode 2 | in the cause of "Standby mode MODE2" |
| 6 | Off timer                  | in the cause of "SLEEP timer"        |
| 8 | Command from RS232C        | in the cause of command by RS-232C   |

**\*2 Details of P1.10 (ERROR STANDBY CAUSE)**

11	Prolonged unspecified-signal input in PC mode	in the cause of continuous “out of range”, PC input mode
17	Temperature error	in the cause of abnormal temperature
1A	Monitor trouble detected	in the cause of abnormal monitor mode
22	LCD controller Rom error	in the cause of software abnormality of LCD controller

**6. Special features**

\* STANDBY CAUSE (Page 1/40)

Display of a cause (code) of the last standby

The cause of the last standby is recorded in EEPROM whenever possible.

Checking this code will be useful in finding a problem when you repair the troubled set.

\* EEP SAVE (Page 40/40)

Storage of EEP adjustment value

\* EEP RECOVER (Page 40/40)

Retrieval of EEP adjustment value from storage area

**7. Microcomputer software writing**

**7.1. Main microcomputer/monitor microcomputer software writing (Main PWB: QPWBXF282WJZZ)**

	Adjustment item	Adjustment conditions	Adjustment procedure
1	Software writing Main/Monitor microcomputer software	Checker process  File version check USB memory check	<ol style="list-style-type: none"> <li>1. Connect the given jig to SC9301 (TL9301-TL9309, TL9311-TL9316) using the checker.</li> <li>2. Connect the USB memory to J8001 (TL8003-8006) using the checker.</li> <li>3. Apply the specified voltage to the main PWB and perform boot from the jig.</li> <li>4. Send the software writing start command using RS232C.</li> <li>5. Send the writing status check command and confirm the response of OK. Then turn off the power.</li> </ol> <p>CAUTION: When the USB memory is not inserted or reading error occurs, nothing is written.</p>

**7.2. Model/inch discrimination writing (Main PWB: QPWBXF282WJZZ)**

- When writing the sub microcomputer software, the model data is configured with the software from the USB memory mounted to the checker.
- Reference and setting change are enabled through the process menu (Page 40/40) and RS-232C communication.

**8. Signal adjustment**

**8.1. LCD section adjustment 1 [LCD module adjustment]**

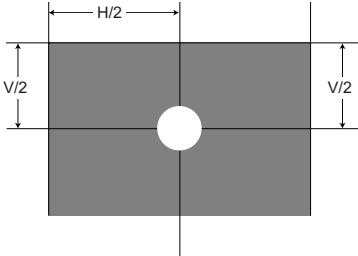
	Adjustment item	Adjustment conditions	Adjustment procedure
1	Opposite bias adjustment. Left/Right (LCD module adjustment item)	Adjustment in the center position of the panel	<ol style="list-style-type: none"> <li>1. Enter the process mode using the process adjustment remote control.</li> <li>2. Select [VCOM ADJ] using the Channel ↑, ↓ keys on the remote control.</li> <li>3. Press the Enter key to check that the pattern for adjustment is displayed.</li> <li>4. Make adjustment so that the flicker located in the center of the screen is minimized using the Volume +/- keys on the remote control.</li> <li>5. If the status is optimized in step 4, press the Enter key to turn off the pattern.</li> </ol> <p>CAUTION: * Make adjustment without ANT signal (since the active backlight changes the brightness).</p> <p>[Adjustment position]</p> 

**8.2. LCD section adjustment 2 [LCD module adjustment] (LC-65E77UM/LC-C6577UM Only)**

	Adjustment item	Adjustment conditions	Adjustment procedure
1	Vertical luminance difference adjustment (LCD module adjustment item)	Visual check Adjustment in the middle of the panel	1. Enter the process mode using the process adjustment remote control. 2. Select [LCD LUMA ADJ] using the Channel $\uparrow/\downarrow$ keys on the remote control. 3. Press the Enter key to check that the pattern for adjustment is displayed. 4. Make adjustment so that the vertical luminance difference in the middle of the screen is minimized using the Volume +/- keys on the remote control. 5. If the status is optimized in step 4, press the Enter key to turn off the pattern. [Criterion] No difference must be observable when visually checked.  CAUTION: The adjustment sequence is as follows: Common Adjustment $\rightarrow$ Aging $\rightarrow$ Common adjustment $\rightarrow$ W/B adjustment (top) $\rightarrow$ Vertical luminance difference adjustment (bottom).

**8.3. Video Signal adjustment Procedure**

**8.3.1 Signal check**

■ Before adjustment, check that the adjustment jig and signal source are set for Sharp LCD US.

■ Signal generator level adjustment check (Adjust to the standard value level.)

- Composite signal: 0.714Vp-p  $\pm$  0.02Vp-p (Pedestal to white level)
- 15K component signal: Y level: 0.714Vp-p  $\pm$  0.02Vp-p (Pedestal to white level)  
PB/PR level: 0.7Vp-p  $\pm$  0.02Vp-p
- 33K component signal: Y level: 0.7Vp-p  $\pm$  0.02Vp-p (Pedestal to white level)  
PB/PR level: 0.7Vp-p  $\pm$  0.02Vp-p
- Analog RGB: RGB level: 0.7Vp-p  $\pm$  0.02Vp-p (Pedestal to white level)

**8.3.2 Process mode**

	Adjustment point	Adjustment conditions	Adjustment procedure
	Process mode		Enter the process adjustment mode using the process adjustment remote control.

**8.3.3 Composite N358 signal/tuner adjustment**

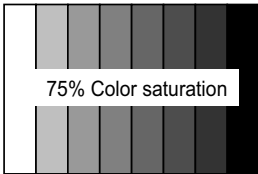
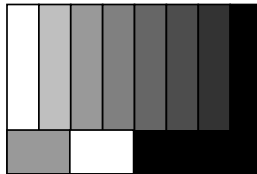
	Adjustment point	Adjustment conditions	Adjustment procedure
1	Setting	N358 signal US-10ch	•Send the N358 color bar (color saturation: 75%) signal to the Video 3 video input. •Send the in-house signal (use US-10ch) to TUNER.  <div style="display: flex; justify-content: space-around; align-items: center;"> <div style="text-align: center;"> <p><b>[Video input signal]</b></p>  <p>75% Color saturation</p> <p><math>\uparrow</math> 100% white</p> </div> <div style="text-align: center;"> <p><b>[US-10CH]</b></p>  <p><math>\uparrow</math> 100% white</p> </div> </div>
2	Automatic adjustment execution		Point the cursor to [■N358 ALL ADJ(INPUT3)] and press the [Enter] key. The adjustment is complete when [■N358 ALL ADJ(INPUT3) OK] is displayed.

**8.3.4 Component 15K signal adjustment**

	Adjustment point	Adjustment conditions	Adjustment procedure
1	Setting	480i signal	•Send the 100% color bar signal to the Video 1 component input.  <div style="text-align: center;">  <p>100% Color saturation</p> <p>480i 100% color bar</p> <p><math>\uparrow</math> 100% white      <math>\uparrow</math> 0% black</p> </div>
2	Automatic adjustment execution		Point the cursor to [■COMP15K ADJ(INPUT1)] and press the [Enter] key. The adjustment is complete when [■COMP15K ADJ(INPUT1) OK] is displayed.

**8.3.5 Component 33K signal adjustment**

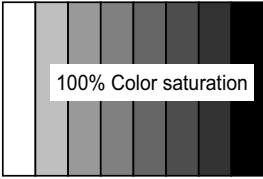
	Adjustment point	Adjustment conditions	Adjustment procedure
1	Setting	1080i signal	<p>•Send the 100% color bar signal to the Video 1 component input.</p>  <p>1080i 100% color bar</p> <p>↑ 100% white      ↑ 0% black</p>
2	Automatic adjustment execution		<p>Point the cursor to [■COMP33K ADJ(INPUT1)] and press the [Enter] key. The adjustment is complete when [■COMP33K ADJ(INPUT1) OK] is displayed.</p>

**8.3.6 Analog RGB signal adjustment**

	Adjustment point	Adjustment conditions	Adjustment procedure
1	Setting	Analog RGB Signal: XGA	<p>•Send the 100% color bar signal to the Video 4 analog RGB input.</p>  <p>XGA (1024x768) 100% color bar</p> <p>↑ 100% white      ↑ 0% black</p>
2	Automatic adjustment execution		<p>Point the cursor to [■ANALOG RGB ADJ] and press the [Enter] key. The adjustment is complete when [■ANALOG RGB ADJ OK] is displayed.</p>

**8.3.7 Tuner/V-CHIP adjustment**

	Adjustment point	Adjustment conditions	Adjustment procedure
1	Setting	NTSC RF signal US-7(AIR)ch	<p>•Send the NTSC signal to the RF antenna input.</p> 
2	Automatic adjustment execution		<p>Point the cursor to [■TUNER VCHIP TEST(*07ch)] and press the [Enter] key. (* Adjust the selected channel to the in-house signal.) The adjustment is OK when [■A-OK(**.*)/VM-OK] is displayed in Blue. (NG when A-NG/VM-NG is displayed in Yellow or red.) It is OK when the deviation from the center frequency is <math>\pm 0.0625\text{MHz}</math> or less.</p>

## 9. White balance adjustment

## 9.1. White balance adjustment (for LC-60E77UN/LC-C6077UN)

	Adjustment point	Adjustment conditions	Adjustment procedure																																														
1	Setting		<p>(For details about the adjustment procedure, refer to “Kameyama Model Integrated Monitor WB Adjustment Specification V1.4”.)</p> <p>1) Set the set to the following conditions.            AV MODE: [DYNAMIC]            Backlight: +16            Active Contrast: OFF            Aging Time: Min. 60 minutes</p> <p>2) Connect the set with the white balance adjustment jig.</p>																																														
2	Automatic adjustment execution	<p>[Command]            Process mode            KRSW0001            KKT10037</p> <p>Setting            KYOF0000            OSDS0001            SBSL0016</p> <p>Multi-point adjustment mode            MSET0001</p> <p>Point 6            WBI60928            MG6G****            MG6B****            MG6R****</p> <p>Point 5            WBI50808            MG5G****            MG5B****            MG5R****</p> <p>Point 4            WBI40696            MG4G****            MG4B****            MG4R****</p> <p>Point 3            WBI30480            MG3G****            MG3B****            MG3R****</p> <p>Point 2            WBI20236            MG2G****            MG2B****            MG2R****</p> <p>Point 1            WBI10184            MG1G****            MG1B****            MG1R****</p> <p>Writing            MSET0003</p>	<p>[Adjustment procedure]</p> <p>1) Transmit the “Monitor adjustment process” code using the remote control.</p> <p>2) Set the point 6 to the specified gradation, specify the strongest color as the fixed color, and adjust the RGB so that it becomes the standard value through negative adjustment.</p> <p>3) Set the point 5 to the specified gradation, set the G correction value (3232 x G value of point 6/3712) (fractions rounded off), and adjust the RB so that it becomes the standard value.</p> <p>4) Set the point 4 to the specified gradation, set the G correction value (2784 x G value of point 6/3712) (fractions rounded off), and adjust the RB so that it becomes the standard value.</p> <p>5) Set the point 3 to the specified gradation, set the G correction value (1920 x G value of point 6/3712) (fractions rounded off), and adjust the RB so that it becomes the standard value.</p> <p>6) Set the point 2 to the specified gradation, set the G correction value (944 x G value of point 6/3712) (fractions rounded off), and adjust the RB pattern so that it becomes the standard value.</p> <p>7) Set the point 1 to the specified gradation, set the G correction value (736 x G value of point 6/3712) (fractions rounded off), and adjust the RB so that it becomes the standard value.</p> <p>8) Write the adjustment value by the MSET0003 command and turn off the AC power.</p> <p>* RGB initial value of point 6: Set gradation 3712            * RGB initial value of points 1 to 5: G correction value of each point</p> <p>[Adjustment value]            * According to the “Standard settings” submitted by the Technical Department</p> <p>[Adjustment standard value]            Measuring instrument: [Minolta CA-210] Technical measuring instrument</p> <table border="1"> <thead> <tr> <th></th> <th>Level</th> <th>Reference value</th> <th>Adjustment spec</th> <th>Inspection spec</th> </tr> </thead> <tbody> <tr> <td rowspan="2">Point 6</td> <td rowspan="2">928</td> <td>X=0.272</td> <td rowspan="2">±0.0010</td> <td rowspan="2">±0.0020</td> </tr> <tr> <td>y=0.277</td> </tr> <tr> <td rowspan="2">Point 5</td> <td rowspan="2">808</td> <td>X=0.272</td> <td rowspan="2">±0.0010</td> <td rowspan="2">±0.0020</td> </tr> <tr> <td>y=0.277</td> </tr> <tr> <td rowspan="2">Point 4</td> <td rowspan="2">696</td> <td>X=0.272</td> <td rowspan="2">±0.0015</td> <td rowspan="2">±0.0030</td> </tr> <tr> <td>y=0.277</td> </tr> <tr> <td rowspan="2">Point 3</td> <td rowspan="2">480</td> <td>X=0.272</td> <td rowspan="2">±0.0020</td> <td rowspan="2">±0.0040</td> </tr> <tr> <td>y=0.277</td> </tr> <tr> <td rowspan="2">Point 2</td> <td rowspan="2">236</td> <td>X=0.272</td> <td rowspan="2">±0.0030</td> <td rowspan="2">±0.0060</td> </tr> <tr> <td>y=0.277</td> </tr> <tr> <td rowspan="2">Point 1</td> <td rowspan="2">184</td> <td>X=0.272</td> <td rowspan="2">±0.0045</td> <td rowspan="2">±0.0090</td> </tr> <tr> <td>y=0.277</td> </tr> <tr> <td>Remarks</td> <td></td> <td colspan="3">           Setting conditions when performing inspection            AV MODE: [DYNAMIC] (Reset)            Monochro: ON            Active Contrast: OFF            Aging Time: Min. 60 minutes         </td> </tr> </tbody> </table>		Level	Reference value	Adjustment spec	Inspection spec	Point 6	928	X=0.272	±0.0010	±0.0020	y=0.277	Point 5	808	X=0.272	±0.0010	±0.0020	y=0.277	Point 4	696	X=0.272	±0.0015	±0.0030	y=0.277	Point 3	480	X=0.272	±0.0020	±0.0040	y=0.277	Point 2	236	X=0.272	±0.0030	±0.0060	y=0.277	Point 1	184	X=0.272	±0.0045	±0.0090	y=0.277	Remarks		Setting conditions when performing inspection AV MODE: [DYNAMIC] (Reset) Monochro: ON Active Contrast: OFF Aging Time: Min. 60 minutes		
	Level	Reference value	Adjustment spec	Inspection spec																																													
Point 6	928	X=0.272	±0.0010	±0.0020																																													
		y=0.277																																															
Point 5	808	X=0.272	±0.0010	±0.0020																																													
		y=0.277																																															
Point 4	696	X=0.272	±0.0015	±0.0030																																													
		y=0.277																																															
Point 3	480	X=0.272	±0.0020	±0.0040																																													
		y=0.277																																															
Point 2	236	X=0.272	±0.0030	±0.0060																																													
		y=0.277																																															
Point 1	184	X=0.272	±0.0045	±0.0090																																													
		y=0.277																																															
Remarks		Setting conditions when performing inspection AV MODE: [DYNAMIC] (Reset) Monochro: ON Active Contrast: OFF Aging Time: Min. 60 minutes																																															

9.2. White balance adjustment (for LC-65E77UM/LC-C6577UM)

	Adjustment point	Adjustment conditions	Adjustment procedure																																														
1	Setting		(For details about the adjustment procedure, refer to “Kameyama Model Integrated Monitor WB Adjustment Specification V1.4”.) 1) Set the set to the following conditions. AV MODE: [DYNAMIC] Backlight: +16 Active Contrast: OFF Aging Time: Min. 60 minutes 2) Connect the set with the white balance adjustment jig.																																														
2	Automatic adjustment execution	[Command] Process mode KRSW0001 KKT10037  Setting KYOF0000 OSDS0001 SBSL0016  Multi-point adjustment mode MSET0001  Point 6 WBI60928 MG6G**** MG6B**** MG6R****  Point 5 WBI50784 MG5G**** MG5B**** MG5R****  Point 4 WBI40580 MG4G**** MG4B**** MG4R****  Point 3 WBI30420 MG3G**** MG3B**** MG3R****  Point 2 WBI20284 MG2G**** MG2B**** MG2R****  Point 1 WBI10184 MG1G**** MG1B**** MG1R****  Writing MSET0003	[Adjustment procedure] 1) Transmit the “Monitor adjustment process” code using the remote control. 2) Set the point 6 to the specified gradation, specify the strongest color as the fixed color, and adjust the RGB so that it becomes the standard value through negative adjustment. 3) Set the point 5 to the specified gradation, set the G correction value (3136 x G value of point 6/3712) (fractions rounded off), and adjust the RB so that it becomes the standard value. 4) Set the point 4 to the specified gradation, set the G correction value (2320 x G value of point 6/3712) (fractions rounded off), and adjust the RB so that it becomes the standard value. 5) Set the point 3 to the specified gradation, set the G correction value (1680 x G value of point 6/3712) (fractions rounded off), and adjust the RB so that it becomes the standard value. 6) Set the point 2 to the specified gradation, set the G correction value (1136 x G value of point 6/3712) (fractions rounded off), and adjust the RB pattern so that it becomes the standard value. 7) Set the point 1 to the specified gradation, set the G correction value (736 x G value of point 6/3712) (fractions rounded off), and adjust the RB so that it becomes the standard value. 8) Write the adjustment value by the MSET0003 command and turn off the AC power. * RGB initial value of point 6: Set gradation 3712 * RGB initial value of points 1 to 5: G correction value of each point [Adjustment value] * According to the “Standard settings” submitted by the Technical Department [Adjustment standard value] Measuring instrument: [Minolta CA-210] Technical measuring instrument  <table border="1" data-bbox="673 1170 1502 1553"> <thead> <tr> <th></th> <th>Level</th> <th>Reference value</th> <th>Adjustment spec</th> <th>Inspection spec</th> </tr> </thead> <tbody> <tr> <td rowspan="2">Point 6</td> <td rowspan="2">928</td> <td>X=0.272</td> <td rowspan="2">±0.0010</td> <td rowspan="2">±0.0020</td> </tr> <tr> <td>y=0.277</td> </tr> <tr> <td rowspan="2">Point 5</td> <td rowspan="2">784</td> <td>X=0.272</td> <td rowspan="2">±0.0010</td> <td rowspan="2">±0.0020</td> </tr> <tr> <td>y=0.277</td> </tr> <tr> <td rowspan="2">Point 4</td> <td rowspan="2">580</td> <td>X=0.272</td> <td rowspan="2">±0.0015</td> <td rowspan="2">±0.0030</td> </tr> <tr> <td>y=0.277</td> </tr> <tr> <td rowspan="2">Point 3</td> <td rowspan="2">420</td> <td>X=0.272</td> <td rowspan="2">±0.0020</td> <td rowspan="2">±0.0040</td> </tr> <tr> <td>y=0.277</td> </tr> <tr> <td rowspan="2">Point 2</td> <td rowspan="2">284</td> <td>X=0.272</td> <td rowspan="2">±0.0030</td> <td rowspan="2">±0.0060</td> </tr> <tr> <td>y=0.277</td> </tr> <tr> <td rowspan="2">Point 1</td> <td rowspan="2">184</td> <td>X=0.272</td> <td rowspan="2">±0.0040</td> <td rowspan="2">±0.0080</td> </tr> <tr> <td>y=0.277</td> </tr> <tr> <td>Remarks</td> <td></td> <td colspan="3">Setting conditions when performing inspection                      AV MODE: [DYNAMIC] (Reset)                      Monochro: ON                      Active Contrast: OFF                      Aging Time: Min. 60 minutes</td> </tr> </tbody> </table>		Level	Reference value	Adjustment spec	Inspection spec	Point 6	928	X=0.272	±0.0010	±0.0020	y=0.277	Point 5	784	X=0.272	±0.0010	±0.0020	y=0.277	Point 4	580	X=0.272	±0.0015	±0.0030	y=0.277	Point 3	420	X=0.272	±0.0020	±0.0040	y=0.277	Point 2	284	X=0.272	±0.0030	±0.0060	y=0.277	Point 1	184	X=0.272	±0.0040	±0.0080	y=0.277	Remarks		Setting conditions when performing inspection AV MODE: [DYNAMIC] (Reset) Monochro: ON Active Contrast: OFF Aging Time: Min. 60 minutes		
	Level	Reference value	Adjustment spec	Inspection spec																																													
Point 6	928	X=0.272	±0.0010	±0.0020																																													
		y=0.277																																															
Point 5	784	X=0.272	±0.0010	±0.0020																																													
		y=0.277																																															
Point 4	580	X=0.272	±0.0015	±0.0030																																													
		y=0.277																																															
Point 3	420	X=0.272	±0.0020	±0.0040																																													
		y=0.277																																															
Point 2	284	X=0.272	±0.0030	±0.0060																																													
		y=0.277																																															
Point 1	184	X=0.272	±0.0040	±0.0080																																													
		y=0.277																																															
Remarks		Setting conditions when performing inspection AV MODE: [DYNAMIC] (Reset) Monochro: ON Active Contrast: OFF Aging Time: Min. 60 minutes																																															

**10. Key writing****10.1. EDID writing (Main PWB: QPWBXF282WJZZ HDMI • RBG Input Terminal)**

	<b>Adjustment point</b>	<b>Adjustment conditions</b>	<b>Adjustment procedure</b>
1	HDMI EDID writing (Main PWB)	Inspection mode File version check	1) Enter the process mode. 2) Point the cursor to [EDID WRITE ENT] and press the [ENT] key. The writing is complete when [ENT WRITE OK] is displayed. (If not written, HDMI does not function.)  <b>CAUTION:</b> Perform the data writing after setting the model discrimination. The data based on the model discrimination information is recorded in EEPROM.
2	Analog RGB EDID writing (Main PWB)	Inspection mode File version check	1) Write the EDID data for analog RGB into IC1809 mounted on the main PWB. TL1821 ••• I2C clock, TL1823 ••• I2C data TL1824 ••• 5V, TL1822 ••• GND TL1848 ••• Write protection (H: WP, L: write enable) 2) Perform the data writing before making inspection using the checker.

**10.2. MAC address writing (Main PWB: QPWBXF282WJZZ)**

1. Write the MAC key data into IC8453 mounted on the MAIN PWB via RS232C.
2. The data must be written before making the inspection using the checker.

### 11. Factory setting

After completing the factory setting, pull out the AC cord to complete the setting.

CAUTION: Do not turn on the power after completing the factory setting. If the power is turned on, configure the factory setting again.

	Adjustment point	Adjustment conditions	Adjustment procedure
1	Factory setting	Complete the setting by pulling out the AC cord.	<ul style="list-style-type: none"> <li>•Point the cursor to [INDUSTRY INIT (+Cause)], set to "ON" using [+] / [-] of the [VOL] key, and press the [ENT] key.</li> <li>The version confirmation screen appears on the green screen. It is completed when [SUCCESS] is displayed at the top.</li> <li>(If error occurs, [ERROR] is displayed on the red screen.)</li> <li>•Turn off the AC power.</li> </ul> <p>The following items are initialized when configuring the factory setting.</p> <ol style="list-style-type: none"> <li>1) User setting values</li> <li>2) Channel data (broadcasting frequency, etc.)</li> <li>3) Password setting value</li> <li>4) Operating time</li> <li>5) Standby Cause (Monitor, Main)</li> <li>6) Auto installation flag</li> <li>7) V-CHIP block setting value</li> </ol>

### 12. Writing the inch and model name onto EEPROM

Writing method

1. Pull out the AC cord.
2. Copy the application for writing inch/model name (HLNRMA01.USB) and model/inch file (60E77.MDL) to the USB memory.
3. Hold down the power button and insert the AC cord.
4. Release the power button after 5 seconds.
5. Update starts.

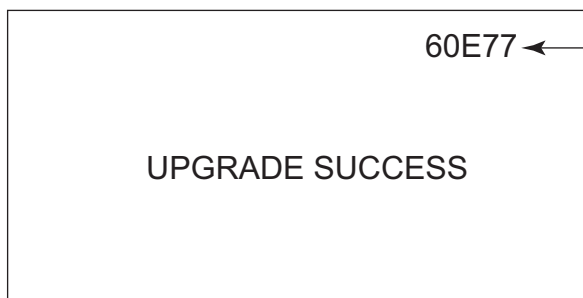

The inch and model name are displayed.

6. Pull out the AC cord.

Model/inch file

- 60E77.MDL
- 65E77.MDL
- C6077.MDL
- C6577.MDL

NOTE: When replacing the main PWB, make sure to perform the writing the inch and model name onto EEPROM

## [2] PUBLIC MODE SETTING PROCEDURE

### 1. How to start Public Mode

- There are the following two ways to get the public mode setup screen displayed.

- ① In the adjustment process mode, turn on "PUBLIC MODE". Also press the "CH (  $\wedge$  )" and "VOL (+)" keys on the set at once and turn on the power.
- ② 1) Press the "INPUT" and "VOL (+)" keys on the set at once and turn on the power.  
2) Get the password input screen displayed.

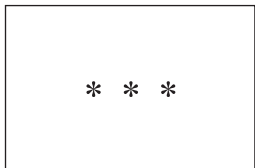
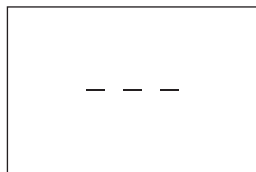

#### Procedure

- The input starts with the leftmost digit.
- Use the numeric keys [1] thru [9] and [0] keys on the remote controller. The other keys are not acceptable.
- With a numeric-key input, "-" will change to "\*". The input position will move one digit to the right.
- With all the 3 digits entered, the password will be verified.

- 3) The 3-digit password is now verified.

The password [0] [2] [7] provides for the public mode screen. (This screen comes on with whatever adjustment process settings.)

With any other passwords, the screen changes to the normal mode.

### 2. How to exit Public Mode

There are the following ways to quit the public mode setup screen.

- Turn off "PUBLIC MODE" in the adjustment process mode. (☆) ← This way alone is not for quitting the setup screen, but for quitting the mode itself.
- Turn off the power with the "POWER" key. (★)
- Select "EXECUTE". (★)
- ★ ... "PUBLIC MODE" stays on in the adjustment process mode.
- ☆ ... The settings will be back to the factory ones.

### 3. Public Mode Setting Values

- With the factory settings made, the public mode settings get initialized. (The adjustment process remains intact.)

#### 4. Public Mode Menu

The guidance is not displayed on screen.

Setup procedure

- To move the cursor up and down, use the "cursor UP/DOWN" key (remote controller) and "CH ( ^ )/( v )" key (remote controller and set).
- To change the settings, use the "cursor RIGHT/LEFT" key (remote controller) and "VOL (+)/(-)" key (remote controller and set).
- To save new settings, keep the cursor at "EXECUTE" and use "ENTER" key (remote controller and set).

PUBLIC MODE	
POWER ON FIXED	[VARIABLE ]
MAXIMUM VOLUME	[ 60 ]
VOLUME FIXED	[VARIABLE ]
VOLUME FIXED LEVEL	[ 20 ]
RC BUTTON	[RESPOND ]
PANEL BUTTON	[RESPOND ]
MENU BUTTON	[RESPOND ]
AV POSITION FIXED	[VARIABLE ]
ON SCREEN DISPLAY	[YES ]
INPUT MODE START	[NORMAL ]
INPUT MODE FIXED	[VARIABLE ]
LOUD SPEAKER	[ON ]
RC_PATH_THROUGH	[OFF ]
232C POWON	[DISABLE ]
PUBLIC MODE	[OFF ]
RESET	
EXECUTE	

## 5. On Setting Items

\* "EZ-SETUP" discussed below indicates "EZ-SETUP" after the first power-on".

### 1) POWER ON FIXED

Selection	Selection between "Variable" and "Fixed" (loop provided)
Default	– (Variable)
Explanation	In "Fixed" setting, the power-off by the power key of the unit is invalidated and the image is kept being received. The power can be turned off by stopping the power supply from AC.
Limit in Setting	Refer to the "Power-On Fixed" sheet.
Exception	None
Remarks	• In "Variable" setting, the power operation is in wait for 1 sec. and then turned off when the main power switch is off.

### 2) MAXIMUM VOLUME

Selection	Adjustment from 0 to 60 (no loop)
Default	60
Explanation	Sound volume can not be adjusted higher than the preset value.
Limit in Setting	<ul style="list-style-type: none"> <li>• When the sound volume is set lower than 59, only figures are displayed and the sound volume bar is not displayed.</li> <li>• The maximum sound volume for ON-timer (Wake up timer) is limited also to the preset value.</li> </ul>
Exception	
Remarks	• When the sound volume is set higher than the MAX setting by the adjusting process, the sound volume control operation is prohibited for turn-up and the sound volume should be turned down to MAX in this state.

### 3) VOLUME FIXED

Selection	Selection between "Variable", "Fixed", "ACON (AC CTRL)" and "AC/RCON (AC/RC CTRL)" (loop provided)
Default	Variable
Explanation	<ul style="list-style-type: none"> <li>• FIXED: Fixed at the level adjusted for a fixed volume.</li> <li>• AC CTRL: Start-up at the level specified for a fixed volume at ACON.</li> <li>• AC/RC CTRL: Start-up at the level specified for a fixed volume at start.</li> </ul>
Limit in Setting	<ul style="list-style-type: none"> <li>• The sound volume for the ON-timer (Wake up timer) is fixed also without display of menu. Besides, the setting is made impossible. (Basically, the menu is not displayed.)</li> <li>• The following keys become invalid: <ul style="list-style-type: none"> <li>• Sound volume Up/Down (VOL +/-) [for both remote control and the unit]</li> <li>• Mute (MUTE)</li> </ul> </li> </ul>
Exception	• In the item "VOLUME" of adjustment process, the sound volume can be set freely irrespective of this setting.
Remarks	<ul style="list-style-type: none"> <li>• As for sound volume fixing and sound volume MAX level, the sound volume fixing has priority.</li> <li>• Once the sound volume has been changed by adjustment process, it should be set back to the sound volume preset by sound volume fixing level when the adjustment process ends.</li> </ul>

### 4) VOLUME FIXED LEVEL

Selection	Adjustment from 1 to 60 (no loop)
Default	20
Explanation	The sound volume to be fixed by "Volume fixed" is determined.
Limit in Setting	None
Exception	None
Remarks	Setting is valid only when "Volume fixed" is selected for "fixed".

### 5) RC BUTTON

Selection	Selection between "Respond", "No Respond" and "Limited" (loop provided)
Default	Respond
Explanation	<p>Making the remote controller settings.</p> <ul style="list-style-type: none"> <li>• At the "No Respond" setting, the remote controller keys are disabled. Its power key (reception/standby key) is disabled too.</li> <li>• At the "Limited" setting, some channel-related keys alone are operative. All the other remote controller keys (power, volume ▲/▼, channel ▲/▼, light control (brightness sensor), broadcast select) are inoperative.</li> </ul>
Limit in Setting	① In "No respond" setting, all the keys (including the power key) are not accepted.
Exception	<ul style="list-style-type: none"> <li>• Adjustment process, inspection process and hotel only keys are valid irrespective of setting.</li> <li>• All the keys can be used in adjustment process, inspection mode and hotel menu irrespective of setting.</li> </ul>
Remarks	

## 6) PANEL BUTTON

Selection	Selection between "Respond" and "No respond" (loop provided)
Default	Respond
Explanation	All the operations by keys (except the power key) of the unit can be invalidated.
Limit in Setting	
Exception	<ul style="list-style-type: none"> <li>• Adjustment process, inspection mode and hotel menu mode can be started irrespective of setting.</li> <li>• All the keys can be used in adjustment process, inspection mode and hotel menu irrespective of setting.</li> </ul>
Remarks	

## 7) MENU BUTTON

Selection	Selection between "Respond" and "No respond" (loop provided)
Default	Respond
Explanation	In "No respond" setting, the menu operation by the menu key of the remote control and the menu key of the unit are invalidated.
Limit in Setting	
Exception	<ul style="list-style-type: none"> <li>• Adjustment process, inspection mode and hotel menu mode can be started irrespective of setting.</li> <li>• All the keys can be used in adjustment process, inspection mode and hotel menu irrespective of setting.</li> </ul>
Remarks	

## 8) ON SCREEN DISPLAY

Selection	Selection between "Yes", "No" (loop provided)
Default	Yes
Explanation	<ul style="list-style-type: none"> <li>• At the "No" setting, the following items are not displayed on screen: register, setting, adjustment menu, channel call and volume bar.</li> </ul> <p>On the wide-screen models, an input selection is immediately made because the menu is not displayed.</p> <ul style="list-style-type: none"> <li>• At the "Limited" setting, some items cannot be displayed on screen.</li> </ul> <p>On the Japan-destined models, the channel call "Message" alone cannot be displayed. (This is because the channel call message may be confused with a message being sent from the hotel.)</p> <p>On the North America-destined models, the OSD works the same as at the "No" setting.</p>
Limit in Setting	<ul style="list-style-type: none"> <li>• Keys falling under any of the following items become invalid.</li> </ul> <ol style="list-style-type: none"> <li>① Appearance of screen changes and the sound changes.</li> <li>② Personal functions which are hard to restore.</li> </ol> <p>Screen display, menu, OFF-timer, ON-timer, AV MODE, screen size switching, clock setting, treble emphasis, AUDIO ONLY, sound changeover, LANGUAGE, CLOSED CAPTION</p>
Others	<ul style="list-style-type: none"> <li>• Simple input switching is generated. Those which are restored soon after leaving as they are and may be requested for change by customer are not prohibited.</li> </ul> <p>Brightness sensor (BACKLIGHT) and PIC. FLIP</p>
Exception	<ul style="list-style-type: none"> <li>• Such a caution which is displayed independently is displayed as it is.</li> </ul> <p>Non-responding signal caution</p>
Remarks	<ul style="list-style-type: none"> <li>• When CC has already been ON, CLOSED CAPTION is displayed.</li> </ul>

## 9) INPUT MODE START

Selection	Selection between "Normal", "Air (✳)", "INPUT 1/2/3", "PC", "HDMI 1/2/3/4/5", "DVI" (loop provided)
Default	Normal
Explanation	In power-ON, the input source to be started or channel can be set. (In standard mode, the operation follows the last memory.)
About options	<ul style="list-style-type: none"> <li>• All the input sources in the model are made selectable.</li> <li>• In TV mode, the channel to be set follows the last memory and the content of the last memory is included in the notation by options. Ex.) Air (2), Cable (98.1) etc.</li> </ul>
Limit in Setting	<ul style="list-style-type: none"> <li>• The display of channel setting menu and the channel setting operation are prohibited.</li> </ul>
Exception	
Remarks	<ul style="list-style-type: none"> <li>• In setting at "Normal", the setting of "Input mode fixed" is changed to "Variable" and selection should be prohibited.</li> </ul>

## 10)INPUT MODE FIXED

Selection	Selection between "Variable", "Fixed", "ACON (AC CTRL)" and "AC/RCON (AC/RC CTRL)" (loop provided)
Default	– (Variable)
Explanation	<ul style="list-style-type: none"> <li>• At the "Fixed" setting, the TV set gets started with the settings of "Input mode start", and then any other channels and inputs are not accepted.</li> <li>• At the "ACON (AC CTRL)" setting, the TV set gets started with the settings of "Input mode start" under AC control.</li> <li>• At the "AC/RCON (AC/RC CTRL)" setting, the TV set gets started with the settings of "Input mode start" under either control.</li> </ul>
Limit in Setting	<ul style="list-style-type: none"> <li>• With the execution of hotel mode, the input source is forced to change to that set by "Input mode start" and the channel switching and input switching are prohibited thereafter.</li> <li>• ON-timer's (Wake-up timer) channel items are not displayed or the operation is prohibited. (Basically, they are not displayed.)</li> <li>• The following keys are invalidated. CH ▲ / ▼, direct tuning button, FLASHBACK, input</li> </ul> <p>*However, the keys (input switching and CH ▲ / ▼ keys) of the unit for menu operation remain valid.</p>
Exception	None
Remarks	<ul style="list-style-type: none"> <li>• In the following case, setting is cancelled and mode is changed to "Variable".</li> </ul> <p>① When the setting of "Input mode start" is set to "Normal".</p>

## 11)RC\_PATH\_THROUGH

Selection	Selection between "OFF", "ON: TV RCE" and "ON: TV RCD" (loop provided)
Default	OFF
Explanation	Function to feed the remote controller-received signal to Pin 9 (open) on the RS232C.
Limit in Setting	None
Exception	None
Remarks	None

## 12)AV POSITION FIXED

Selection	Selection between "Variable" and "Fixed" (loop provided)
Default	Variable
Explanation	<p>In case of "Fixed" setting,</p> <ul style="list-style-type: none"> <li>– Menu "Picture" and "Audio" setting can't be changed like "Dynamic (Fixed)".</li> <li>– When "AV Mode" key is pressed, TV just displays current AV Mode (cannot be changed.).</li> </ul>
Limit in Setting	None
Exception	None
Remarks	<ul style="list-style-type: none"> <li>• When receiving with AV Position key, OPC, Dolby key and other direct audio select keys, the current display stays on and no setting can be changed.</li> <li>• Even by initializing personal information, the hotel-mode settings are kept intact. In this way, the AV positions, video and audio adjustment settings are not initialized.</li> </ul>

## 13)LOUD SPEAKER (ON/OFF)

Selection	Selection between "ON" and "OFF" (loop provided)
Default	ON
Explanation	If "OFF" is selected, TV stops Speaker output even without Headphone connected.
Limit in Setting	None
Exception	None
Remarks	<ul style="list-style-type: none"> <li>• Press the volume UP/DOWN key, and the mute icon appears for 4 seconds.</li> <li>• The mute key and audio-related keys are displayed with caution.</li> <li>• Usually, the headphones and monitor audio outputs can be adjustable.</li> </ul>

## 14)232C POWON

Selection	Selection between "Disable" and "Enable" (loop provided)
Default	Disable
Explanation	In the standby mode, the power-on by the 232C command is enabled or disabled.
Limit in Setting	None
Exception	None
Remarks	None

LC-60E77UN/LC-65E77UM/LC-C6077UN/LC-C6577UM

15)PUBLIC MODE (ON/OFF)

Selection	Selection between "ON" and "OFF" (loop provided)
Default	OFF
Explanation	In case of "ON", public mode settings are effected.
Limit in Setting	None
Exception	None
Remarks	The public-mode settings are operable only when this item is set at ON.

# CHAPTER 6. TROUBLESHOOTING TABLE

## [1] TROUBLESHOOTING TABLE

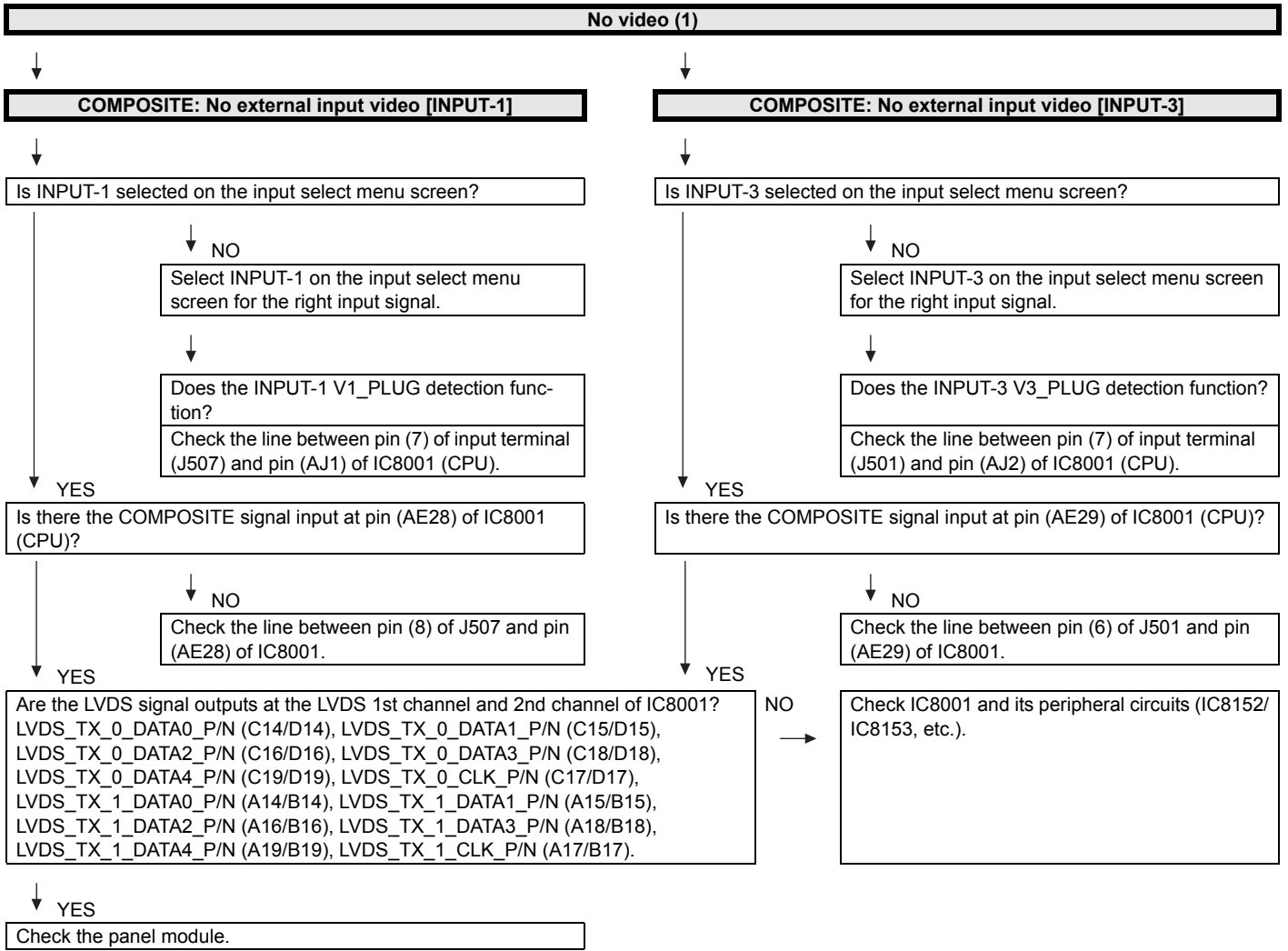

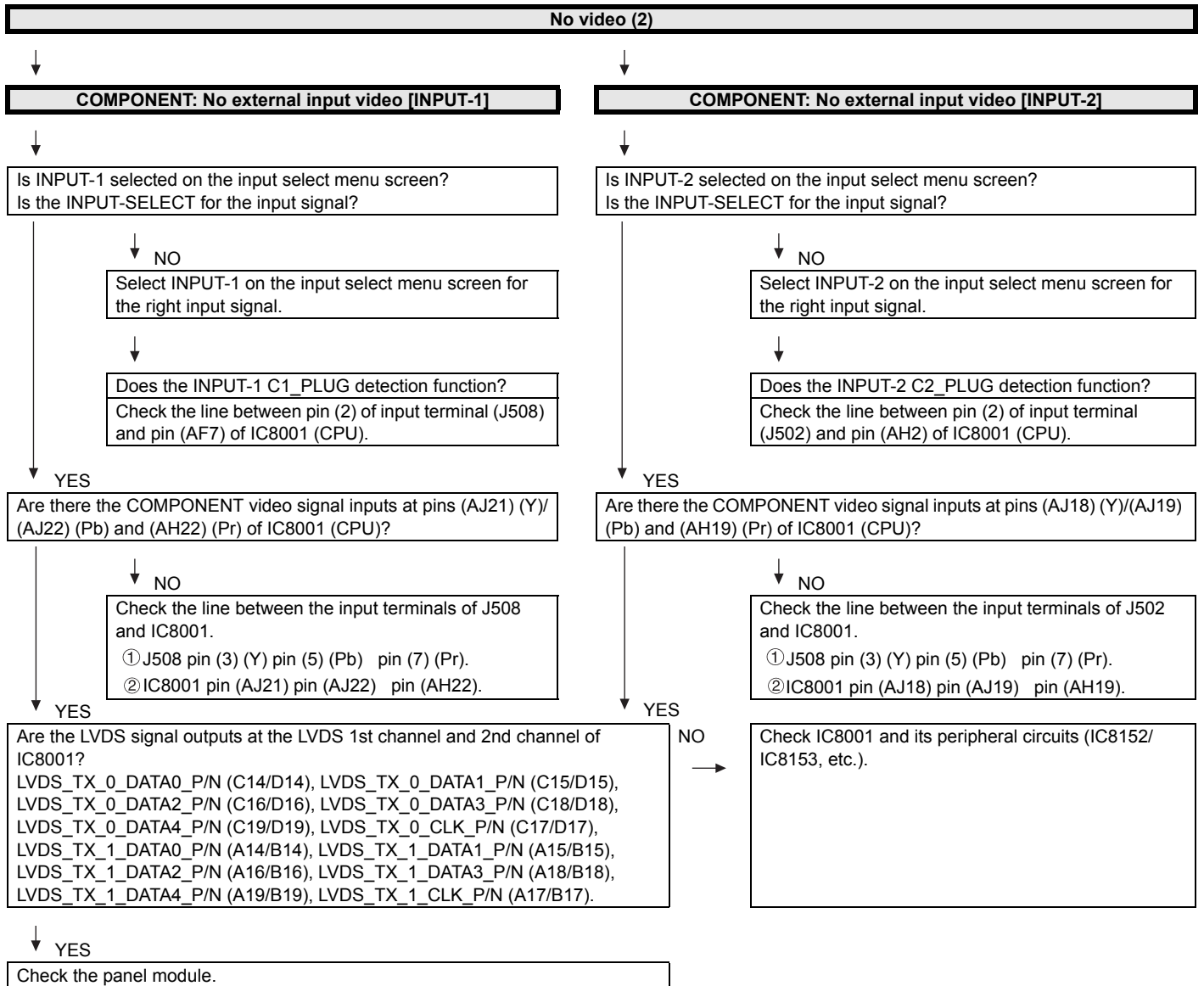

**No video (3)**

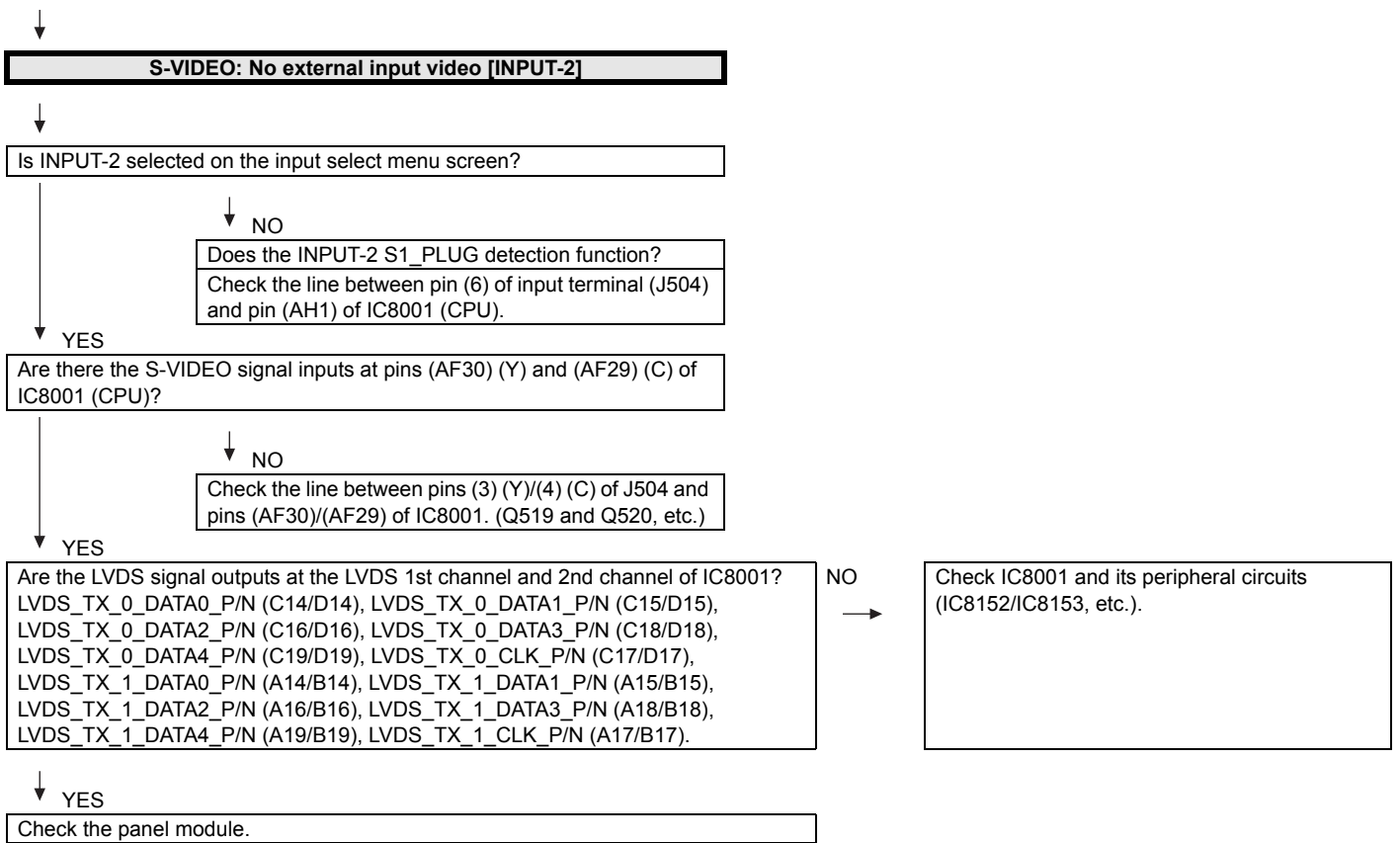

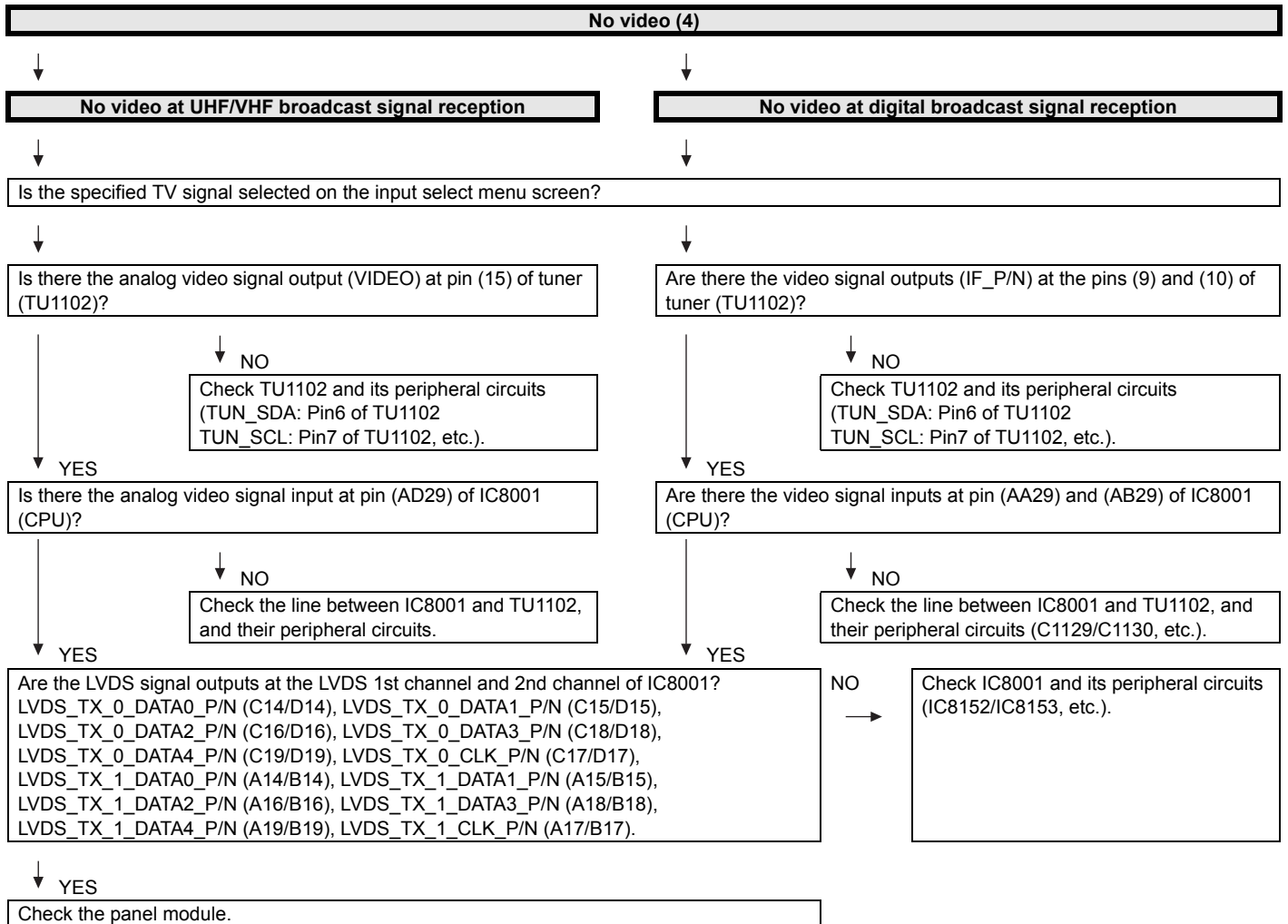

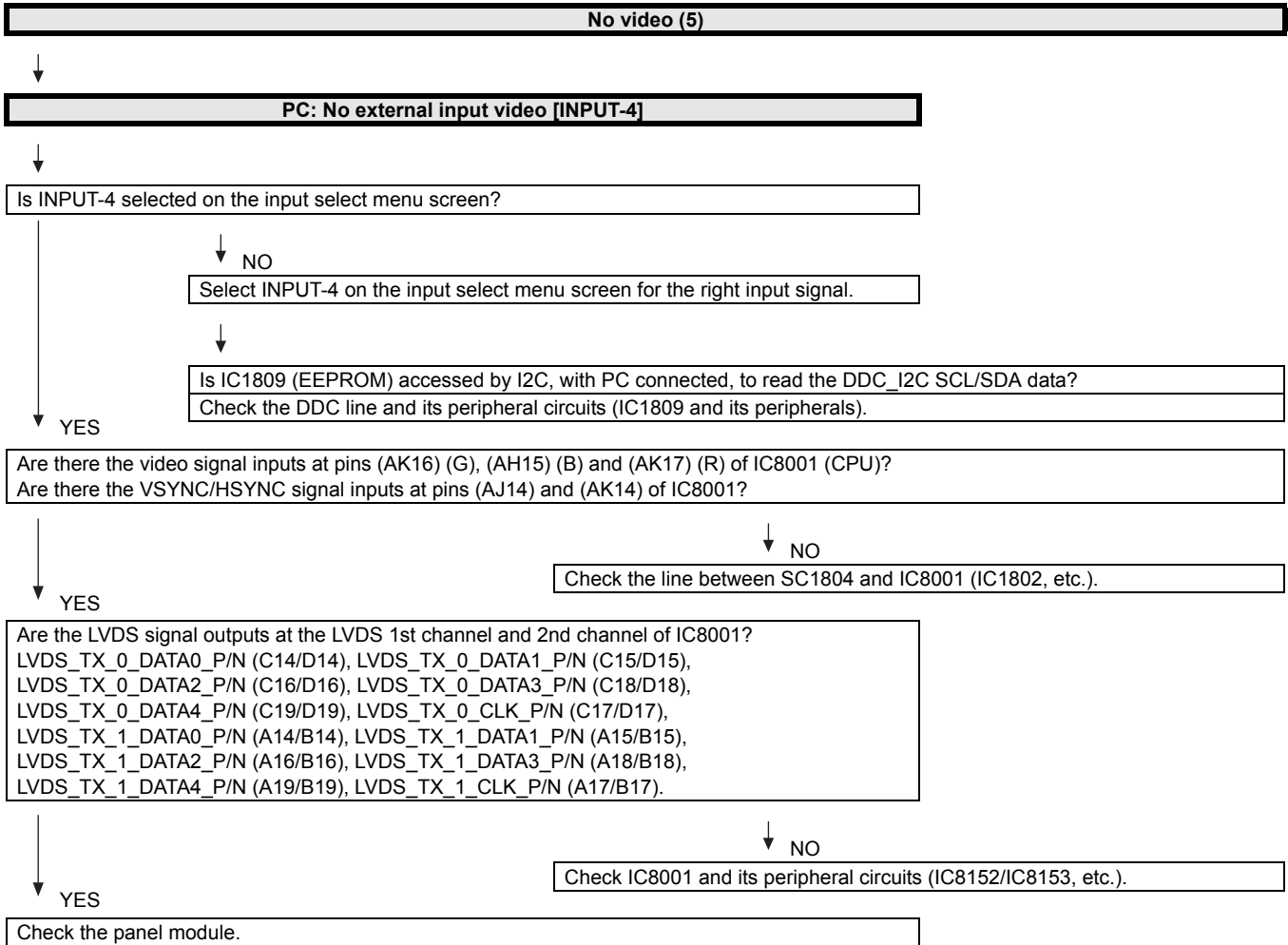

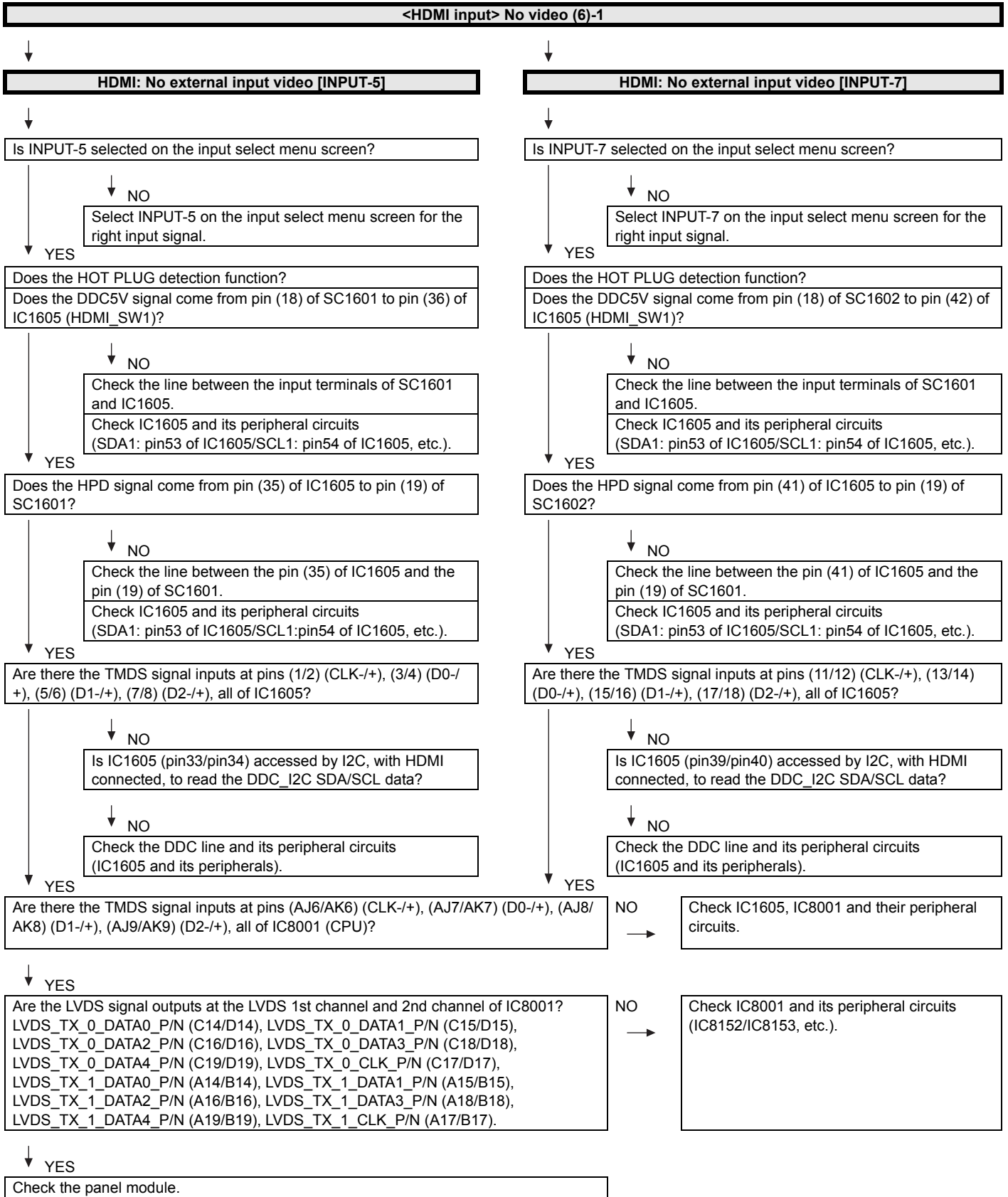

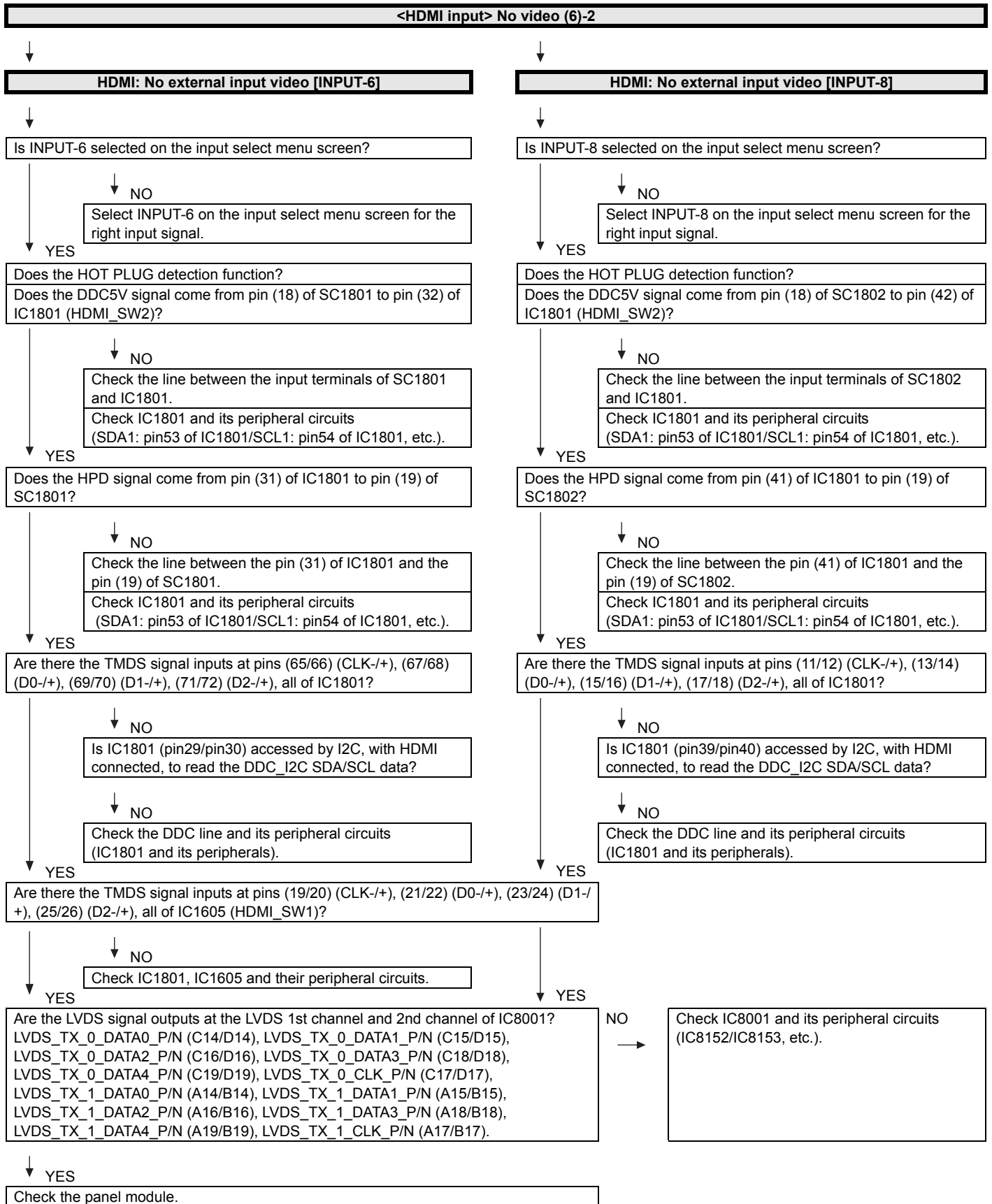

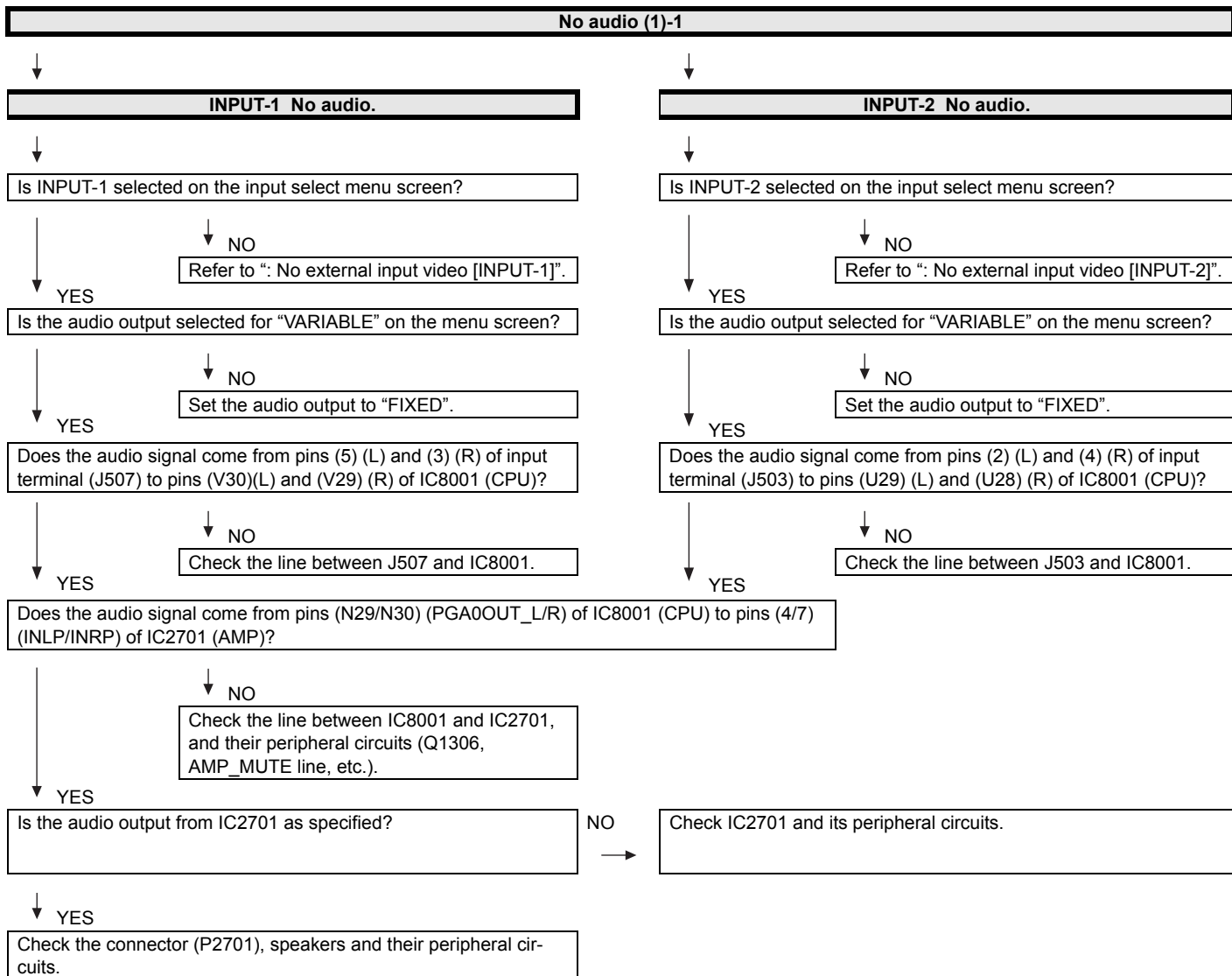

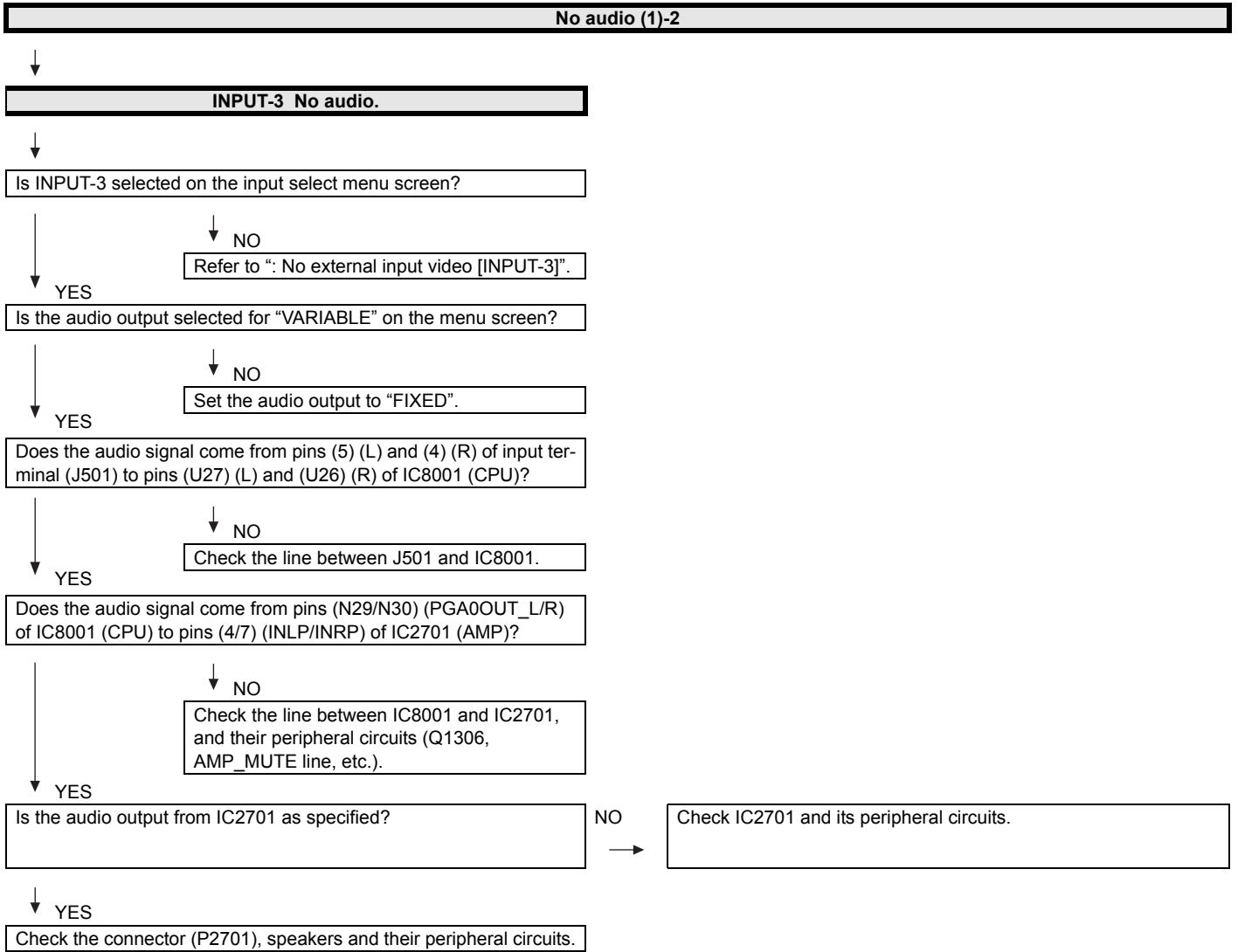

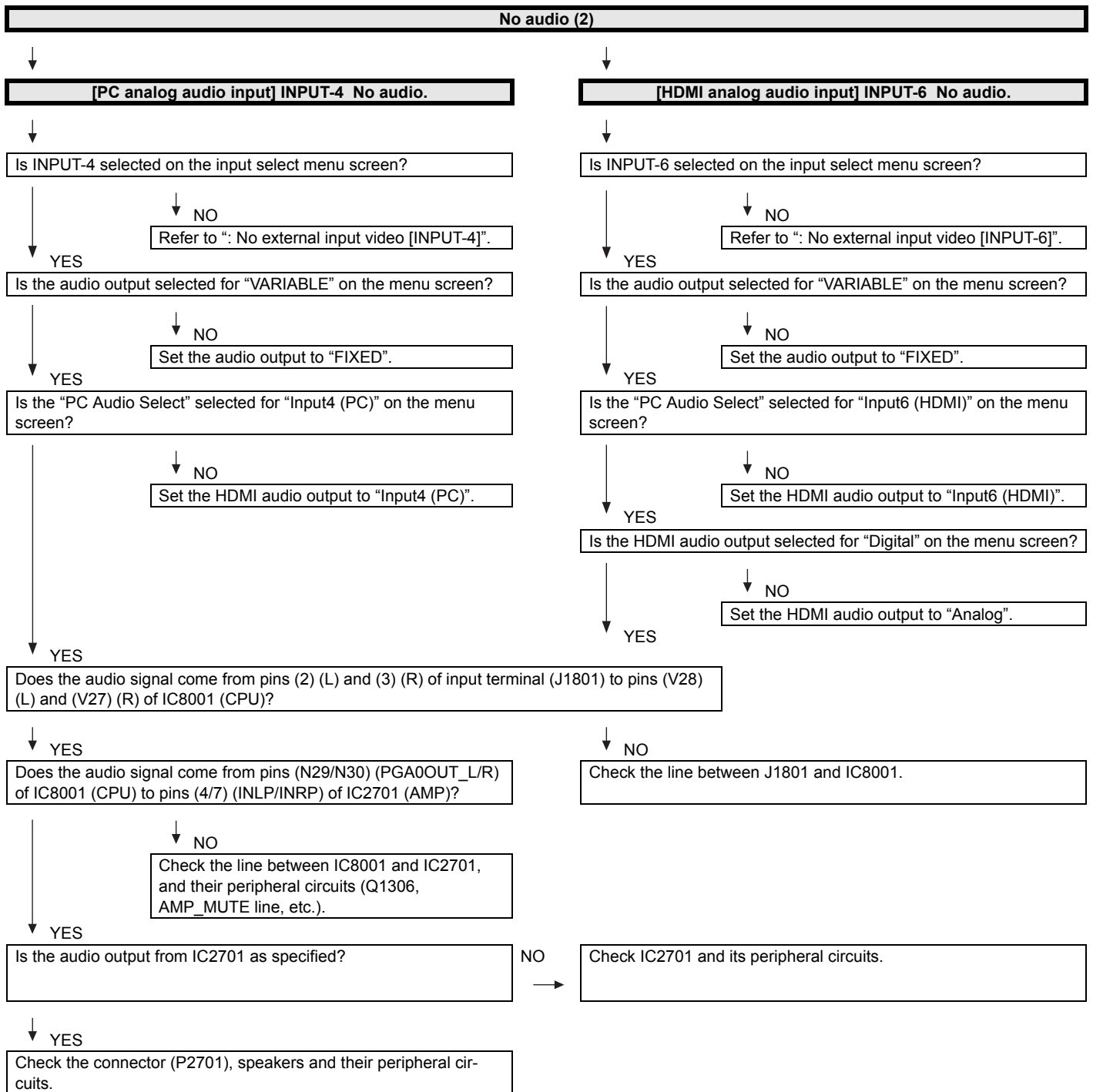

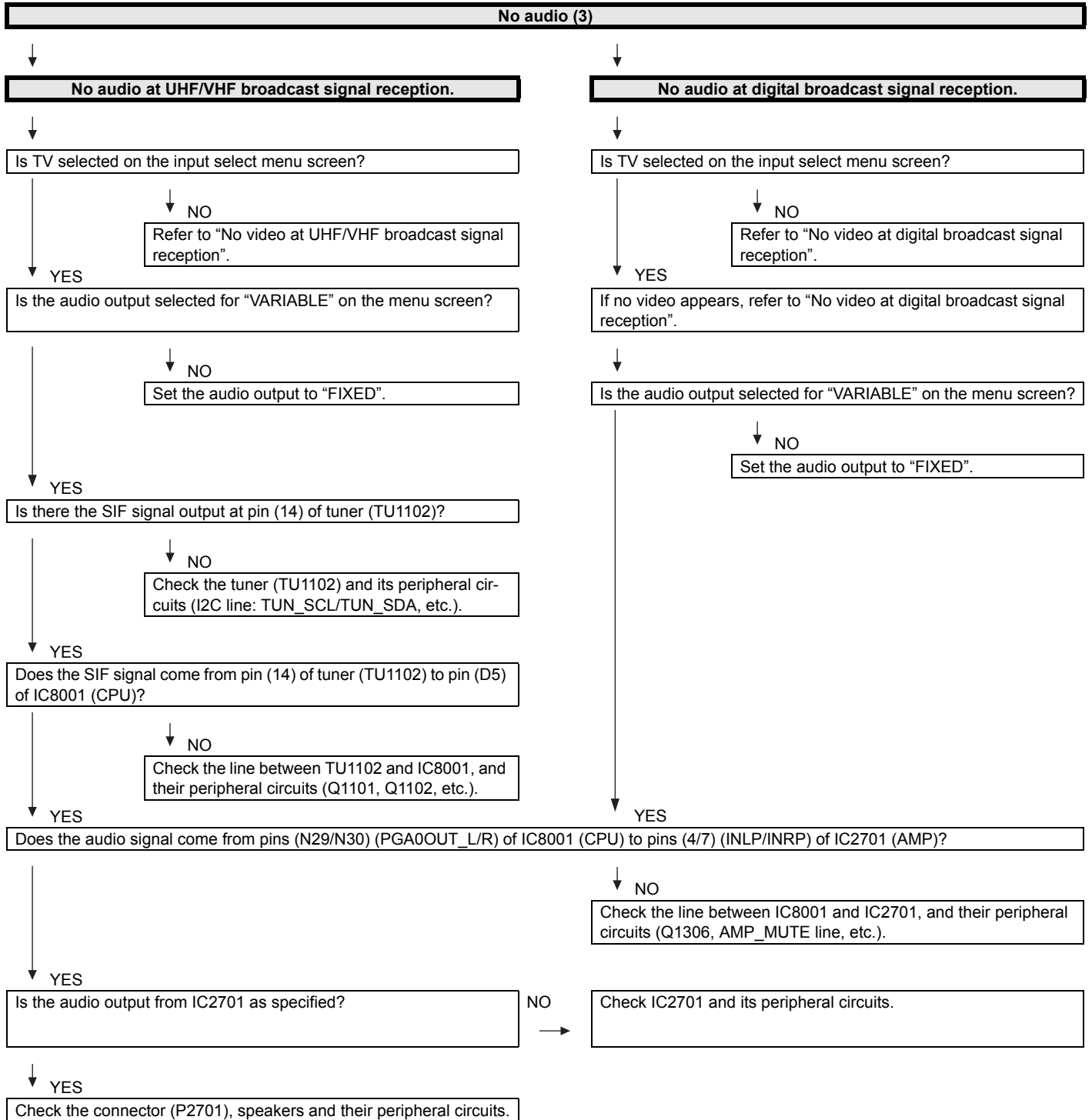

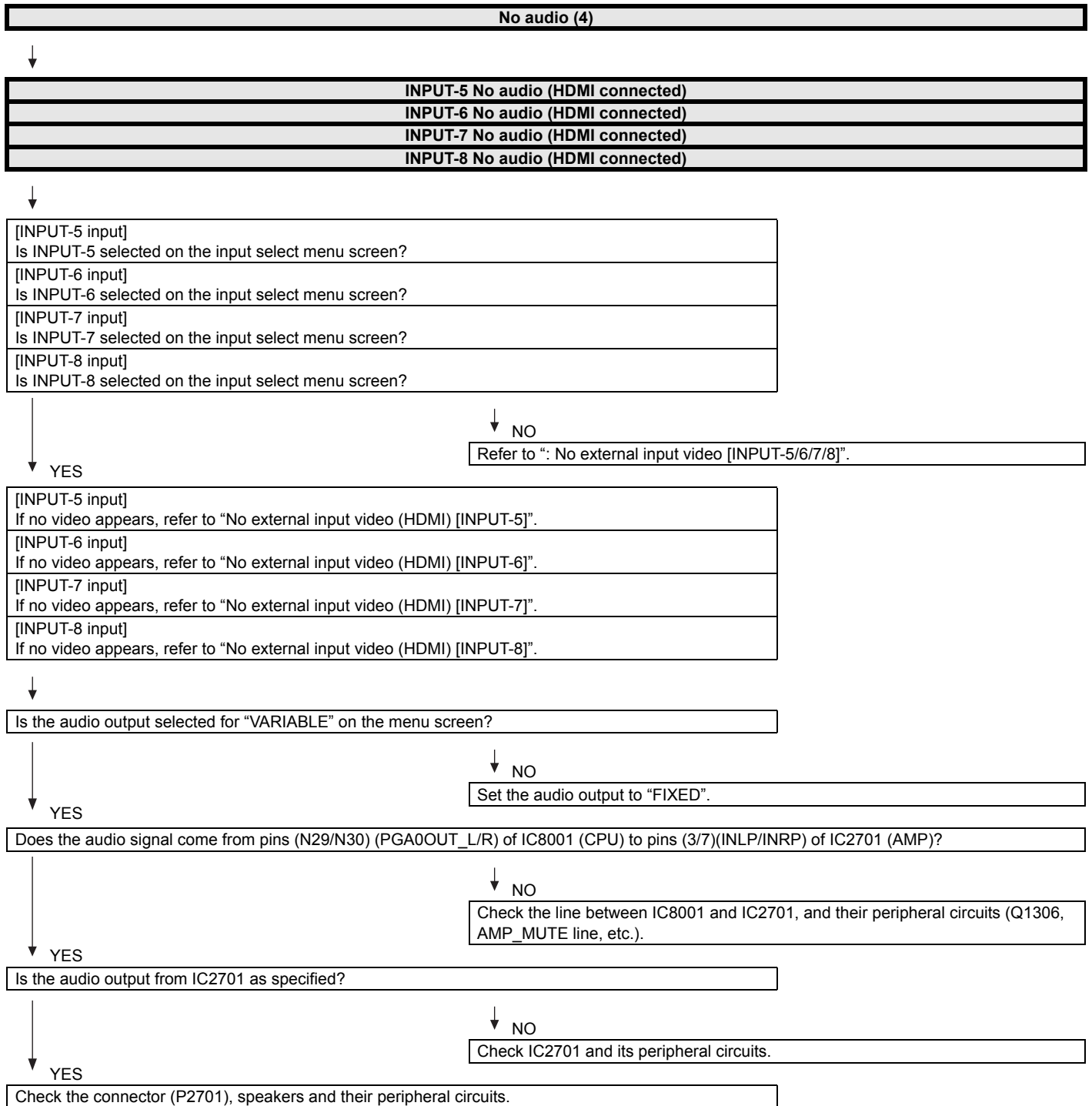

**No audio signal at Digital Audio Output terminal (Analog sound heard)**

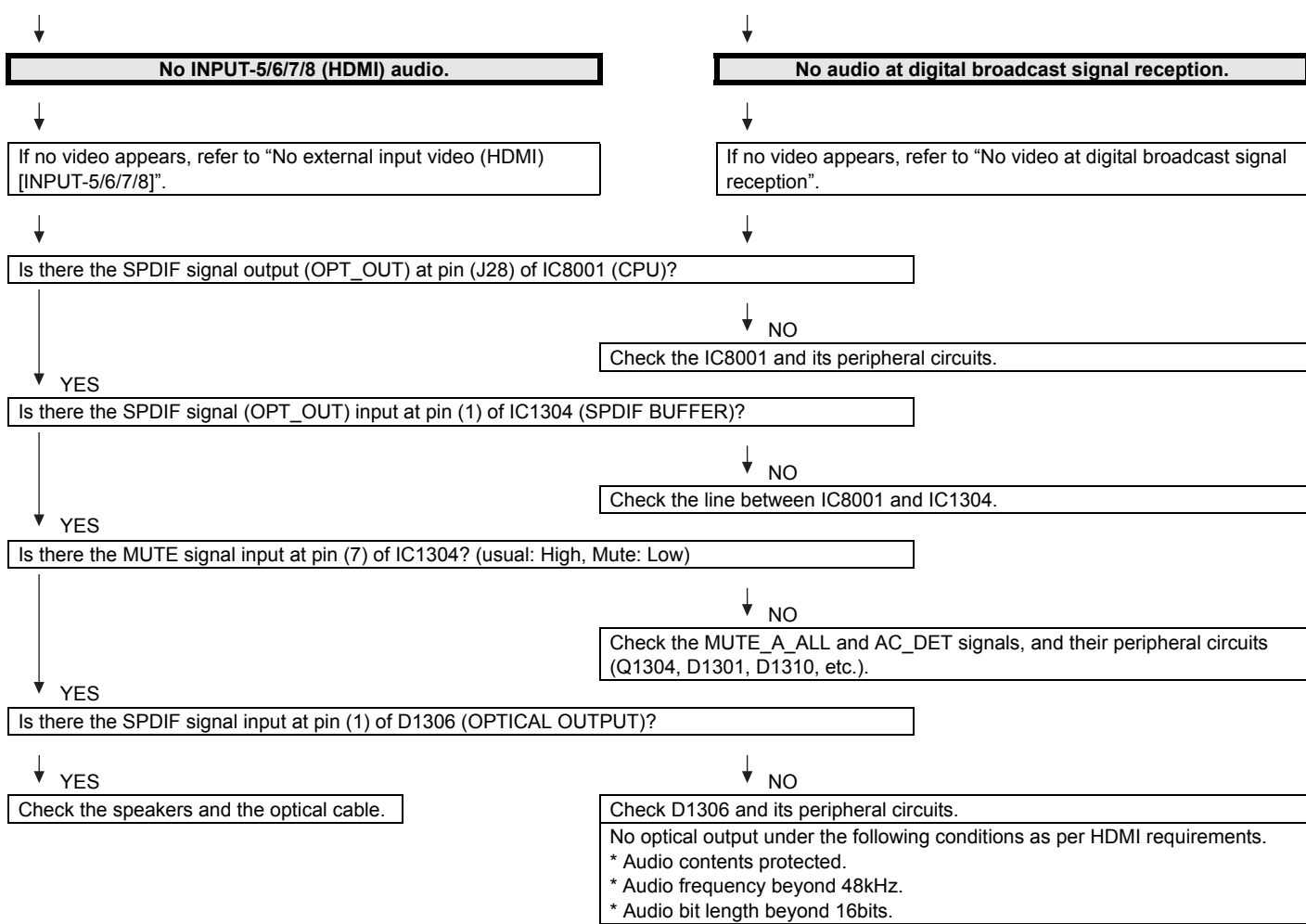

**No monitor audio output**

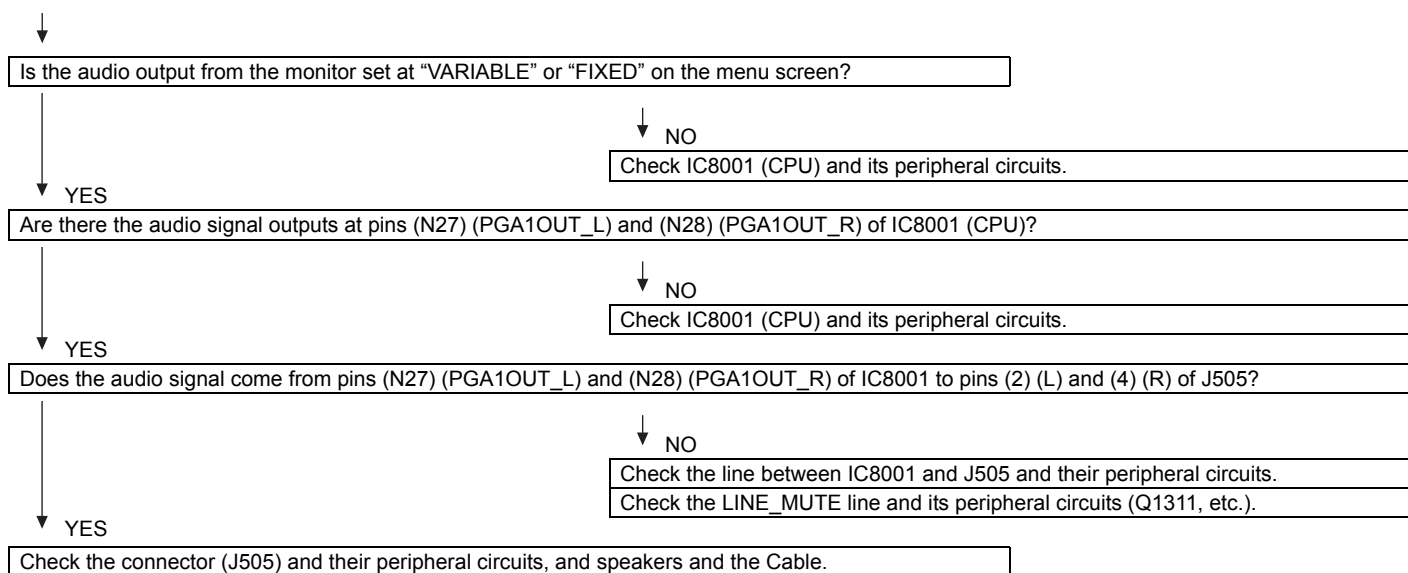



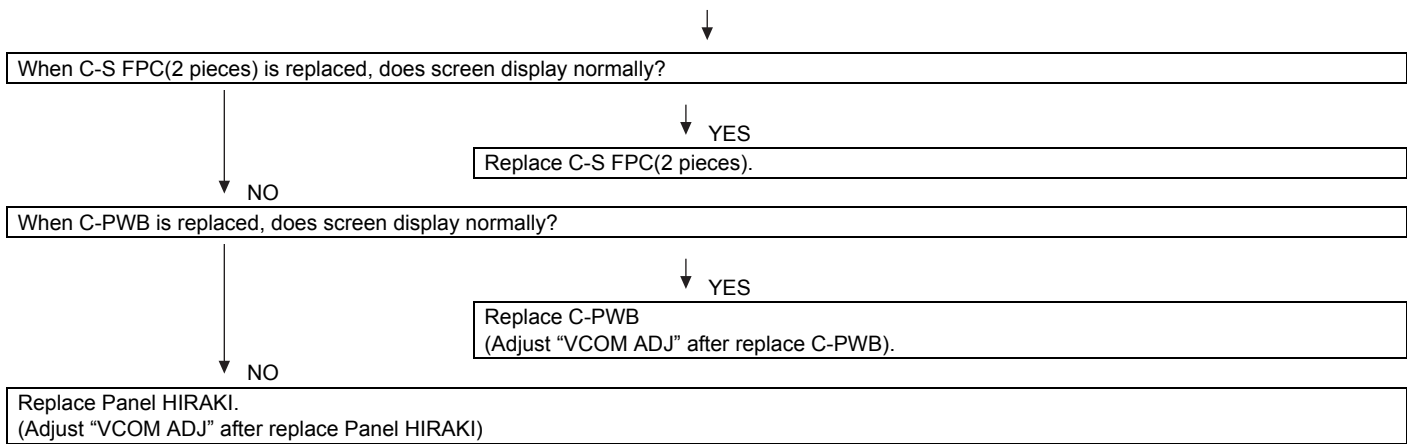

**Trouble Shooting Panel Module**









LED flashing timing chart for error notification.





**1) Power LED (Large classification)**

Error type	Power green LED operation (1 cycle)	Pins are monitor microprocessor (IC2002) pins.
Lamp error Flashes once: Fast	H: On  L: Off	ERR_PNL (40pin): L error. Confirmed after 8 consecutive detections at 64 ms intervals (detected only when the backlight is on). Note that after five detection counts, the lamp cannot be activated except in the monitoring process. [Clearing method of the accumulated counts] • Set "LAMP ERROR RESET" on page 2 of the process A to 0.
Power error Flashes twice	H: On  L: Off	Refer to "Power error details".
Communication error with the main CPU Flashes 3 times	H: On  L: Off	Refer to "Communication error details". Communication line error or main CPU communication error → Check debug statements for the main CPU. Communication line with the main CPU: TxD (28pin), RxD (29pin).
Monitor temperature error Flashes 5 times	H: On  L: Off	If the panel temperature is 60°C or more for 15 seconds or more in a row, CAUTION appears on the OSD ("TEMPERATURE" flashes in red in the lower right portion of the screen). If the panel temperature is 60°C or more for 25 seconds or more in a row, error standby is activated. [Avoidance method] Reduce the value of MONITOR MAX TEMP (temperature protection threshold) on page 35 of the process A.
Program area data destruction Flashes 8 times	H: On  L: Off	Flash ROM data error in the microprocessor. [Recovery method] Write the microprocessor software.

## 2) Power error details (Power LED flashes twice and OPC LED flashes)

Error type	OPC LED operation (1 cycle)	Pins are monitor microprocessor pins unless otherwise specified.
DET_15V error Flashes once	H: On  L: Off	DET_15V (34pin) error (L). UR13V is not applied. If error is detected during operation, error standby is activated by polling.
DET_D3V3 error Flashes twice	H: On  L: Off	DET_D3V3 (36pin) error (L). D3.3V is not applied. If error is detected during operation, error standby is activated by polling.
DET_5V error Flashes 3 times	H: On  L: Off	DET_5V (33pin) error (L). 5V is not applied. If error is detected during operation, error standby is activated by polling.
PNL_12V error Flashes 5 times	H: On  L: Off	DET_PNL_12V (35pin) error (L). Panel power is not applied. If error is detected during operation, error standby is activated by polling.
Main error Flashes 7 times	H: On  L: Off	Main microprocessor detection error (AMP error, etc.). Details are displayed in "ERROR STANDBY CAUSE" on page 1 of the process A for the main microprocessor.
TCON ROM error Flashes 8 times	H: On  L: Off	LCD controller ROM error. It is notified by communication from the main CPU.

## 3) Communication error details (Power LED flashes 3 times and OPC LED flashes)

Error type	OPC LED operation (1 cycle)	Basically, log analysis of debug print statements or communication log analysis by a bus monitor is performed.
Initial communication reception error Flashes once	H: On  L: Off	Initial communication from the main CPU is not received. (Request for the monitor model No. is not received after canceling the reset.) → Communication line error or main CPU start-up failure.
Time-out setting reception error Start-up confirmation reception error Flashes twice	H: On  L: Off	Time-out setting and start-up mode change from the main CPU is not received (Start-up communication of time-out setting and start-up mode change is not received.) → Main CPU start-up failure or monitor microprocessor reception failure.
Regular communication error Flashes 3 times	H: On  L: Off	Regular communication that is performed at 1 second intervals in the normal operation is interrupted. → Main CPU operation failure or monitor microprocessor reception failure.

## MONITOR\_ERR\_CAUSE list

No.		Description
Dec.	Hex.	
0	0	No error
1	1	5V detection error
2	2	Panel 12V detection error
3	3	15V detection error
4	4	D3.3V detection error
6	6	Lamp error
8	8	Main CPU reset cancel - Start-up completion command reception time-out
9	9	Start-up completion command reception - Time-out setting command reception time-out
10	A	Time-out setting command reception - Start-up reason change command reception time-out
11	B	Regular communication time-out
12	C	Temperature protection
16	10	Error notification from the main CPU
17	11	Time-out during ending sequence
18	12	TCON ROM error

## CHAPTER 7. MAJOR IC INFORMATIONS

### [1] MAJOR IC INFORMATIONS

#### 1. MAJOR IC INFORMATIONS

##### 1.1. IC1605, IC1801 (VHiSii9287+-1Q)

This IC is 4 input and 1 output HDMI port processor.

It integrated TMDS receiver and transmitter cores capable of receiving and transmitting at 2.25Gbps (Supports video resolutions up to 1080p, 60Hz, 12bit.).

The Equalizer circuits to adapt long cable are integrated in This IC.

EDID and DDC support for 4 HDMI/DVI ports and 1 VGA port (This IC includes 256-byte NVRAM and 256-byte SRAM for each port (5 total).).

##### 1.2. IC2002 (RH-iXC786WJN4Q)

The monitor microprocessor is intended to communicate with the main microprocessor and to operate the system.

It also controls power of the entire system.

##### 1.3. IC2701 (VHiYDA148QZ-1Y)

The Class-D type digital audio power amplifier YDA148QZ gives maximum continuous output of 10 W/ch.

##### 1.4. IC8001 (RH-iXC579WJQZQ)

This LSI is FULL HIGH-DEFINITION 1080P DIGITAL TV SYSTEM-ON-A-CHIP.

It combines a cable/terrestrial 64/256-QAM and 8-VSB receiver, a transport processor, a digital audio processor, a high definition (HD) MPEG video decoder, 2D graphics processing, digital processing of analog video and audio, analog video digitizer and DAC functions, stereo high-fidelity audio DACs, HDMI receivers for 1080p 60 inputs, a 625-MHz processor, and a peripheral control unit providing a variety of television control functions.

The cable/terrestrial receiver directly samples a tuner output with an analog-to-digital converter (ADC).

The LSI digitally resample and demodulates the signal with recovered clock and carrier timing, filters and equalizes the data, and passes soft decisions to an ATSC/A74 and ITU-T J.83 Annex B-compatible decoder.

It has an MPEG-2 Digital Video Broadcasting (DVB)-compliant transport processor with advanced section filtering capability, DVB descrambler, and an MPEG-2 (MP@HL profile) video decoder.

Audio support includes a BTSC and a Dolby AC3/MPEG-2 Layer 1, 2, audio decoder.

The LSI provides analog and digital audio/video outputs.

A SPDIF output and a pair of analog outputs (L-R) are provided via the integrated audio DACs.

The NTSC analog video decoder is supported by its own motion adaptive deinterlacing and 3D comb filtering, including 1080i deinterlacing.

The LSI includes advanced 2D graphics processing.

One transport stream input is included.

The LSI incorporates a complete ARM11-based microprocessor subsystem including caches with bridging to memory and a local bus, where external peripherals can be attached.

Integrated peripherals include two USB 2.0, three UARTs, counter/timers and GPIO controllers.

##### 1.5. IC8152/IC8153 (RH-iXC768WJQZQ)

These are 512M bit (32M x 16bit) DDR2-1066 synchronous DRAM.

##### 1.6. IC8453 (RH-iXC894WJQZQ)

The 512M-bit NAND flash memory device stores the main CPU program.

##### 1.7. IC8454 (VHiS24CS64A-1Y)

This is 64k-bit EEPROM device including the user setting.

##### 1.8. IC9003 (VHiM3221EiP-1Y)

This IC is a high speed, single-channel RS-232 transceiver interface device that operates from a single 3.3V power supply.

The device provides the electrical interface between an asynchronous communication controller and the serial-port connector.

This device operate at data signaling rates up to 460kbit/s.

All RS-232(Tout and Rin) and CMOS (Tin and Rout) inputs and outputs are protected against electrostatic discharge (up to +/- 15kV ESD protection).

CHAPTER 8. OVERALL WIRING/SYSTEM BLOCK DIAGRAM

[1] OVERALL WIRING DIAGRAM (LC-60E77UN/LC-C6077UN)

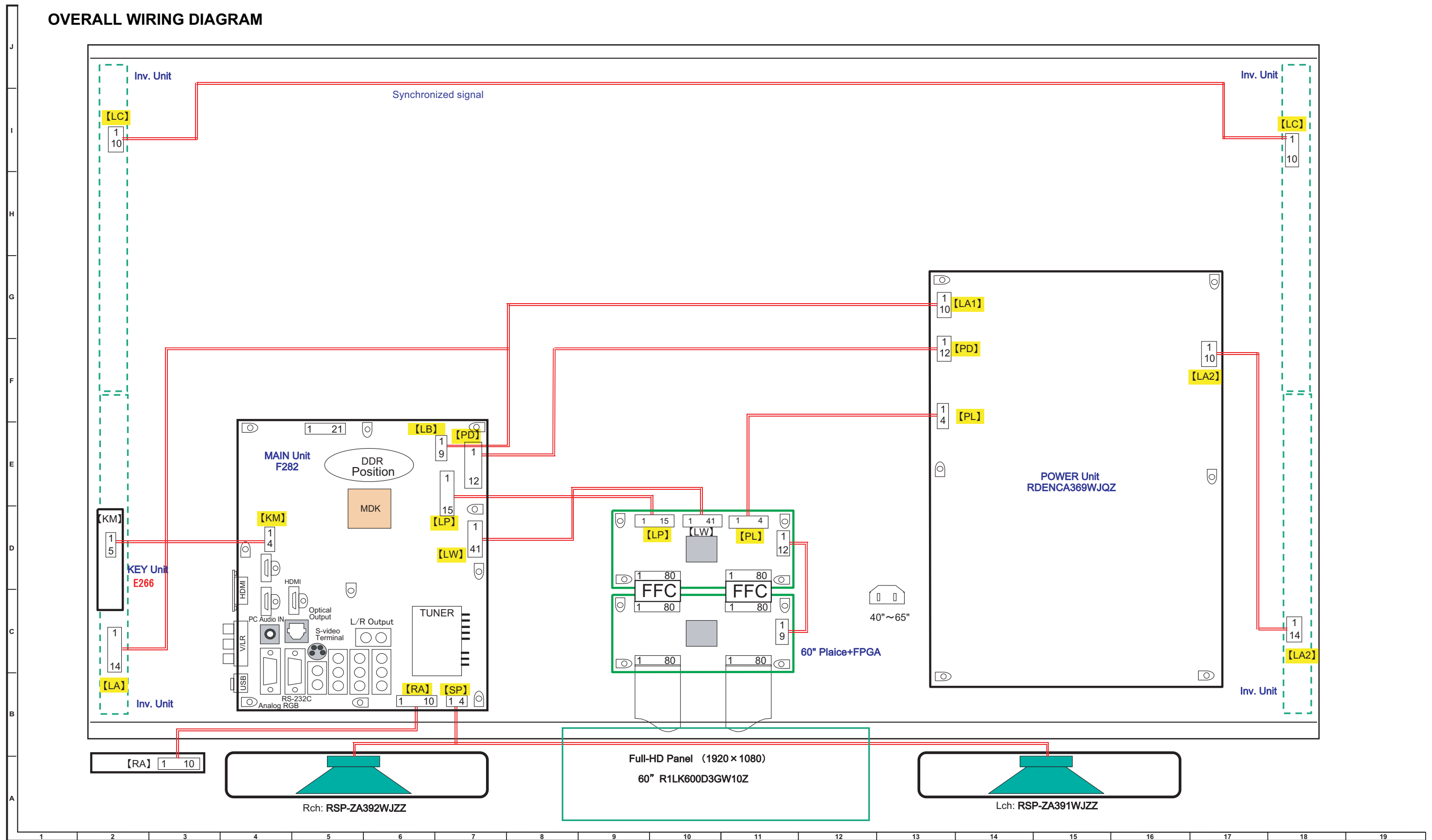

[2] OVERALL WIRING DIAGRAM (LC-65E77UM/LC-C6577UM)

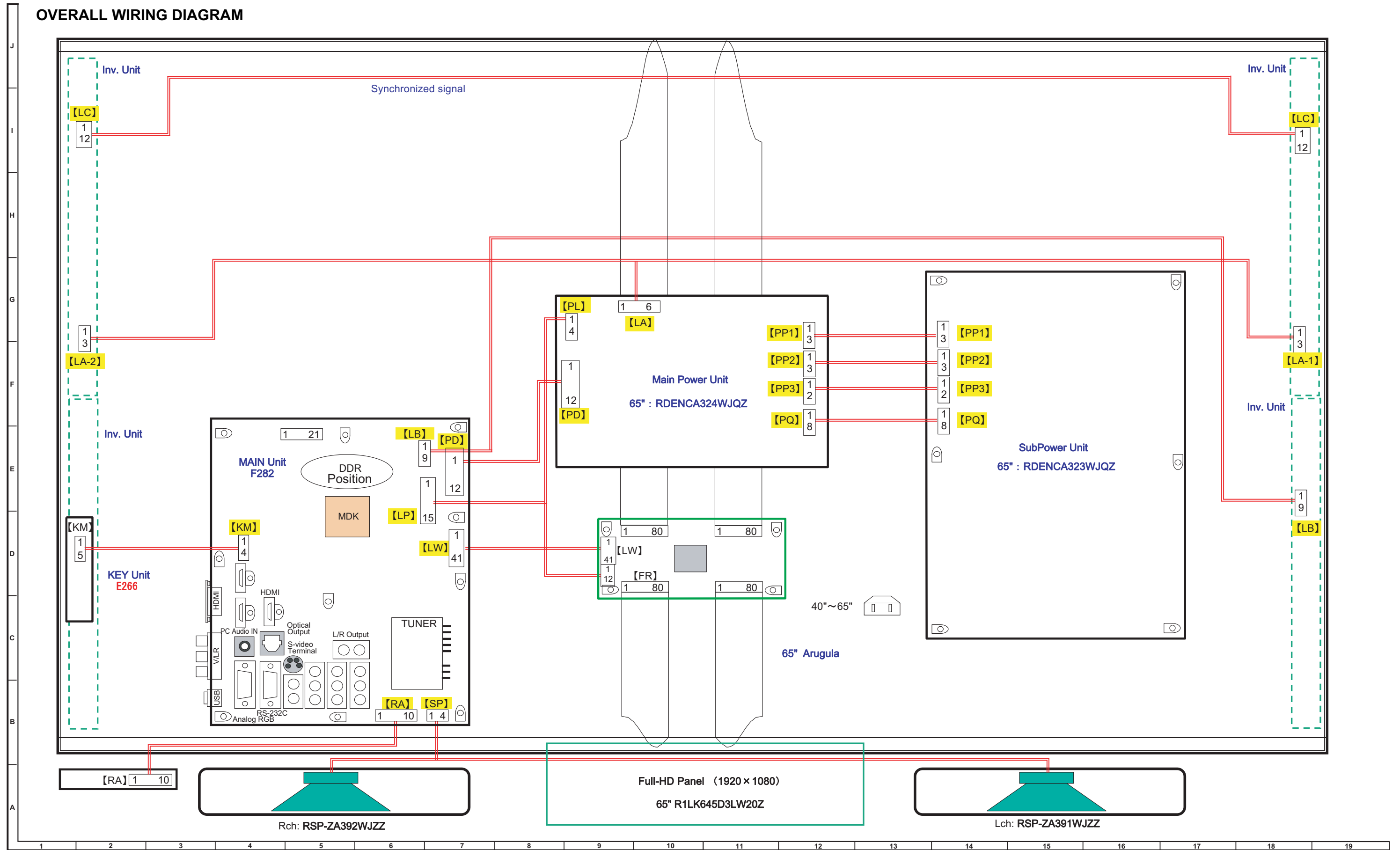

[3] SYSTEM BLOCK DIAGRAM

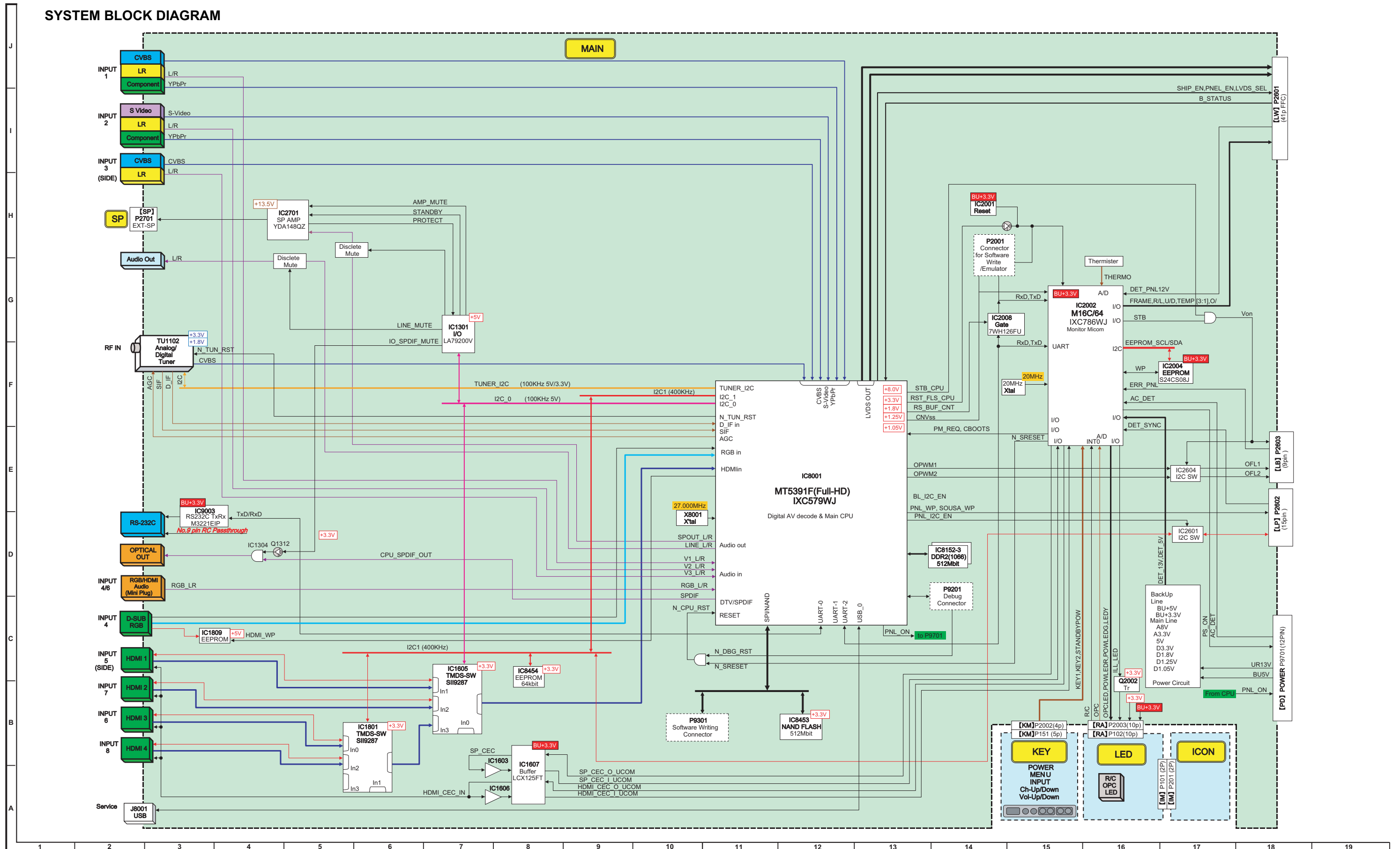

**CHAPTER 9. PRINTED WIRING BOARD ASSEMBLIES**

**[1] KEY Unit, R/C, LED Unit Unit**

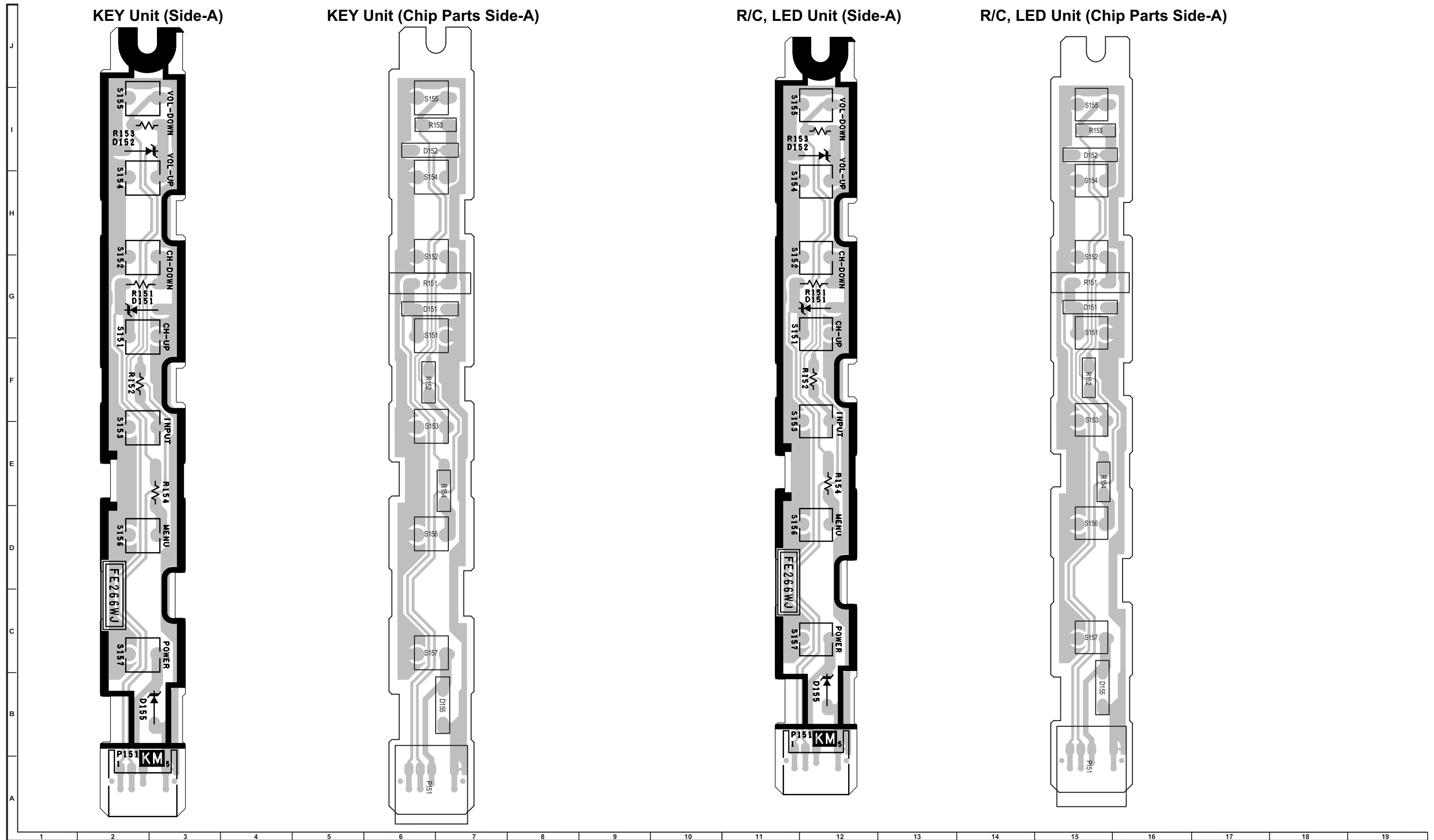

[2] MAIN Unit

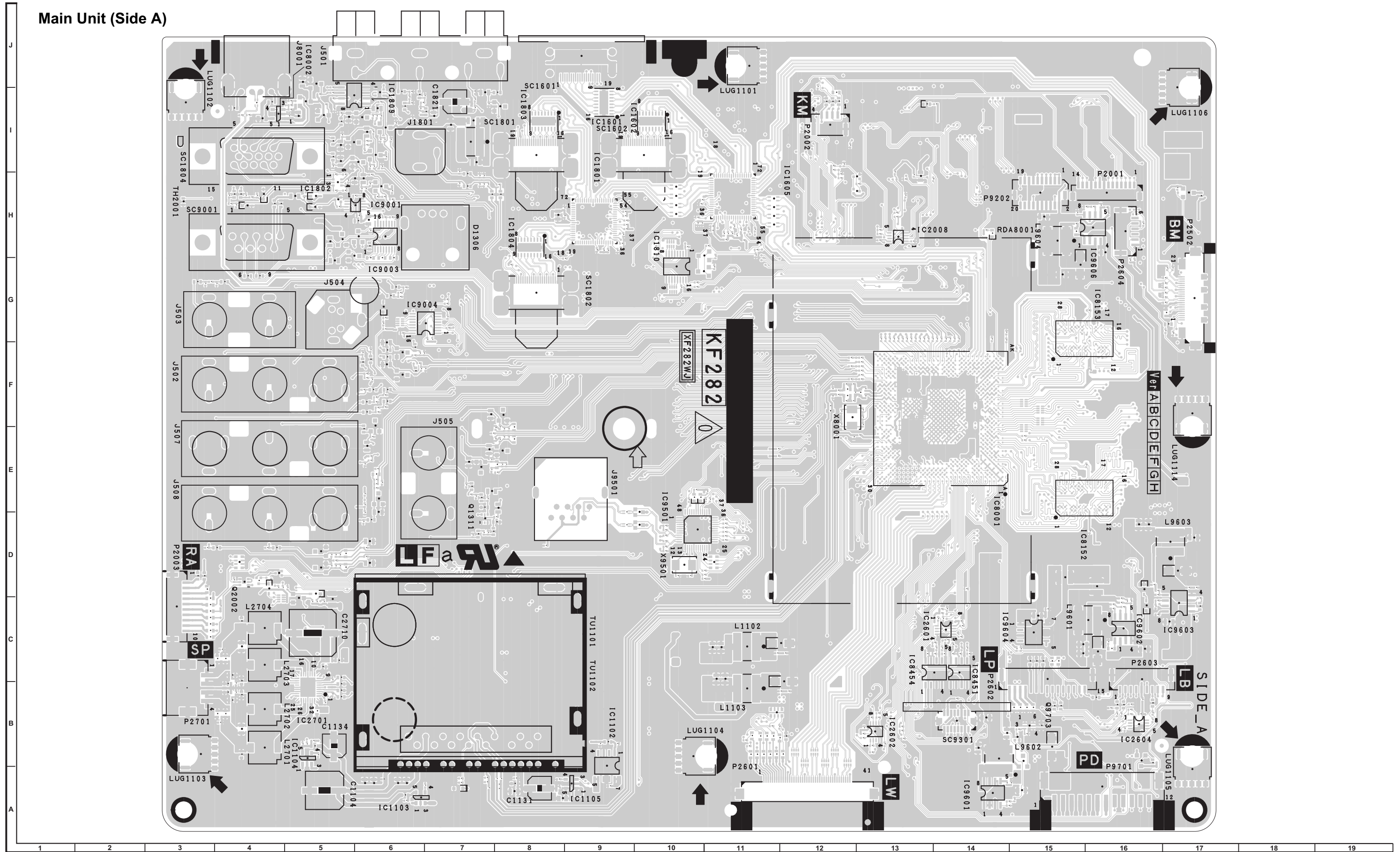

### MAIN Unit (Chip Side A)

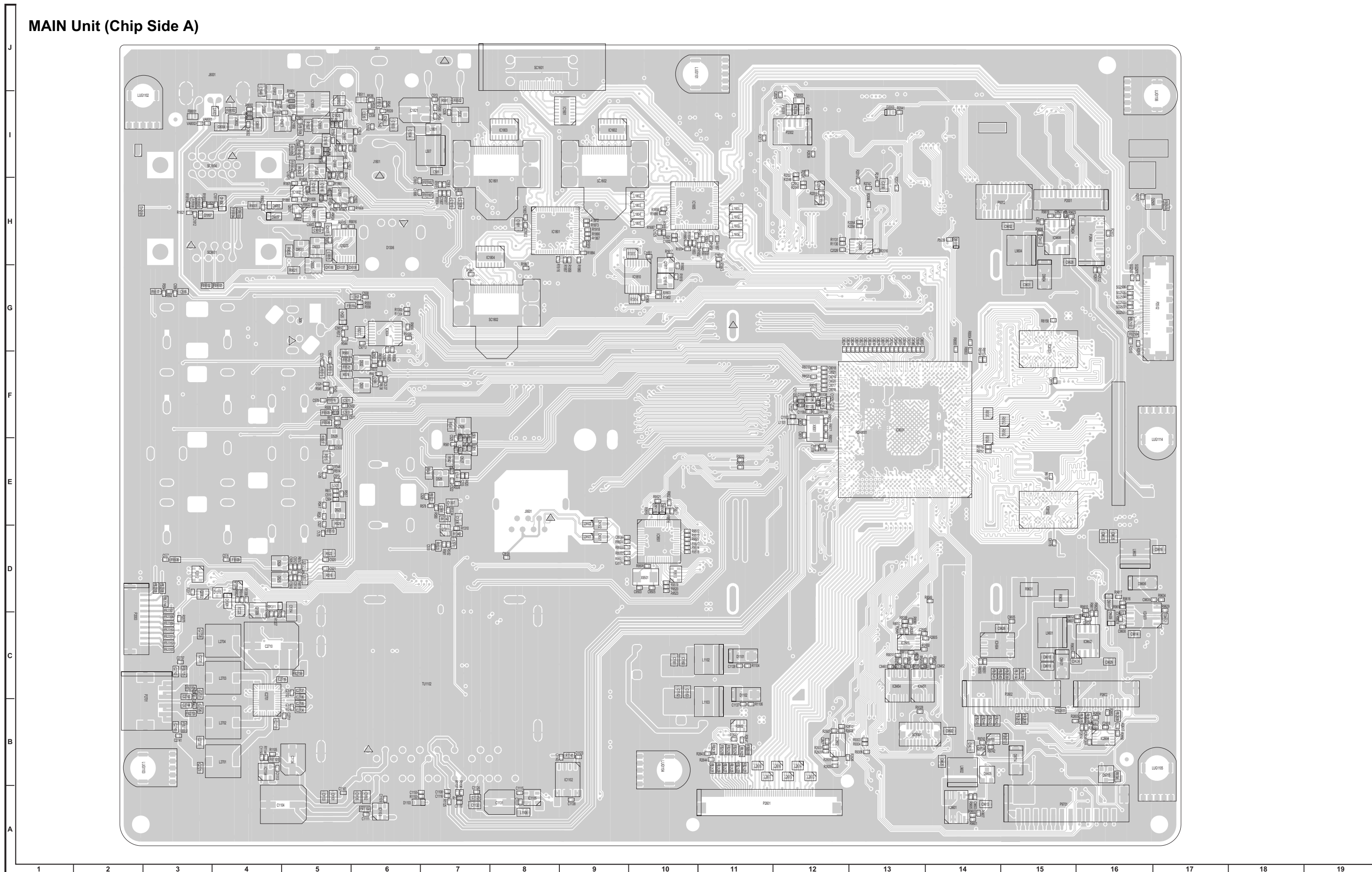

MAIN Unit (Side B)

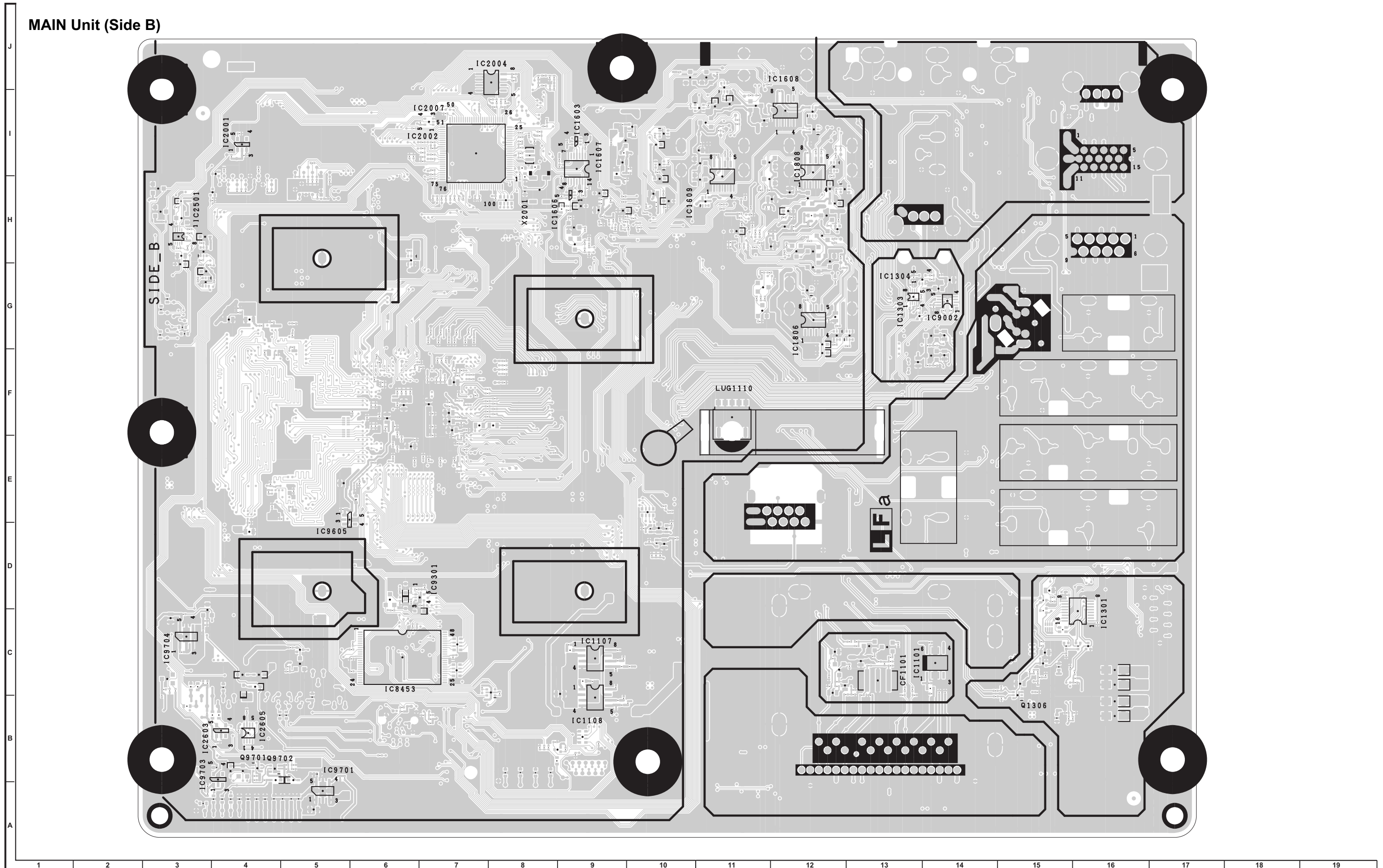

MAIN Unit (Chip Side B)



## CHAPTER 10. SCHEMATIC DIAGRAM

### [1] DESCRIPTION OF SCHEMATIC DIAGRAM

#### 1. VOLTAGE MEASUREMENT CONDITION:

- 1) The voltages at test points are measured on exclusive AC adaptor and the stable supply voltage of AC 120V. Signals are fed by a color bar signal generator for servicing purpose and the above voltages are measured with a 20k ohm/V tester.

#### 2. INDICATION OF RESISTOR & CAPACITOR:

##### RESISTOR

- 1) The unit of resistance " $\Omega$ " is omitted.  
(K=k $\Omega$ =1000 $\Omega$ , M=M $\Omega$ ).
- 2) All resistors are  $\pm 5\%$ , unless otherwise noted.  
(K=  $\pm 10\%$ , F=  $\pm 1\%$ , D=  $\pm 0.5\%$ )
- 3) All resistors are 1/16W, unless otherwise noted.

##### CAPACITOR

- 1) All capacitors are  $\mu\text{F}$ , unless otherwise noted.  
(P=pF= $\mu\mu\text{F}$ ).
- 2) All capacitors are 50V, unless otherwise noted.

##### CAUTION:

This circuit diagram is original one, therefore there may be a slight difference from yours.

##### SAFETY NOTES:

- 1) DISCONNECT THE AC PLUG FROM THE AC OUTLET BEFORE REPLACING PARTS.
- 2) SEMICONDUCTOR HEAT SINKS SHOULD BE REGARDED AS POTENTIAL SHOCK HAZARDS WHEN THE CHASSIS IS OPERATING.

##### IMPORTANT SAFETY NOTICE:

PARTS MARKED WITH "  $\triangle$  " (  ) ARE IMPORTANT FOR MAINTAINING THE SAFETY OF THE SET. BE SURE TO REPLACE THESE PARTS WITH SPECIFIED ONES FOR MAINTAINING THE SAFETY AND PERFORMANCE OF THE SET.

##### AVIS DE SECURITE IMPORTANT:

LES PIECES MARQUEES "  $\triangle$  " (  ) SONT IMPORTANTES POUR MAINTENIR LA SECURITE DE L'APPAREIL. NE REMPLACER CES PIECES QUE PAR DES PIECES DONT LE NUMERO EST SPECIFIE POUR MAINTENIR LA SECURITE ET PROTEGER LE BON FONCTIONNEMENT DE L'APPAREIL.

[2] SCHEMATIC DIAGRAM

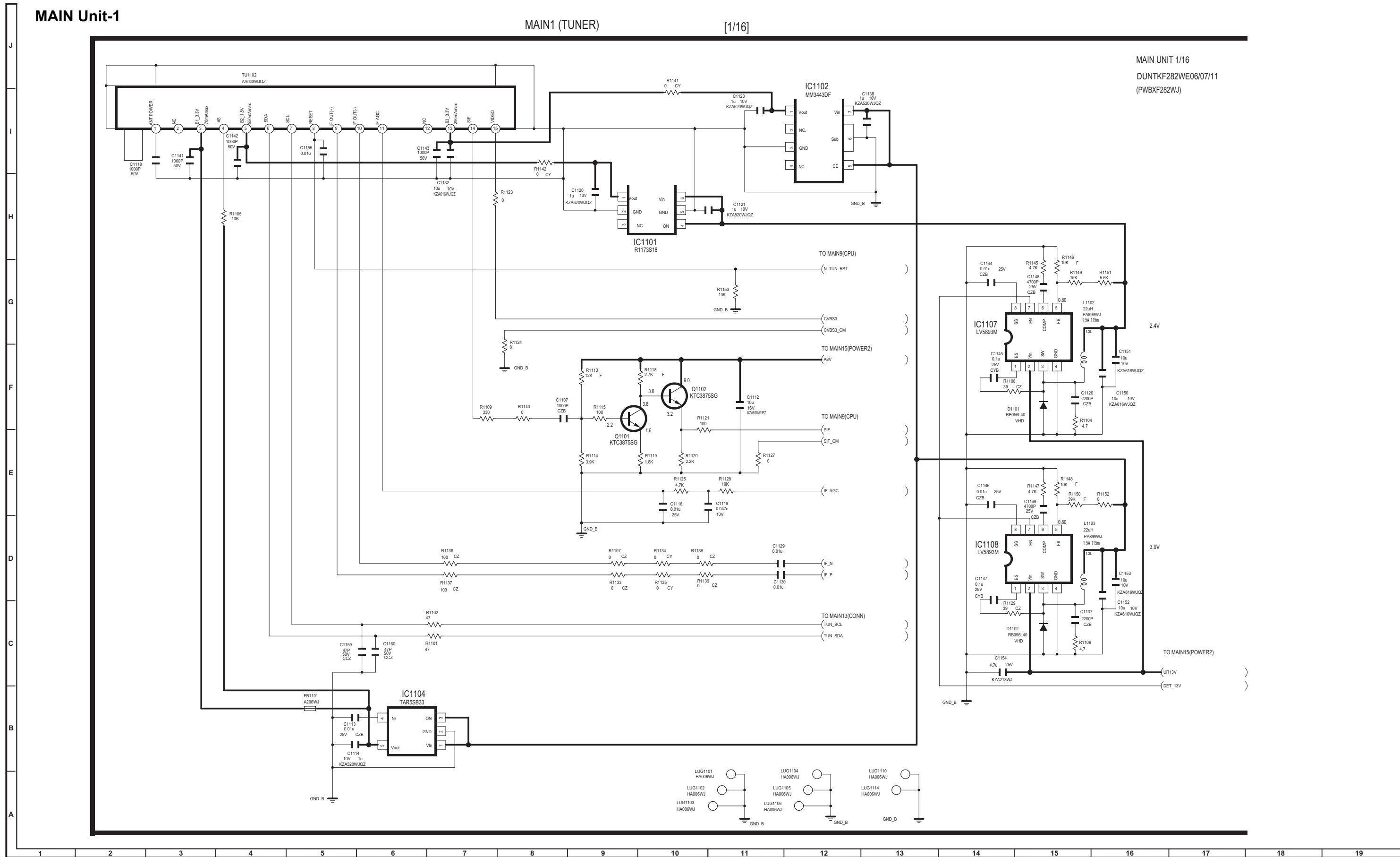

MAIN Unit-2

MAIN2(A\_TERM)

[2/16]

MAIN UNIT 2/16  
DUNTKF282WE06/07/11  
(PWBF282WJ)

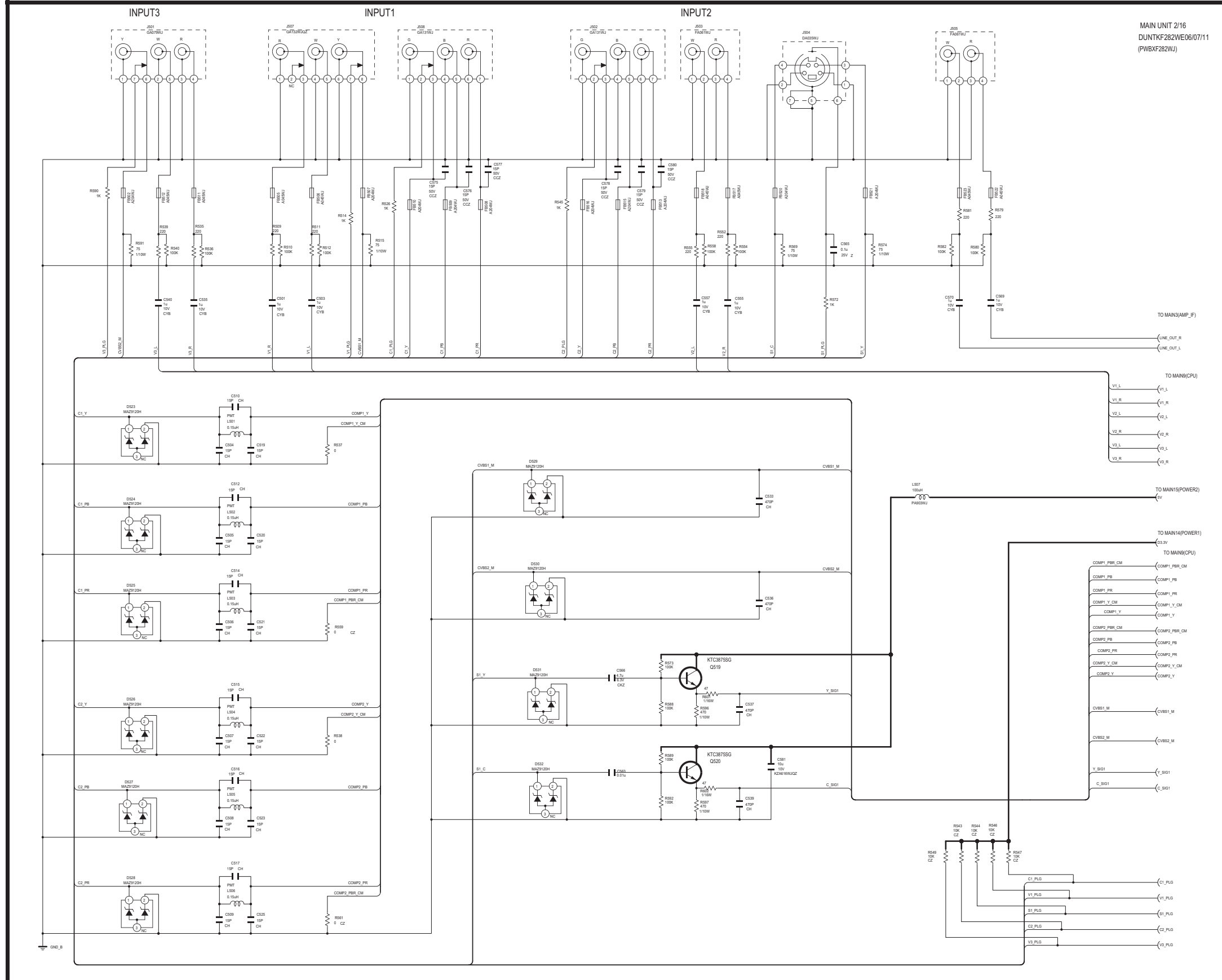

MAIN Unit-3

MAIN3 (AMP IF)

[3/16]

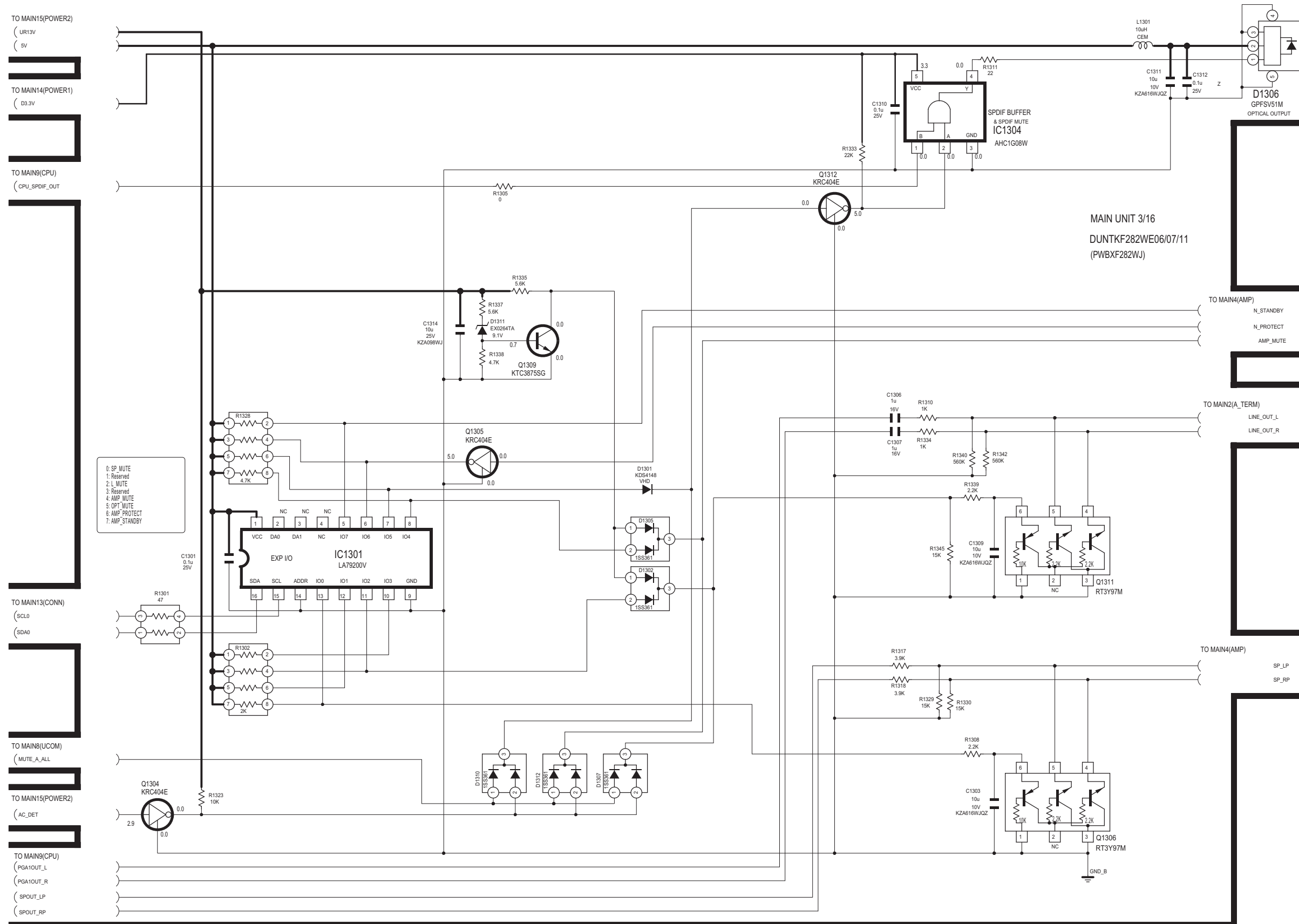

MAIN Unit-4

MAIN4(AMP)

[4/16]

MAIN UNIT 4/16  
DUNTKF282WE06/07/11  
(PWBXF282WJ)

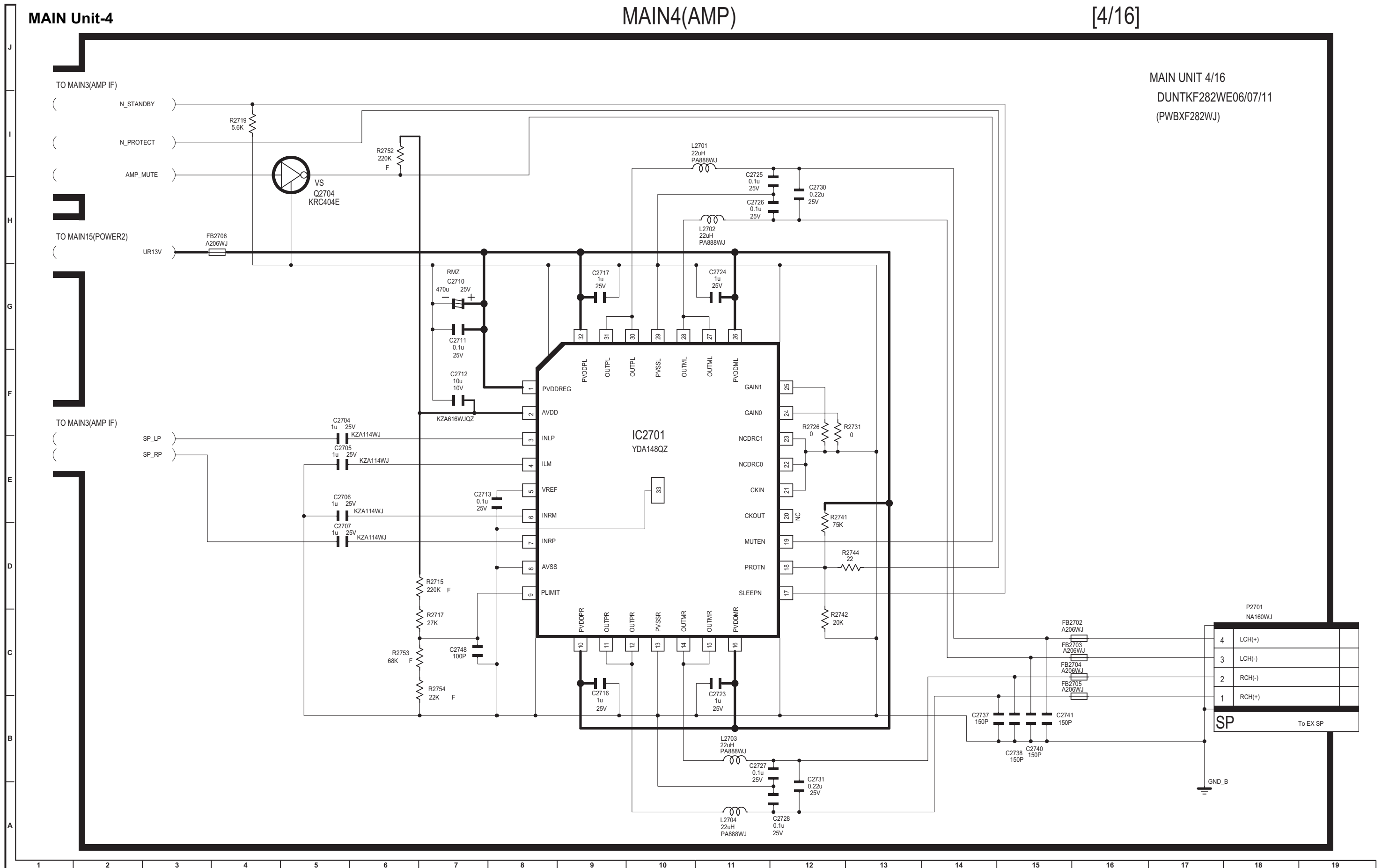



MAIN6 (HDMI\_SW2)

[6/16]

MAIN Unit-6

MAIN UNIT 6/16  
DUNTKF282WE38/07/11  
(PWBXF282W)

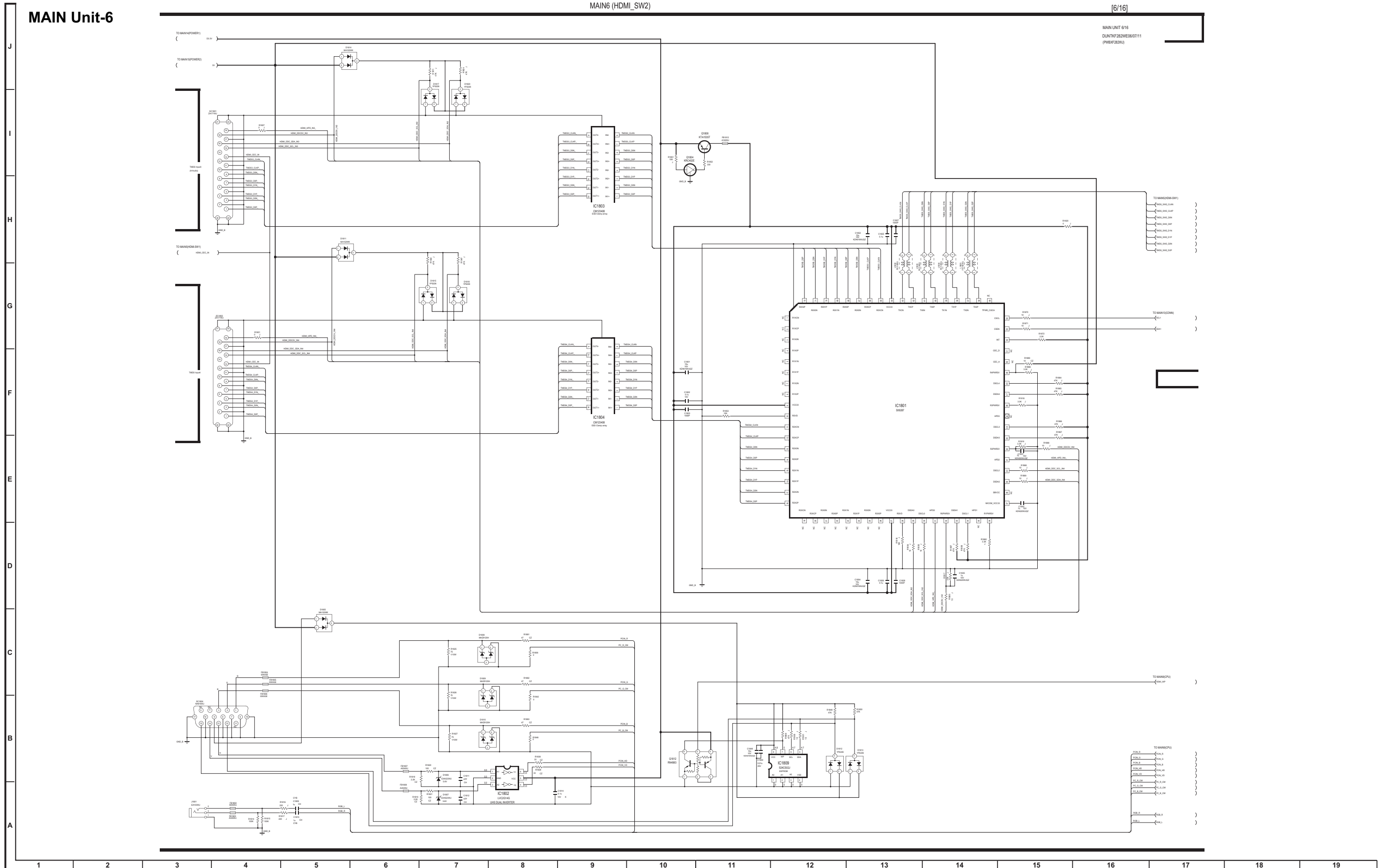

MAIN Unit-7

MAIN7 (PANEL)

[7/16]

MAIN UNIT 7/16  
DUNTKF282WE06/07/11  
(PWBXF282WJ)

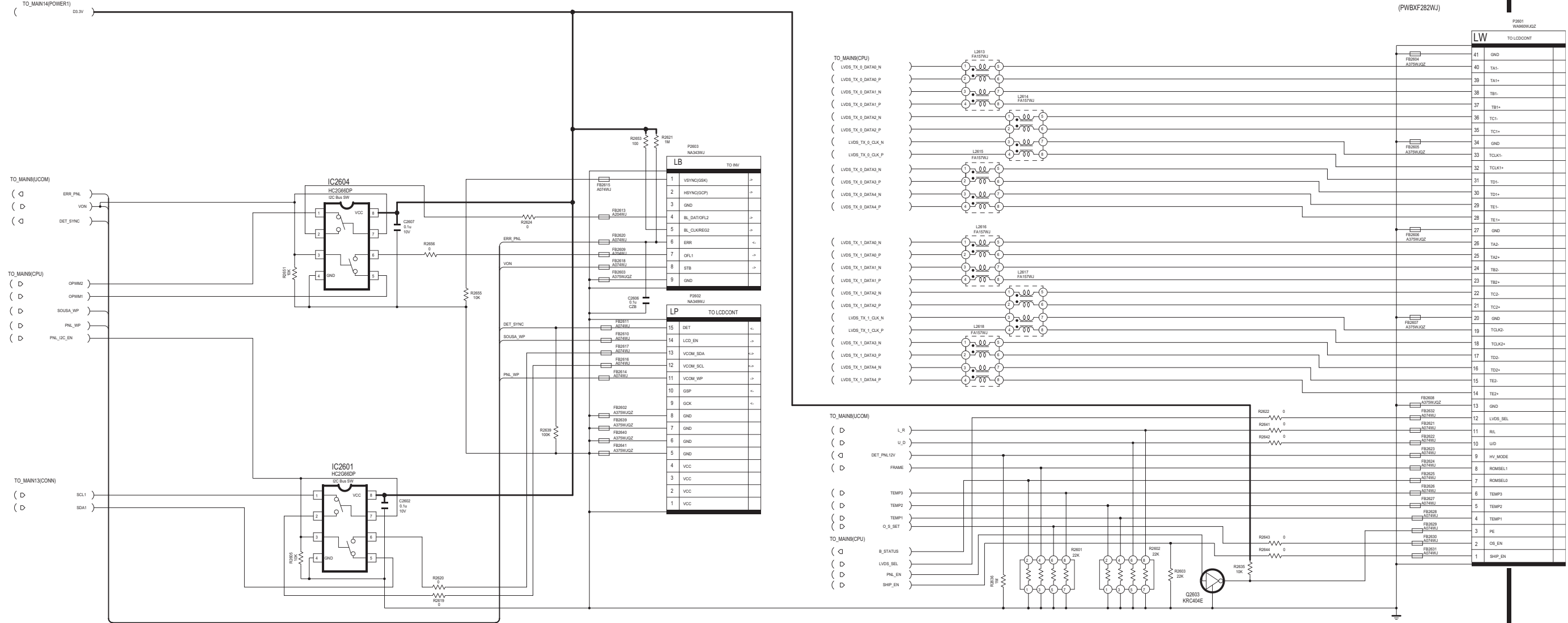

MAIN Unit-8

MAIN8 (UCOM)

[8/16]

MAIN UNIT 8/16  
DUNTKF282WE06/07/11  
(PWBXF282WJ)

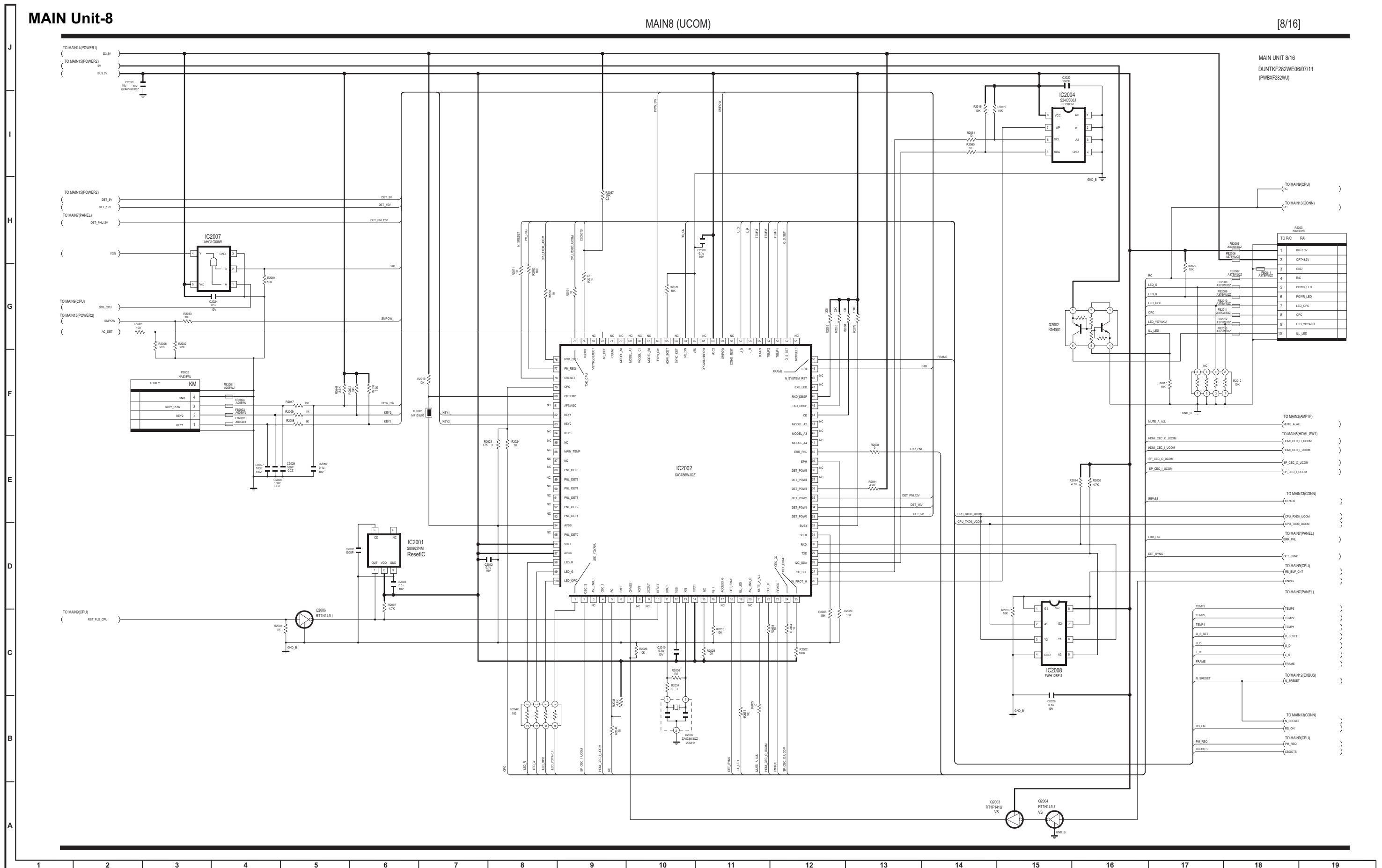

MAIN Unit-9

MAIN9 (CPU)

[9/16]

MAIN UNIT 916  
DUNTKF282WE06/07/11  
(PWBF282WJ)

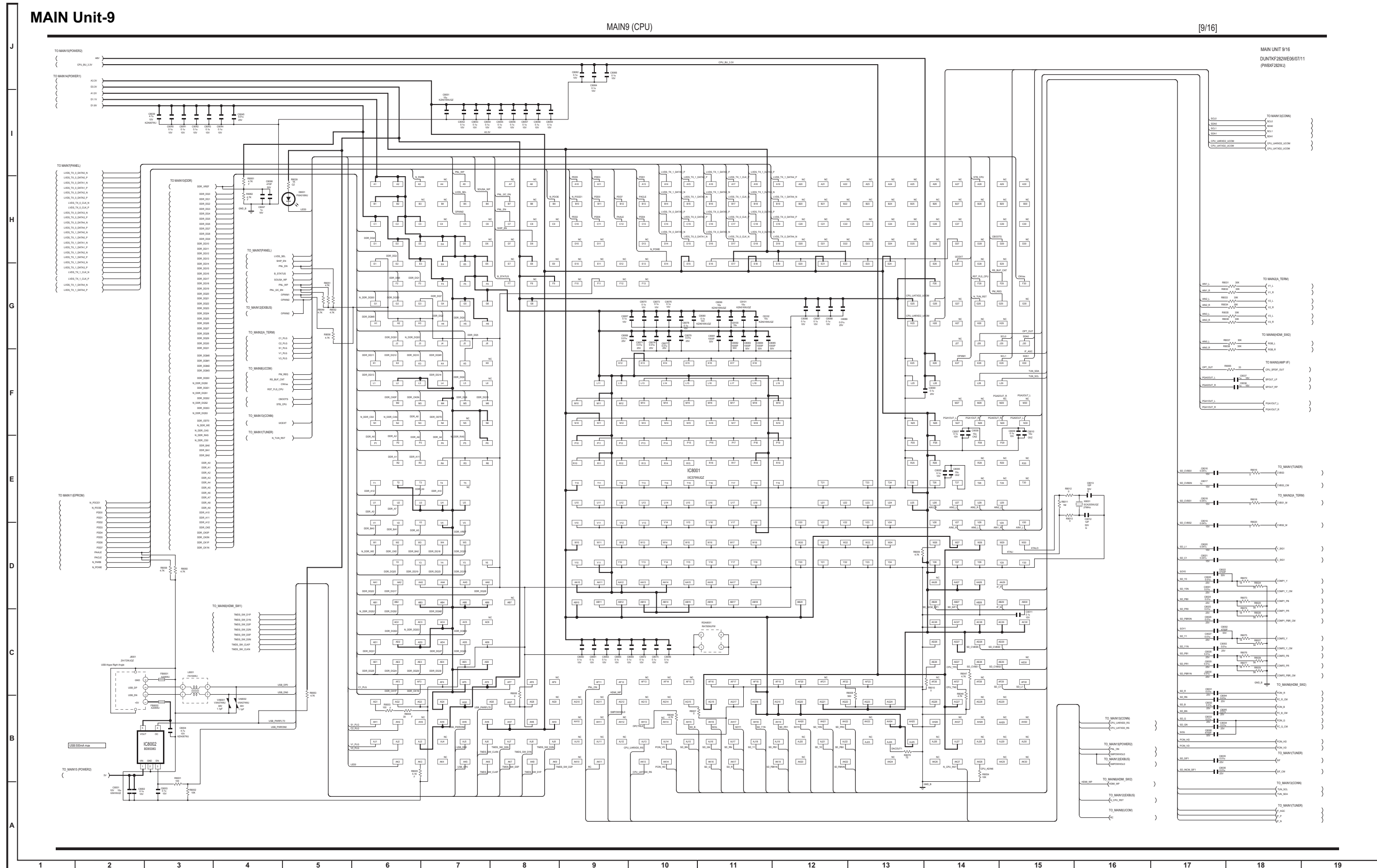

MAIN Unit-10

MAIN10 (DDR)

[10/16]

MAIN UNIT 10/16  
DUNTKF282WE06/07/11  
(PWBF282WJ)

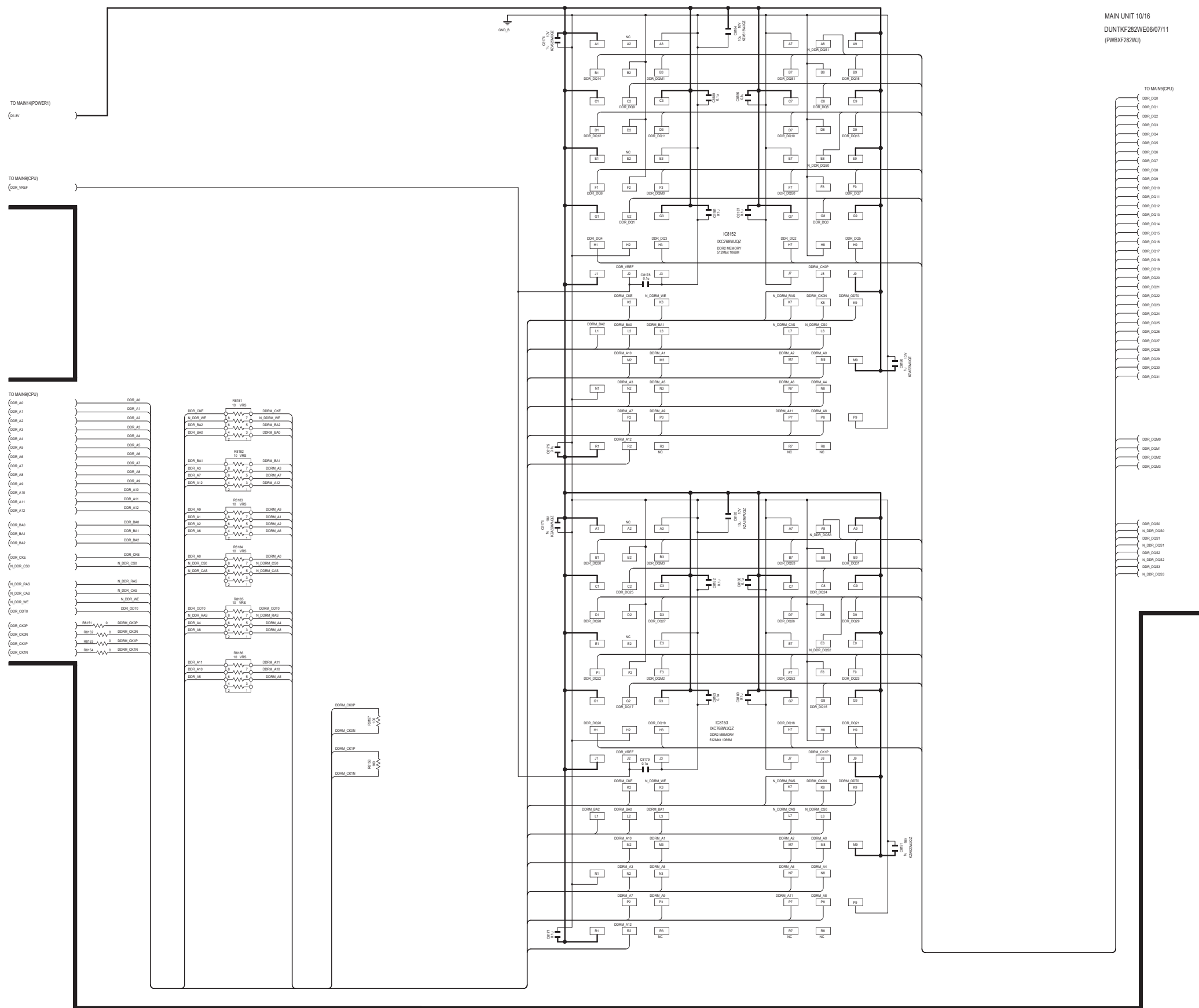

J  
I  
H  
G  
F  
E  
D  
C  
B  
A

1 2 3 4 5 6 7 8 9 10 11 12 13 14 15 16 17 18 19

MAIN Unit-11

MAIN11 (EPROM)

[11/16]

MAIN UNIT 11/16  
DUNTKF282WE06/07/11  
(PWBXF282WJ)

TO MAIN14(Power1)  
( D3.3V )

TO MAIN9(CPU)

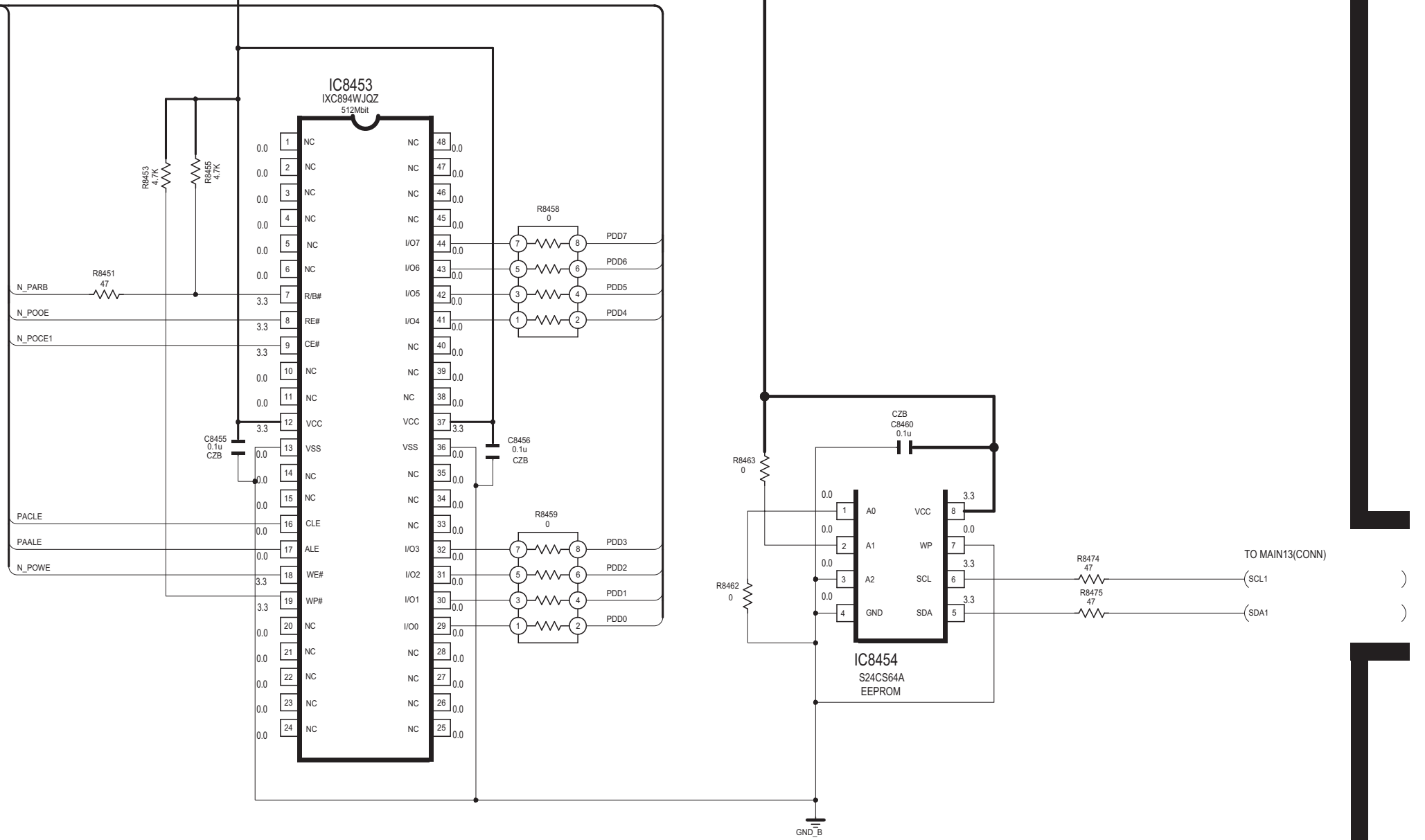
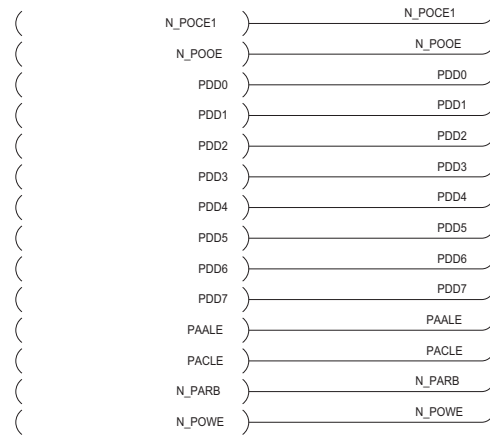

MAIN Unit-12

MAIN12 (EXBUS)

[12/16]

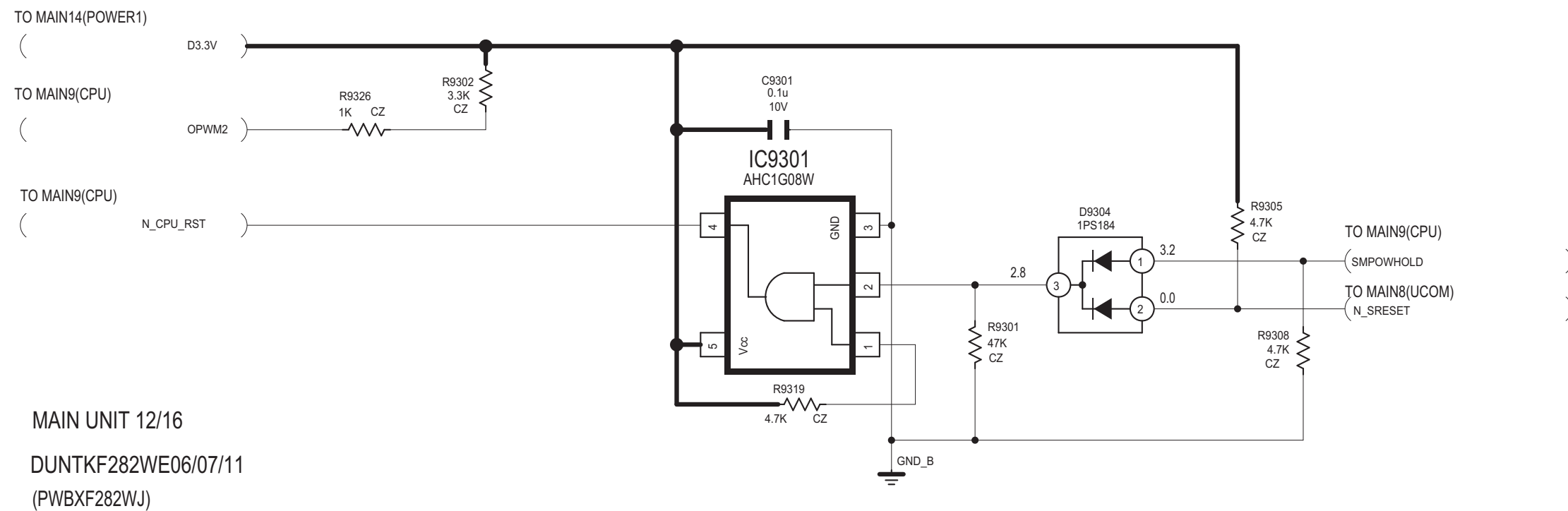

MAIN Unit-13

MAIN13 (CONN)

[13/16]

MAIN UNIT 13/16  
DUNTKF282WE06/07/11  
(PWBXF282WJ)

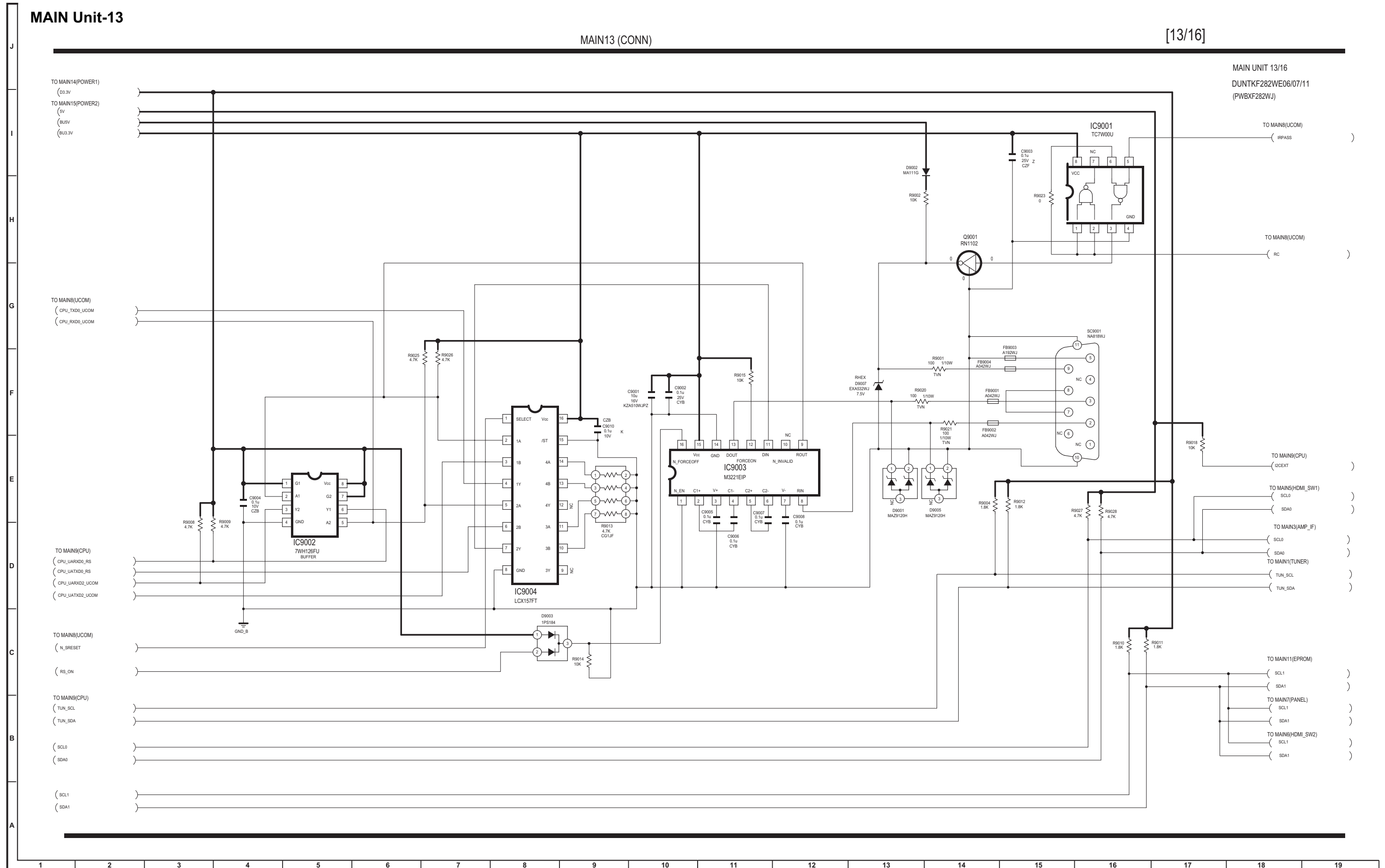

MAIN Unit-14

MAIN14 (POWER1)

[14/16]

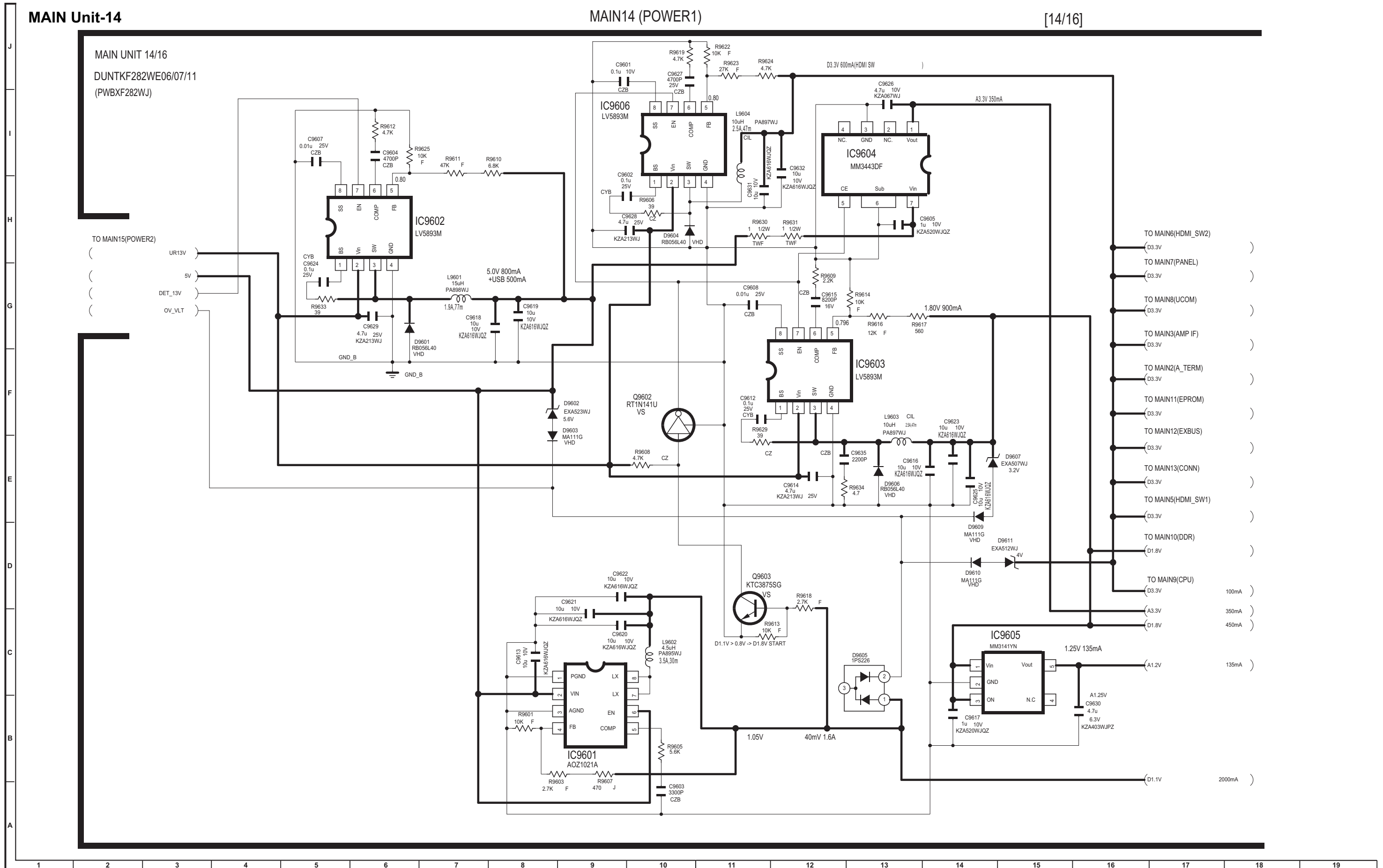

MAIN Unit-15

MAIN15 (POWER2)

[15/16]

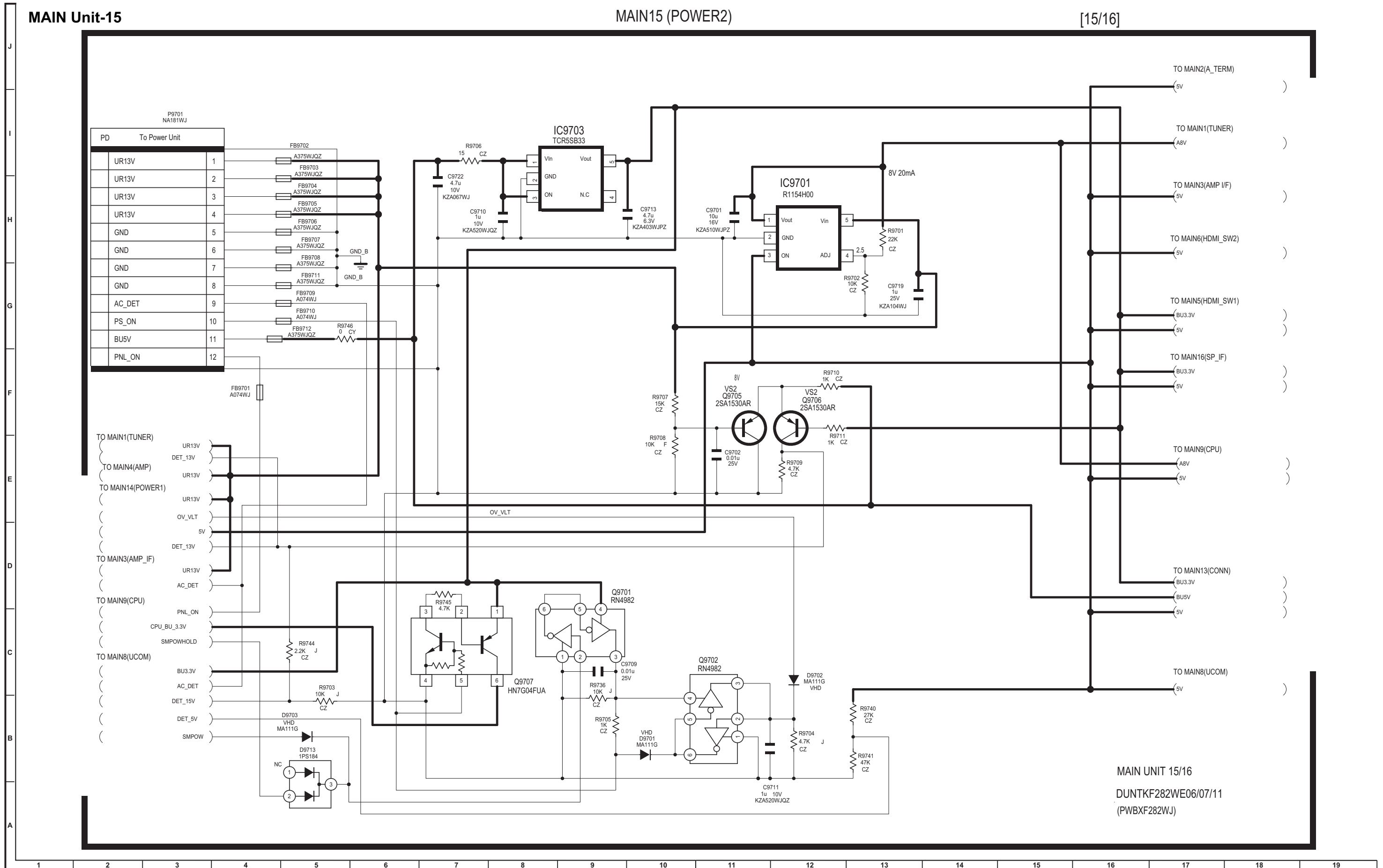

MAIN Unit-16

MAIN16 (SP\_IF)

[16/16]

MAIN UNIT 16/16

DUNTKF282WE06/07/11  
(PWBXF282WJ)

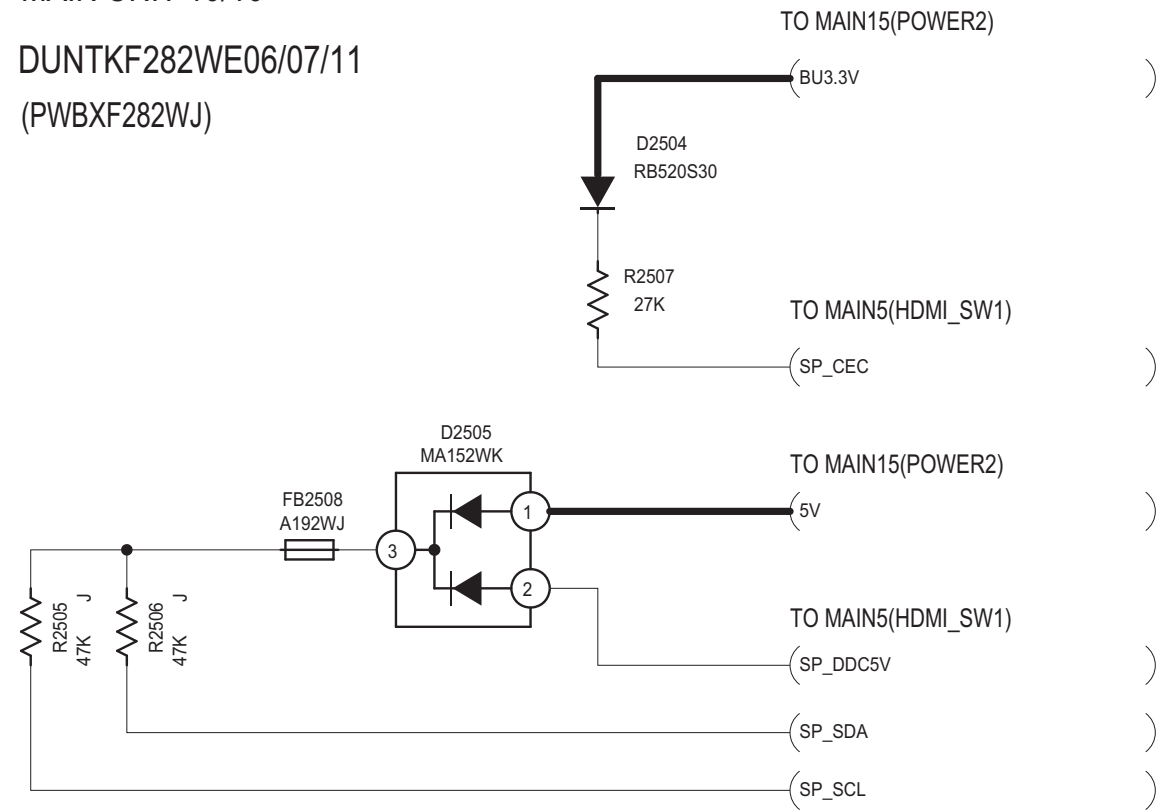

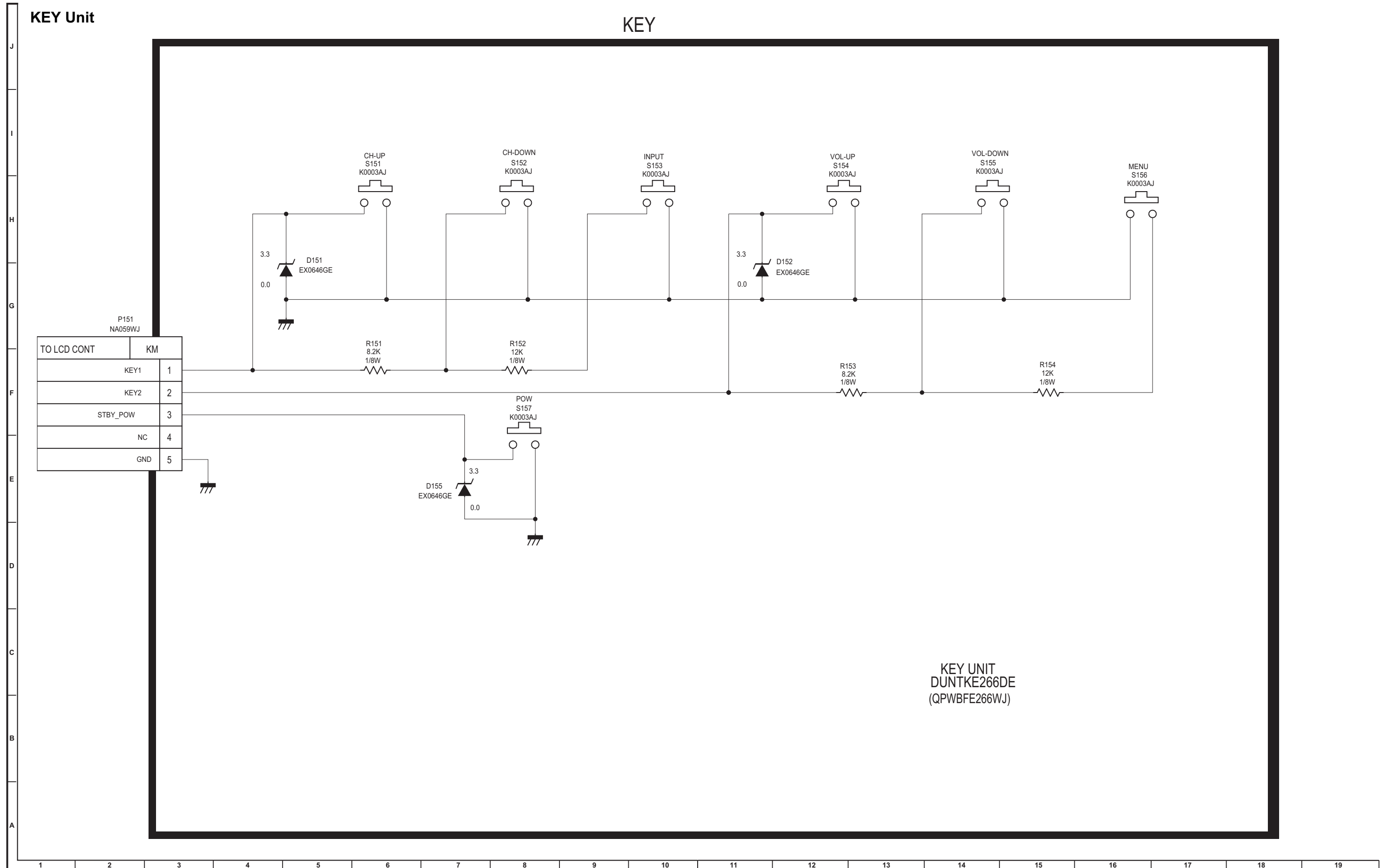

KEY UNIT  
DUNTKE266DE  
(QPWBFE266WJ)

R/C, LED Unit

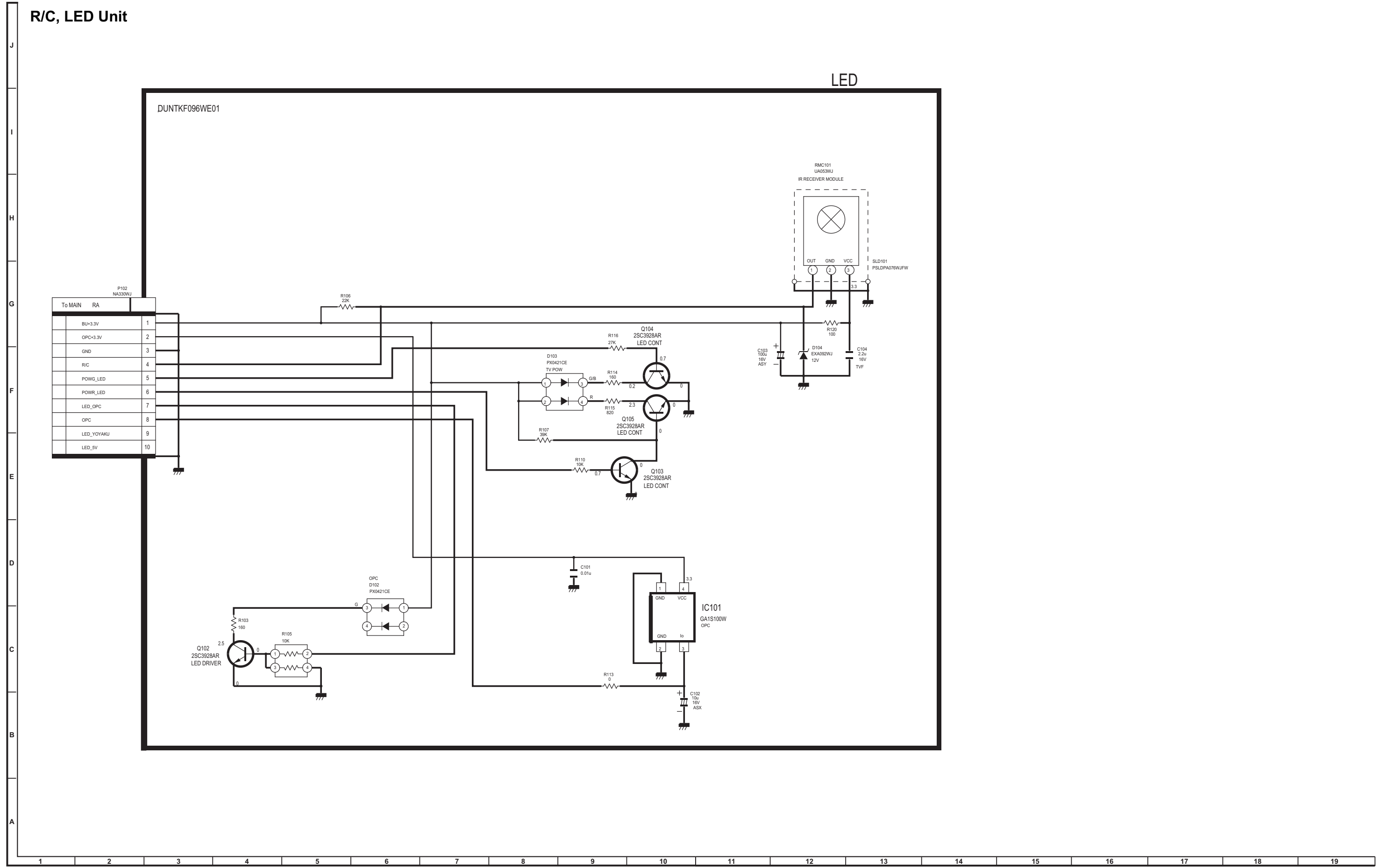



# SHARP PARTS GUIDE

No. S99C6LC60E77U



## LCD COLOR TELEVISION

**LC-60E77UN**  
**LC-65E77UM**  
**LC-C6077UN**  
**LC-C6577UM**

### MODELS

**Note:**

The reference numbers on the PWB are arranged in alphabetical order.

### CONTENTS

- |  |   |
|--|---|
| [1] PRINTED WIRING BOARD ASSEMBLIES (LC-60E77UN/C6077UN) | [8] LCD PANEL MODULE Assembly (LC-60E77UN/C6077UN)  |
| [2] PRINTED WIRING BOARD ASSEMBLIES (LC-65E77UM/C6577UM) | [9] CABINET PARTS (LC-65E77UM/C6577UM)              |
| [3] LCD PANEL  | [10] LCD PANEL MODULE Assembly (LC-65E77UM/C6577UM) |
| [4] DUNTKF282FM06/07/11 (MAIN Unit)                      | [11] SUPPLIED ACCESSORIES                           |
| [5] DUNTKF096FM01 (R/C, LED Unit)                        | [12] PACKING PARTS (NOT REPLACEMENT ITEM)           |
| [6] DUNTKE266FM02 (KEY Unit)                             | [13] SERVICE JIGS (USE FOR SERVICING)               |
| [7] CABINET PARTS (LC-60E77UN/C6077UN)                   |   |

Parts marked with "△" are important for maintaining the safety of the set. Be sure to replace these parts with specified ones for maintaining the safety and performance of the set.

NO.	PARTS CODE	PRICE RANK	NEW MARK	PART DELIVERY	DESCRIPTION
<b>[1] PRINTED WIRING BOARD ASSEMBLIES (LC-60E77UN/C6077UN)</b>					
N	DUNTKF282FM06	BT	N	X	MAIN Unit (LC-60E77UN)
N	DUNTKF282FM11		N	X	MAIN Unit (LC-C6077UN)
N	DUNTKF096FM01	AH		X	R/C, LED Unit
N	DUNTKE266FM02	AE		X	KEY Unit
N	RUNTK4225TPZZ	BL	N	X	LCD Control Unit
N	RUNTK4221TPZA	BN	N	X	FPGA Unit
N	RDENCA369WJQZ	BS	N	X	POWER Unit
N	RDENC2613TPZZ	BN		X	INVERTER-1 Unit
N	RDENC2615TPZZ	BN		X	INVERTER-2 Unit
<b>[2] PRINTED WIRING BOARD ASSEMBLIES (LC-65E77UM/C6577UM)</b>					
N	DUNTKF282FM07	BT	N	X	MAIN Unit (LC-65E77UM)
N	DUNTKF282FM11		N	X	MAIN Unit (LC-C6577UM)
N	DUNTKF096FM01	AH		X	R/C, LED Unit
N	DUNTKE266FM02	AE		X	KEY Unit
N	RDENCA324WJQZ	BL	N	X	MAIN POWER Unit
N	RDENCA323WJQZ	BN	N	X	SUB POWER Unit
N	CPWBX4137TPXA	BY		X	LCD Control Unit
N	RUNTKA335WJN1	BE		X	INVERTER-1 Unit
N	RUNTKA336WJN1	BB		X	INVERTER-2 Unit
N	RUNTKA337WJN1	BE		X	INVERTER-3 Unit
N	RUNTKA338WJN1	BE		X	INVERTER-4 Unit
N	RUNTKA339WJN1	BG		X	INVERTER-5 Unit
N	RUNTKA340WJN1	BE		X	INVERTER-6 Unit
<b>[3] LCD PANEL</b>					
N	R1LK600D3GW10Z	ER	N	X	60" LCD Panel Module Unit (LC-60E77UN/C6077UN)
N	R1LK645D3LW20Z	FK	N	X	65" LCD Panel Module Unit (LK645D3LW20Z) (LC-65E77UM/C6577UM)
<b>[4] DUNTKF282FM06/07/11 (MAIN Unit)</b>					
C501	VCKYCY1AB105KY	AB		J	Capacitor 1 10V Ceramic
C503	VCKYCY1AB105KY	AB		J	Capacitor 1 10V Ceramic
C504	VCCCCZ1HH150JY	AB		J	Capacitor 15p 50V Ceramic
C505	VCCCCZ1HH150JY	AB		J	Capacitor 15p 50V Ceramic
C506	VCCCCZ1HH150JY	AB		J	Capacitor 15p 50V Ceramic
C507	VCCCCZ1HH150JY	AB		J	Capacitor 15p 50V Ceramic
C508	VCCCCZ1HH150JY	AB		J	Capacitor 15p 50V Ceramic
C509	VCCCCZ1HH150JY	AB		J	Capacitor 15p 50V Ceramic
C510	VCCCCZ1HH150JY	AB		J	Capacitor 15p 50V Ceramic
C512	VCCCCZ1HH150JY	AB		J	Capacitor 15p 50V Ceramic
C514	VCCCCZ1HH150JY	AB		J	Capacitor 15p 50V Ceramic
C515	VCCCCZ1HH150JY	AB		J	Capacitor 15p 50V Ceramic
C516	VCCCCZ1HH150JY	AB		J	Capacitor 15p 50V Ceramic
C517	VCCCCZ1HH150JY	AB		J	Capacitor 15p 50V Ceramic
C519	VCCCCZ1HH150JY	AB		J	Capacitor 15p 50V Ceramic
C520	VCCCCZ1HH150JY	AB		J	Capacitor 15p 50V Ceramic
C521	VCCCCZ1HH150JY	AB		J	Capacitor 15p 50V Ceramic
C522	VCCCCZ1HH150JY	AB		J	Capacitor 15p 50V Ceramic
C523	VCCCCZ1HH150JY	AB		J	Capacitor 15p 50V Ceramic
C525	VCCCCZ1HH150JY	AB		J	Capacitor 15p 50V Ceramic
C533	VCCCCZ1HH471JY	AA		J	Capacitor 470p 50V Ceramic
C535	VCKYCY1AB105KY	AB		J	Capacitor 1 10V Ceramic
C536	VCCCCZ1HH471JY	AA		J	Capacitor 470p 50V Ceramic
C537	VCCCCZ1HH471JY	AA		J	Capacitor 470p 50V Ceramic
C539	VCCCCZ1HH471JY	AA		J	Capacitor 470p 50V Ceramic
C540	VCKYCY1AB105KY	AB		J	Capacitor 1 10V Ceramic
C555	VCKYCY1AB105KY	AB		J	Capacitor 1 10V Ceramic
C557	VCKYCY1AB105KY	AB		J	Capacitor 1 10V Ceramic
C563	VCKYCY1EB103KY	AA		J	Capacitor 0.01 25V Ceramic
C565	VCKYCY1EF104ZY	AA		J	Capacitor 0.1 25V Ceramic
C566	RC-KZA403WJPZY	AB		J	Capacitor 4.7 6.3V Ceramic
C569	VCKYCY1AB105KY	AB		J	Capacitor 1 10V Ceramic
C570	VCKYCY1AB105KY	AB		J	Capacitor 1 10V Ceramic
C575	VCCCCZ1HH150JY	AB		J	Capacitor 15p 50V Ceramic
C576	VCCCCZ1HH150JY	AB		J	Capacitor 15p 50V Ceramic
C577	VCCCCZ1HH150JY	AB		J	Capacitor 15p 50V Ceramic
C578	VCCCCZ1HH150JY	AB		J	Capacitor 15p 50V Ceramic
C579	VCCCCZ1HH150JY	AB		J	Capacitor 15p 50V Ceramic
C580	VCCCCZ1HH150JY	AB		J	Capacitor 15p 50V Ceramic
C581	RC-KZA616WJQZY	AB		J	Capacitor 10 10V Ceramic
C1107	VCKYCY1HB102KY	AB		J	Capacitor 1000p 50V Ceramic
C1112	RC-KZA510WJPZY	AB		J	Capacitor 10 16V Ceramic
C1113	VCKYCY1EB103KY	AA		J	Capacitor 0.01 25V Ceramic
C1114	RC-KZA520WJQZY	AA		J	Capacitor 1 10V Ceramic
C1116	VCKYCY1EB103KY	AA		J	Capacitor 0.01 25V Ceramic
C1118	VCKYCY1HB102KY	AB		J	Capacitor 1000p 50V Ceramic
C1119	VCKYCY1AB473KY	AB		J	Capacitor 0.047 10V Ceramic
C1120	RC-KZA520WJQZY	AA		J	Capacitor 1 10V Ceramic
C1121	RC-KZA520WJQZY	AA		J	Capacitor 1 10V Ceramic
C1123	RC-KZA520WJQZY	AA		J	Capacitor 1 10V Ceramic
C1126	VCKYCY1HB222KY	AB		J	Capacitor 2200p 50V Ceramic
C1129	VCKYCY1EB103KY	AA		J	Capacitor 0.01 25V Ceramic
C1130	VCKYCY1EB103KY	AA		J	Capacitor 0.01 25V Ceramic
C1132	RC-KZA616WJQZY	AB		J	Capacitor 10 10V Ceramic

NO.	PARTS CODE	PRICE RANK	NEW MARK	PART DELIVERY	DESCRIPTION
<b>[4] DUNTKF282FM06/07/11 (MAIN Unit)</b>					
C1137	VCKYCZ1HB222KY	AB		J	Capacitor 2200p 50V Ceramic
C1138	RC-KZA520WJQZY	AA		J	Capacitor 1 10V Ceramic
C1141	VCKYCZ1HB102KY	AB		J	Capacitor 1000p 50V Ceramic
C1142	VCKYCZ1HB102KY	AB		J	Capacitor 1000p 50V Ceramic
C1143	VCKYCZ1HB102KY	AB		J	Capacitor 1000p 50V Ceramic
C1144	VCKYCZ1EB103KY	AA		J	Capacitor 0.01 25V Ceramic
C1145	VCKYCY1EB104KY	AB		J	Capacitor 0.1 25V Ceramic
C1146	VCKYCZ1EB103KY	AA		J	Capacitor 0.01 25V Ceramic
C1147	VCKYCY1EB104KY	AB		J	Capacitor 0.1 25V Ceramic
C1148	VCKYCZ1EB472KY	AB		J	Capacitor 4700p 25V Ceramic
C1149	VCKYCZ1EB472KY	AB		J	Capacitor 4700p 25V Ceramic
C1150	RC-KZA616WJQZY	AB		J	Capacitor 10 10V Ceramic
C1151	RC-KZA616WJQZY	AB		J	Capacitor 10 10V Ceramic
C1152	RC-KZA616WJQZY	AB		J	Capacitor 10 10V Ceramic
C1153	RC-KZA616WJQZY	AB		J	Capacitor 10 10V Ceramic
C1154	RC-KZA213WJZZY	AC		J	Capacitor 4.7 25V Ceramic
C1155	VCKYCZ1EB103KY	AA		J	Capacitor 0.01 25V Ceramic
C1159	VCCCCZ1HH470JY	AB		J	Capacitor 47p 50V Ceramic
C1160	VCCCCZ1HH470JY	AB		J	Capacitor 47p 50V Ceramic
C1301	VCKYCZ1EF104ZY	AA		J	Capacitor 0.1 25V Ceramic
C1303	RC-KZA616WJQZY	AB		J	Capacitor 10 10V Ceramic
C1306	VCKYTV1CB105KY	AC		J	Capacitor 1 16V Ceramic
C1307	VCKYTV1CB105KY	AC		J	Capacitor 1 16V Ceramic
C1309	RC-KZA616WJQZY	AB		J	Capacitor 10 10V Ceramic
C1310	VCKYCZ1EF104ZY	AA		J	Capacitor 0.1 25V Ceramic
C1311	RC-KZA616WJQZY	AB		J	Capacitor 10 10V Ceramic
C1312	VCKYCZ1EF104ZY	AA		J	Capacitor 0.1 25V Ceramic
C1314	RC-KZA098WJZZY	AD		J	Capacitor 10 25V Ceramic
C1602	VCKYCZ1AB104KY	AB		J	Capacitor 0.1 10V Ceramic
C1613	RC-KZA616WJQZY	AB		J	Capacitor 10 10V Ceramic
C1614	VCKYCZ1AB104KY	AB		J	Capacitor 0.1 10V Ceramic
C1615	VCKYCZ1HB102KY	AB		J	Capacitor 1000p 50V Ceramic
C1616	RC-KZA616WJQZY	AB		J	Capacitor 10 10V Ceramic
C1617	VCKYCZ1AB104KY	AB		J	Capacitor 0.1 10V Ceramic
C1618	VCKYCZ1AB104KY	AB		J	Capacitor 0.1 10V Ceramic
C1619	VCKYCZ1HB102KY	AB		J	Capacitor 1000p 50V Ceramic
C1620	VCKYCZ1HB102KY	AB		J	Capacitor 1000p 50V Ceramic
C1623	VCKYCZ1AB104KY	AB		J	Capacitor 0.1 10V Ceramic
C1624	VCKYCZ1AB104KY	AB		J	Capacitor 0.1 10V Ceramic
C1625	RC-KZA520WJQZY	AA		J	Capacitor 1 10V Ceramic
C1626	RC-KZA520WJQZY	AA		J	Capacitor 1 10V Ceramic
C1627	RC-KZA520WJQZY	AA		J	Capacitor 1 10V Ceramic
C1628	RC-KZA520WJQZY	AA		J	Capacitor 1 10V Ceramic
C1629	RC-KZA520WJQZY	AA		J	Capacitor 1 10V Ceramic
C1634	RC-KZA616WJQZY	AB		J	Capacitor 10 10V Ceramic
C1801	RC-KZA616WJQZY	AB		J	Capacitor 10 10V Ceramic
C1802	VCKYCZ1AB104KY	AB		J	Capacitor 0.1 10V Ceramic
C1803	VCKYCZ1HB102KY	AB		J	Capacitor 1000p 50V Ceramic
C1804	RC-KZA616WJQZY	AB		J	Capacitor 10 10V Ceramic
C1809	VCKYCY1AB105KY	AB		J	Capacitor 1 10V Ceramic
C1810	VCKYCY1AB105KY	AB		J	Capacitor 1 10V Ceramic
C1811	VCCCCZ1HH470JY	AB		J	Capacitor 47p 50V Ceramic
C1812	VCCCCZ1HH470JY	AB		J	Capacitor 47p 50V Ceramic
C1814	VCKYCZ1AB104KY	AB		J	Capacitor 0.1 10V Ceramic
C1825	VCKYCZ1AB104KY	AB		J	Capacitor 0.1 10V Ceramic
C1826	VCKYCZ1AB104KY	AB		J	Capacitor 0.1 10V Ceramic
C1827	VCKYCZ1HB102KY	AB		J	Capacitor 1000p 50V Ceramic
C1828	VCKYCZ1HB102KY	AB		J	Capacitor 1000p 50V Ceramic
C1835	RC-KZA520WJQZY	AA		J	Capacitor 1 10V Ceramic
C1837	RC-KZA520WJQZY	AA		J	Capacitor 1 10V Ceramic
C1842	RC-KZA520WJQZY	AA		J	Capacitor 1 10V Ceramic
C1849	RC-KZA616WJQZY	AB		J	Capacitor 10 10V Ceramic
C1850	VCKYCZ1EB103KY	AA		J	Capacitor 0.01 25V Ceramic
C1852	RC-KZA616WJQZY	AB		J	Capacitor 10 10V Ceramic
C2002	VCKYCZ1HB152KY	AB		J	Capacitor 1500p 50V Ceramic
C2003	VCKYCZ1AB104KY	AB		J	Capacitor 0.1 10V Ceramic
C2008	VCKYCZ1AB104KY	AB		J	Capacitor 0.1 10V Ceramic
C2010	VCKYCZ1AB104KY	AB		J	Capacitor 0.1 10V Ceramic
C2012	VCKYCZ1AB104KY	AB		J	Capacitor 0.1 10V Ceramic
C2016	VCKYCZ1AB104KY	AB		J	Capacitor 0.1 10V Ceramic
C2020	VCKYCZ1HB102KY	AB		J	Capacitor 1000p 50V Ceramic
C2024	VCKYCZ1AB104KY	AB		J	Capacitor 0.1 10V Ceramic
C2026	VCKYCZ1AB104KY	AB		J	Capacitor 0.1 10V Ceramic
C2027	VCCCCZ1HH101JY	AB		J	Capacitor 100p 50V Ceramic
C2028	VCCCCZ1HH101JY	AB		J	Capacitor 100p 50V Ceramic
C2029	VCCCCZ1HH101JY	AB		J	Capacitor 100p 50V Ceramic
C2030	RC-KZA616WJQZY	AB		J	Capacitor 10 10V Ceramic
C2602	VCKYCZ1AB104KY	AB		J	Capacitor 0.1 10V Ceramic
C2606	VCKYCZ1AB104KY	AB		J	Capacitor 0.1 10V Ceramic
C2607	VCKYCZ1AB104KY	AB		J	Capacitor 0.1 10V Ceramic
C2704	RC-KZA114WJZZY	AB		J	Capacitor 1 25V Ceramic
C2705	RC-KZA114WJZZY	AB		J	Capacitor 1 25V Ceramic
C2706	RC-KZA114WJZZY	AB		J	Capacitor 1 25V Ceramic
C2707	RC-KZA114WJZZY	AB		J	Capacitor 1 25V Ceramic
C2710	VCERMZ1EN477MY	AE		J	Capacitor 470 25V Capacitor(AL)

NO.	PARTS CODE	PRICE RANK	NEW MARK	PART DELIVERY	DESCRIPTION
<b>[4] DUNTKF282FM06/07/11 (MAIN Unit)</b>					
C2711	VCKYCZ1EF104ZY	AA		J	Capacitor 0.1 25V Ceramic
C2712	RC-KZA616WJQZY	AB		J	Capacitor 10 10V Ceramic
C2713	VCKYCZ1EF104ZY	AA		J	Capacitor 0.1 25V Ceramic
C2716	RC-KZA114WJZZY	AB		J	Capacitor 1 25V Ceramic
C2717	RC-KZA114WJZZY	AB		J	Capacitor 1 25V Ceramic
C2723	RC-KZA114WJZZY	AB		J	Capacitor 1 25V Ceramic
C2724	RC-KZA114WJZZY	AB		J	Capacitor 1 25V Ceramic
C2725	VCKYCY1EB104KY	AB		J	Capacitor 0.1 25V Ceramic
C2726	VCKYCY1EB104KY	AB		J	Capacitor 0.1 25V Ceramic
C2727	VCKYCY1EB104KY	AB		J	Capacitor 0.1 25V Ceramic
C2728	VCKYCY1EB104KY	AB		J	Capacitor 0.1 25V Ceramic
C2730	VCKYTV1EB224KY	AA		J	Capacitor 0.22 25V Ceramic
C2731	VCKYTV1EB224KY	AA		J	Capacitor 0.22 25V Ceramic
C2737	VCCCZ1HH151JY	AB		J	Capacitor 150p 50V Ceramic
C2738	VCCCZ1HH151JY	AB		J	Capacitor 150p 50V Ceramic
C2740	VCCCZ1HH151JY	AB		J	Capacitor 150p 50V Ceramic
C2741	VCCCZ1HH151JY	AB		J	Capacitor 150p 50V Ceramic
C2748	VCCCZ1HH101JY	AB		J	Capacitor 100p 50V Ceramic
C8001	RC-KZA616WJQZY	AB		J	Capacitor 10 10V Ceramic
C8002	VCKYCZ1AB104KY	AB		J	Capacitor 0.1 10V Ceramic
C8003	VCKYCZ1AB104KY	AB		J	Capacitor 0.1 10V Ceramic
C8004	RC-KZA067WJZZY	AB		J	Capacitor 4.7 10V Ceramic
C8005	VCKYCZ1AB104KY	AB		J	Capacitor 0.1 10V Ceramic
C8006	RC-KZA616WJQZY	AB		J	Capacitor 10 10V Ceramic
C8007	VCKYCZ1AB104KY	AB		J	Capacitor 0.1 10V Ceramic
C8008	RC-KZA616WJQZY	AB		J	Capacitor 10 10V Ceramic
C8009	VCKYCZ1AB104KY	AB		J	Capacitor 0.1 10V Ceramic
C8010	RC-KZA616WJQZY	AB		J	Capacitor 10 10V Ceramic
C8011	VCKYCZ1AB104KY	AB		J	Capacitor 0.1 10V Ceramic
C8012	VCCCZ1HH120GY	AA		J	Capacitor 12p 50V Ceramic
C8013	VCCCZ1HH100DY	AB		J	Capacitor 10p 50V Ceramic
C8016	VCKYCZ1AB473KY	AB		J	Capacitor 0.047 10V Ceramic
C8017	RC-KZA531WJQZY	AA		J	Capacitor 1 10V Ceramic
C8018	VCKYCZ1AB473KY	AB		J	Capacitor 0.047 10V Ceramic
C8019	VCKYCZ1AB473KY	AB		J	Capacitor 0.047 10V Ceramic
C8020	VCKYCZ1AB473KY	AB		J	Capacitor 0.047 10V Ceramic
C8021	VCKYCZ1AB473KY	AB		J	Capacitor 0.047 10V Ceramic
C8022	VCKYCZ1HB472KY	AA		J	Capacitor 4700p 50V Ceramic
C8023	VCKYCZ1EB103KY	AA		J	Capacitor 0.01 25V Ceramic
C8024	VCKYCZ1EB103KY	AA		J	Capacitor 0.01 25V Ceramic
C8025	VCKYCZ1EB103KY	AA		J	Capacitor 0.01 25V Ceramic
C8026	VCKYCZ1EB103KY	AA		J	Capacitor 0.01 25V Ceramic
C8027	VCKYCZ1EB103KY	AA		J	Capacitor 0.01 25V Ceramic
C8028	VCKYCZ1EB103KY	AA		J	Capacitor 0.01 25V Ceramic
C8029	VCKYCZ1EB103KY	AA		J	Capacitor 0.01 25V Ceramic
C8030	VCKYCZ1EB103KY	AA		J	Capacitor 0.01 25V Ceramic
C8031	VCKYCZ1EB103KY	AA		J	Capacitor 0.01 25V Ceramic
C8032	VCKYCZ1EB103KY	AA		J	Capacitor 0.01 25V Ceramic
C8033	VCKYCZ1EB103KY	AA		J	Capacitor 0.01 25V Ceramic
C8034	VCKYCZ1EB103KY	AA		J	Capacitor 0.01 25V Ceramic
C8035	VCKYCZ1EB103KY	AA		J	Capacitor 0.01 25V Ceramic
C8036	VCKYCZ1EB103KY	AA		J	Capacitor 0.01 25V Ceramic
C8037	VCKYTV1CB105KY	AC		J	Capacitor 1 16V Ceramic
C8038	VCKYTV1CB105KY	AC		J	Capacitor 1 16V Ceramic
C8039	RC-KZA067WJZZY	AB		J	Capacitor 4.7 10V Ceramic
C8040	VCKYCZ1AB104KY	AB		J	Capacitor 0.1 10V Ceramic
C8041	VCKYCZ1AB104KY	AB		J	Capacitor 0.1 10V Ceramic
C8042	VCKYCZ1AB104KY	AB		J	Capacitor 0.1 10V Ceramic
C8043	VCKYCZ1AB104KY	AB		J	Capacitor 0.1 10V Ceramic
C8044	VCKYCZ1AB104KY	AB		J	Capacitor 0.1 10V Ceramic
C8045	VCKYCZ1EB103KY	AA		J	Capacitor 0.01 25V Ceramic
C8046	VCKYCZ1AB104KY	AB		J	Capacitor 0.1 10V Ceramic
C8051	RC-KZA616WJQZY	AB		J	Capacitor 10 10V Ceramic
C8052	VCKYCZ1AB104KY	AB		J	Capacitor 0.1 10V Ceramic
C8053	VCKYCZ1AB104KY	AB		J	Capacitor 0.1 10V Ceramic
C8054	VCKYCZ1AB104KY	AB		J	Capacitor 0.1 10V Ceramic
C8055	VCKYCZ1AB104KY	AB		J	Capacitor 0.1 10V Ceramic
C8056	VCKYCZ1AB104KY	AB		J	Capacitor 0.1 10V Ceramic
C8057	VCKYCZ1AB104KY	AB		J	Capacitor 0.1 10V Ceramic
C8058	VCKYCZ1AB104KY	AB		J	Capacitor 0.1 10V Ceramic
C8059	VCKYCZ1AB104KY	AB		J	Capacitor 0.1 10V Ceramic
C8060	VCKYCZ1AB104KY	AB		J	Capacitor 0.1 10V Ceramic
C8061	VCKYCZ1AB104KY	AB		J	Capacitor 0.1 10V Ceramic
C8062	VCKYCZ1AB104KY	AB		J	Capacitor 0.1 10V Ceramic
C8063	VCKYCZ1AB104KY	AB		J	Capacitor 0.1 10V Ceramic
C8064	VCKYCZ1AB104KY	AB		J	Capacitor 0.1 10V Ceramic
C8065	VCKYCZ1AB104KY	AB		J	Capacitor 0.1 10V Ceramic
C8066	VCKYCZ1AB104KY	AB		J	Capacitor 0.1 10V Ceramic
C8067	VCKYCZ1AB104KY	AB		J	Capacitor 0.1 10V Ceramic
C8068	VCKYCZ1EB103KY	AA		J	Capacitor 0.01 25V Ceramic
C8069	VCKYCZ1AB104KY	AB		J	Capacitor 0.1 10V Ceramic
C8070	VCKYCZ1AB104KY	AB		J	Capacitor 0.1 10V Ceramic
C8071	VCKYCZ1EB103KY	AA		J	Capacitor 0.01 25V Ceramic
C8072	VCKYCZ1AB104KY	AB		J	Capacitor 0.1 10V Ceramic
C8073	VCKYCZ1AB104KY	AB		J	Capacitor 0.1 10V Ceramic

NO.	PARTS CODE	PRICE RANK	NEW MARK	PART DELIVERY	DESCRIPTION
<b>[4] DUNTKF282FM06/07/11 (MAIN Unit)</b>					
C8074	VCKYCZ1EB103KY	AA		J	Capacitor 0.01 25V Ceramic
C8075	VCKYCZ1AB104KY	AB		J	Capacitor 0.1 10V Ceramic
C8076	VCKYCZ1AB104KY	AB		J	Capacitor 0.1 10V Ceramic
C8077	VCKYCZ1EB103KY	AA		J	Capacitor 0.01 25V Ceramic
C8078	VCKYCZ1AB104KY	AB		J	Capacitor 0.1 10V Ceramic
C8079	VCKYCZ1EB103KY	AA		J	Capacitor 0.01 25V Ceramic
C8080	VCKYCZ1AB104KY	AB		J	Capacitor 0.1 10V Ceramic
C8081	VCKYCZ1HB102KY	AB		J	Capacitor 1000p 50V Ceramic
C8082	VCKYCZ1HB102KY	AB		J	Capacitor 1000p 50V Ceramic
C8083	VCKYCZ1HB102KY	AB		J	Capacitor 1000p 50V Ceramic
C8084	VCKYCZ1HB102KY	AB		J	Capacitor 1000p 50V Ceramic
C8085	VCKYCZ1HB102KY	AB		J	Capacitor 1000p 50V Ceramic
C8086	VCKYCZ1AB104KY	AB		J	Capacitor 0.1 10V Ceramic
C8087	VCKYCZ1AB104KY	AB		J	Capacitor 0.1 10V Ceramic
C8088	VCKYCZ1AB104KY	AB		J	Capacitor 0.1 10V Ceramic
C8089	VCKYCZ1EB103KY	AA		J	Capacitor 0.01 25V Ceramic
C8090	VCKYCZ1EF104ZY	AA		J	Capacitor 0.1 25V Ceramic
C8091	VCKYCZ1EB103KY	AA		J	Capacitor 0.01 25V Ceramic
C8092	VCKYCZ1HB472KY	AA		J	Capacitor 4700p 50V Ceramic
C8093	VCKYCZ1EB103KY	AA		J	Capacitor 0.01 25V Ceramic
C8094	VCKYCZ1EB103KY	AA		J	Capacitor 0.01 25V Ceramic
C8095	VCKYCZ1EB103KY	AA		J	Capacitor 0.01 25V Ceramic
C8096	VCKYCZ1HB472KY	AA		J	Capacitor 4700p 50V Ceramic
C8097	VCKYTV1CB105KY	AC		J	Capacitor 1 16V Ceramic
C8098	VCKYCZ1HB471KY	AB		J	Capacitor 470p 50V Ceramic
C8099	RC-KZA616WJQZY	AB		J	Capacitor 10 10V Ceramic
C8100	RC-KZA616WJQZY	AB		J	Capacitor 10 10V Ceramic
C8101	RC-KZA616WJQZY	AB		J	Capacitor 10 10V Ceramic
C8102	RC-KZA616WJQZY	AB		J	Capacitor 10 10V Ceramic
C8174	RC-KZA520WJQZY	AA		J	Capacitor 1 10V Ceramic
C8175	VCKYCZ1AB104KY	AB		J	Capacitor 0.1 10V Ceramic
C8176	RC-KZA520WJQZY	AA		J	Capacitor 1 10V Ceramic
C8177	VCKYCZ1AB104KY	AB		J	Capacitor 0.1 10V Ceramic
C8178	VCKYCZ1AB104KY	AB		J	Capacitor 0.1 10V Ceramic
C8179	VCKYCZ1AB104KY	AB		J	Capacitor 0.1 10V Ceramic
C8180	VCKYCZ1AB104KY	AB		J	Capacitor 0.1 10V Ceramic
C8181	VCKYCZ1AB104KY	AB		J	Capacitor 0.1 10V Ceramic
C8182	VCKYCZ1AB104KY	AB		J	Capacitor 0.1 10V Ceramic
C8183	VCKYCZ1AB104KY	AB		J	Capacitor 0.1 10V Ceramic
C8184	RC-KZA616WJQZY	AB		J	Capacitor 10 10V Ceramic
C8185	RC-KZA616WJQZY	AB		J	Capacitor 10 10V Ceramic
C8186	VCKYCZ1AB104KY	AB		J	Capacitor 0.1 10V Ceramic
C8187	VCKYCZ1AB104KY	AB		J	Capacitor 0.1 10V Ceramic
C8188	VCKYCZ1AB104KY	AB		J	Capacitor 0.1 10V Ceramic
C8189	VCKYCZ1AB104KY	AB		J	Capacitor 0.1 10V Ceramic
C8190	RC-KZA520WJQZY	AA		J	Capacitor 1 10V Ceramic
C8191	RC-KZA520WJQZY	AA		J	Capacitor 1 10V Ceramic
C8455	VCKYCZ1AB104KY	AB		J	Capacitor 0.1 10V Ceramic
C8456	VCKYCZ1AB104KY	AB		J	Capacitor 0.1 10V Ceramic
C8460	VCKYCZ1AB104KY	AB		J	Capacitor 0.1 10V Ceramic
C9001	RC-KZA510WJQZY	AB		J	Capacitor 10 16V Ceramic
C9002	VCKYCY1EB104KY	AB		J	Capacitor 0.1 25V Ceramic
C9003	VCKYCZ1EF104ZY	AA		J	Capacitor 0.1 25V Ceramic
C9004	VCKYCZ1AB104KY	AB		J	Capacitor 0.1 10V Ceramic
C9005	VCKYCY1EB104KY	AB		J	Capacitor 0.1 25V Ceramic
C9006	VCKYCY1EB104KY	AB		J	Capacitor 0.1 25V Ceramic
C9007	VCKYCY1EB104KY	AB		J	Capacitor 0.1 25V Ceramic
C9008	VCKYCY1EB104KY	AB		J	Capacitor 0.1 25V Ceramic
C9010	VCKYCZ1AB104KY	AB		J	Capacitor 0.1 10V Ceramic
C9301	VCKYCZ1AB104KY	AB		J	Capacitor 0.1 10V Ceramic
C9601	VCKYCZ1AB104KY	AB		J	Capacitor 0.1 10V Ceramic
C9602	VCKYCY1EB104KY	AB		J	Capacitor 0.1 25V Ceramic
C9603	VCKYCZ1HB332KY	AA		J	Capacitor 3300p 50V Ceramic
C9604	VCKYCZ1EB472KY	AB		J	Capacitor 4700p 25V Ceramic
C9605	RC-KZA520WJQZY	AA		J	Capacitor 1 10V Ceramic
C9607	VCKYCZ1EB103KY	AA		J	Capacitor 0.01 25V Ceramic
C9608	VCKYCZ1EB103KY	AA		J	Capacitor 0.01 25V Ceramic
C9612	VCKYCY1EB104KY	AB		J	Capacitor 0.1 25V Ceramic
C9613	RC-KZA616WJQZY	AB		J	Capacitor 10 10V Ceramic
C9614	RC-KZA213WJZZY	AC		J	Capacitor 4.7 25V Ceramic
C9615	VCKYCZ1CB822KY	AB		J	Capacitor 8200p 16V Ceramic
C9616	RC-KZA616WJQZY	AB		J	Capacitor 10 10V Ceramic
C9617	RC-KZA520WJQZY	AA		J	Capacitor 1 10V Ceramic
C9618	RC-KZA616WJQZY	AB		J	Capacitor 10 10V Ceramic
C9619	RC-KZA616WJQZY	AB		J	Capacitor 10 10V Ceramic
C9620	RC-KZA616WJQZY	AB		J	Capacitor 10 10V Ceramic
C9621	RC-KZA616WJQZY	AB		J	Capacitor 10 10V Ceramic
C9622	RC-KZA616WJQZY	AB		J	Capacitor 10 10V Ceramic
C9623	RC-KZA616WJQZY	AB		J	Capacitor 10 10V Ceramic
C9624	VCKYCY1EB104KY	AB		J	Capacitor 0.1 25V Ceramic
C9625	RC-KZA616WJQZY	AB		J	Capacitor 10 10V Ceramic
C9626	RC-KZA067WJZZY	AB		J	Capacitor 4.7 10V Ceramic
C9627	VCKYCZ1EB472KY	AB		J	Capacitor 4700p 25V Ceramic
C9628	RC-KZA213WJZZY	AC		J	Capacitor 4.7 25V Ceramic
C9629	RC-KZA213WJZZY	AC		J	Capacitor 4.7 25V Ceramic

NO.	PARTS CODE	PRICE RANK	NEW MARK	PART DELIVERY	DESCRIPTION
<b>[4] DUNTKF282FM06/07/11 (MAIN Unit)</b>					
C9630	RC-KZA403WJPZY	AB		J	Capacitor 4.7 6.3V Ceramic
C9631	RC-KZA616WJQZY	AB		J	Capacitor 10 10V Ceramic
C9632	RC-KZA616WJQZY	AB		J	Capacitor 10 10V Ceramic
C9635	VCKYCZ1HB222KY	AB		J	Capacitor 2200p 50V Ceramic
C9701	RC-KZA510WJPZY	AB		J	Capacitor 10 16V Ceramic
C9702	VCKYCZ1EB103KY	AA		J	Capacitor 0.01 25V Ceramic
C9709	VCKYCZ1EB103KY	AA		J	Capacitor 0.01 25V Ceramic
C9710	RC-KZA520WJQZY	AA		J	Capacitor 1 10V Ceramic
C9711	RC-KZA520WJQZY	AA		J	Capacitor 1 10V Ceramic
C9713	RC-KZA403WJPZY	AB		J	Capacitor 4.7 6.3V Ceramic
C9719	RC-KZA104WJZZY	AA		J	Capacitor 1 25V Ceramic
C9722	RC-KZA067WJZZY	AB		J	Capacitor 4.7 10V Ceramic
D523	VHDMAZ9120H-1Y	AC		J	Diode MAZ9120H0L
D524	VHDMAZ9120H-1Y	AC		J	Diode MAZ9120H0L
D525	VHDMAZ9120H-1Y	AC		J	Diode MAZ9120H0L
D526	VHDMAZ9120H-1Y	AC		J	Diode MAZ9120H0L
D527	VHDMAZ9120H-1Y	AC		J	Diode MAZ9120H0L
D528	VHDMAZ9120H-1Y	AC		J	Diode MAZ9120H0L
D529	VHDMAZ9120H-1Y	AC		J	Diode MAZ9120H0L
D530	VHDMAZ9120H-1Y	AC		J	Diode MAZ9120H0L
D531	VHDMAZ9120H-1Y	AC		J	Diode MAZ9120H0L
D532	VHDMAZ9120H-1Y	AC		J	Diode MAZ9120H0L
D1101	VHDRB056L40-1Y	AC		J	Diode RB056L-40TE25
D1102	VHDRB056L40-1Y	AC		J	Diode RB056L-40TE25
D1301	VHDKDS4148/-1Y	AA		J	Diode KDS4148U-RTK/P
D1302	VHD1SS361//--1Y	AB		J	Diode 1SS361(T5L,F,T)
D1305	VHD1SS361//--1Y	AB		J	Diode 1SS361(T5L,F,T)
D1306	VHPGPF5V51M-1	AG		J	Diode Photodiode
D1307	VHD1SS361//--1Y	AB		J	Diode 1SS361(T5L,F,T)
D1310	VHD1SS361//--1Y	AB		J	Diode 1SS361(T5L,F,T)
D1311	RH-EX0264TAZZY	AB		J	Diode PDZ9.1B,115
D1312	VHD1SS361//--1Y	AB		J	Diode 1SS361(T5L,F,T)
D1601	VHDRB520S30-1Y	AC		J	Diode RB520S-30TE61
D1602	VHD1PS226++-1Y	AB		J	Diode 1PS226,115
D1603	VHD1PS226++-1Y	AB		J	Diode 1PS226,115
D1606	RH-EXA523WJZZY	AB		J	Diode MAZ8056GML
D1607	VHD1PS226++-1Y	AB		J	Diode 1PS226,115
D1608	VHDMA152WK/-1Y	AB		J	Diode MA152WK-(TX)
D1609	VHDMA152WK/-1Y	AB		J	Diode MA152WK-(TX)
D1610	VHD1PS226++-1Y	AB		J	Diode 1PS226,115
D1805	VHDMA152WK/-1Y	AB		J	Diode MA152WK-(TX)
D1806	RH-EXA523WJZZY	AB		J	Diode MAZ8056GML
D1807	RH-EXA523WJZZY	AB		J	Diode MAZ8056GML
D1808	VHDMAZ9120H-1Y	AC		J	Diode MAZ9120H0L
D1809	VHDMAZ9120H-1Y	AC		J	Diode MAZ9120H0L
D1810	VHDMAZ9120H-1Y	AC		J	Diode MAZ9120H0L
D1811	VHDMA152WK/-1Y	AB		J	Diode MA152WK-(TX)
D1812	VHD1PS226++-1Y	AB		J	Diode 1PS226,115
D1813	VHD1PS226++-1Y	AB		J	Diode 1PS226,115
D1814	VHDMA152WK/-1Y	AB		J	Diode MA152WK-(TX)
D1815	VHD1PS226++-1Y	AB		J	Diode 1PS226,115
D1817	VHD1PS226++-1Y	AB		J	Diode 1PS226,115
D1818	VHD1PS226++-1Y	AB		J	Diode 1PS226,115
D1820	VHD1PS226++-1Y	AB		J	Diode 1PS226,115
D2504	VHDRB520S30-1Y	AC		J	Diode RB520S-30TE61
D2505	VHDMA152WK/-1Y	AB		J	Diode MA152WK-(TX)
D8001	RH-PXA018WJZZY	AC		J	Diode GM1HD55200A
D9001	VHDMAZ9120H-1Y	AC		J	Diode MAZ9120H0L
D9002	VHDMA111G++-1Y	AA		J	Diode MA2J1110GL
D9003	VHD1PS184++-1Y	AB		J	Diode 1PS184,115
D9005	VHDMAZ9120H-1Y	AC		J	Diode MAZ9120H0L
D9007	RH-EXA532WJZZY	AA		J	Diode MAZ8075GML
D9304	VHD1PS184++-1Y	AB		J	Diode 1PS184,115
D9601	VHDRB056L40-1Y	AC		J	Diode RB056L-40TE25
D9602	RH-EXA523WJZZY	AB		J	Diode MAZ8056GML
D9603	VHDMA111G++-1Y	AA		J	Diode MA2J1110GL
D9604	VHDRB056L40-1Y	AC		J	Diode RB056L-40TE25
D9605	VHD1PS226++-1Y	AB		J	Diode 1PS226,115
D9606	VHDRB056L40-1Y	AC		J	Diode RB056L-40TE25
D9607	RH-EXA507WJZZY	AA		J	Diode MAZ8033GLL
D9609	VHDMA111G++-1Y	AA		J	Diode MA2J1110GL
D9610	VHDMA111G++-1Y	AA		J	Diode MA2J1110GL
D9611	RH-EXA512WJZZY	AB		J	Diode MAZ8039GHL
D9701	VHDMA111G++-1Y	AA		J	Diode MA2J1110GL
D9702	VHDMA111G++-1Y	AA		J	Diode MA2J1110GL
D9703	VHDMA111G++-1Y	AA		J	Diode MA2J1110GL
D9713	VHD1PS184++-1Y	AB		J	Diode 1PS184,115
FB502	RBLN-A204WJZZY	AA		J	Ferrite Bead
FB505	RBLN-A045WJZZY	AB		J	Ferrite Bead
FB506	RBLN-A045WJZZY	AB		J	Ferrite Bead
FB507	RBLN-A204WJZZY	AA		J	Ferrite Bead
FB508	RBLN-A204WJZZY	AA		J	Ferrite Bead
FB509	RBLN-A204WJZZY	AA		J	Ferrite Bead
FB510	RBLN-A204WJZZY	AA		J	Ferrite Bead
FB511	RBLN-A045WJZZY	AB		J	Ferrite Bead

NO.	PARTS CODE	PRICE RANK	NEW MARK	PART DELIVERY	DESCRIPTION
<b>[4] DUNTKF282FM06/07/11 (MAIN Unit)</b>					
FB512	RBLN-A045WJZZY	AB		J	Ferrite Bead
FB513	RBLN-A204WJZZY	AA		J	Ferrite Bead
FB515	RBLN-A204WJZZY	AA		J	Ferrite Bead
FB516	RBLN-A204WJZZY	AA		J	Ferrite Bead
FB517	RBLN-A045WJZZY	AB		J	Ferrite Bead
FB518	RBLN-A045WJZZY	AB		J	Ferrite Bead
FB520	RBLN-A204WJZZY	AA		J	Ferrite Bead
FB521	RBLN-A204WJZZY	AA		J	Ferrite Bead
FB522	RBLN-A045WJZZY	AB		J	Ferrite Bead
FB523	RBLN-A045WJZZY	AB		J	Ferrite Bead
FB1101	RBLN-A206WJZZY	AA		J	Ferrite Bead
FB1605	RBLN-A192WJZZY	AA		J	Ferrite Bead
FB1802	RBLN-A045WJZZY	AB		J	Ferrite Bead
FB1803	RBLN-A045WJZZY	AB		J	Ferrite Bead
FB1804	RBLN-0093GEZZY	AB		J	Ferrite Bead
FB1805	RBLN-0093GEZZY	AB		J	Ferrite Bead
FB1806	RBLN-0093GEZZY	AB		J	Ferrite Bead
FB1807	RBLN-A204WJZZY	AA		J	Ferrite Bead
FB1808	RBLN-A204WJZZY	AA		J	Ferrite Bead
FB1812	RBLN-A192WJZZY	AA		J	Ferrite Bead
FB2001	RBLN-A206WJZZY	AA		J	Ferrite Bead
FB2002	RBLN-A005WJZZY	AA		J	Ferrite Bead
FB2003	RBLN-A005WJZZY	AA		J	Ferrite Bead
FB2004	RBLN-A005WJZZY	AA		J	Ferrite Bead
FB2005	RBLN-A378WJQZY	AA		J	Ferrite Bead
FB2006	RBLN-A378WJQZY	AA		J	Ferrite Bead
FB2007	RBLN-A375WJQZY	AA		J	Ferrite Bead
FB2008	RBLN-A375WJQZY	AA		J	Ferrite Bead
FB2009	RBLN-A375WJQZY	AA		J	Ferrite Bead
FB2010	RBLN-A375WJQZY	AA		J	Ferrite Bead
FB2011	RBLN-A375WJQZY	AA		J	Ferrite Bead
FB2012	RBLN-A375WJQZY	AA		J	Ferrite Bead
FB2013	RBLN-A375WJQZY	AA		J	Ferrite Bead
FB2014	RBLN-A378WJQZY	AA		J	Ferrite Bead
FB2508	RBLN-A192WJZZY	AA		J	Ferrite Bead
FB2602	RBLN-A375WJQZY	AA		J	Ferrite Bead
FB2603	RBLN-A375WJQZY	AA		J	Ferrite Bead
FB2604	RBLN-A375WJQZY	AA		J	Ferrite Bead
FB2605	RBLN-A375WJQZY	AA		J	Ferrite Bead
FB2606	RBLN-A375WJQZY	AA		J	Ferrite Bead
FB2607	RBLN-A375WJQZY	AA		J	Ferrite Bead
FB2608	RBLN-A375WJQZY	AA		J	Ferrite Bead
FB2609	RBLN-A204WJZZY	AA		J	Ferrite Bead
FB2610	RBLN-A074WJZZY	AA		J	Ferrite Bead
FB2611	RBLN-A074WJZZY	AA		J	Ferrite Bead
FB2613	RBLN-A204WJZZY	AA		J	Ferrite Bead
FB2614	RBLN-A074WJZZY	AA		J	Ferrite Bead
FB2615	RBLN-A074WJZZY	AA		J	Ferrite Bead
FB2616	RBLN-A074WJZZY	AA		J	Ferrite Bead
FB2617	RBLN-A074WJZZY	AA		J	Ferrite Bead
FB2618	RBLN-A074WJZZY	AA		J	Ferrite Bead
FB2620	RBLN-A074WJZZY	AA		J	Ferrite Bead
FB2621	RBLN-A074WJZZY	AA		J	Ferrite Bead
FB2622	RBLN-A074WJZZY	AA		J	Ferrite Bead
FB2623	RBLN-A074WJZZY	AA		J	Ferrite Bead
FB2624	RBLN-A074WJZZY	AA		J	Ferrite Bead
FB2625	RBLN-A074WJZZY	AA		J	Ferrite Bead
FB2626	RBLN-A074WJZZY	AA		J	Ferrite Bead
FB2627	RBLN-A074WJZZY	AA		J	Ferrite Bead
FB2628	RBLN-A074WJZZY	AA		J	Ferrite Bead
FB2629	RBLN-A074WJZZY	AA		J	Ferrite Bead
FB2630	RBLN-A074WJZZY	AA		J	Ferrite Bead
FB2631	RBLN-A074WJZZY	AA		J	Ferrite Bead
FB2632	RBLN-A074WJZZY	AA		J	Ferrite Bead
FB2639	RBLN-A375WJQZY	AA		J	Ferrite Bead
FB2640	RBLN-A375WJQZY	AA		J	Ferrite Bead
FB2641	RBLN-A375WJQZY	AA		J	Ferrite Bead
FB2702	RBLN-A206WJZZY	AA		J	Ferrite Bead
FB2703	RBLN-A206WJZZY	AA		J	Ferrite Bead
FB2704	RBLN-A206WJZZY	AA		J	Ferrite Bead
FB2705	RBLN-A206WJZZY	AA		J	Ferrite Bead
FB2706	RBLN-A206WJZZY	AA		J	Ferrite Bead
FB8001	RBLN-A206WJZZY	AA		J	Ferrite Bead
FB8002	RBLN-A206WJZZY	AA		J	Ferrite Bead
FB9001	RBLN-A042WJZZY	AB		J	Ferrite Bead
FB9002	RBLN-A042WJZZY	AB		J	Ferrite Bead
FB9003	RBLN-A192WJZZY	AA		J	Ferrite Bead
FB9004	RBLN-A042WJZZY	AB		J	Ferrite Bead
FB9701	RBLN-A074WJZZY	AA		J	Ferrite Bead
FB9702	RBLN-A375WJQZY	AA		J	Ferrite Bead
FB9703	RBLN-A375WJQZY	AA		J	Ferrite Bead
FB9704	RBLN-A375WJQZY	AA		J	Ferrite Bead
FB9705	RBLN-A375WJQZY	AA		J	Ferrite Bead
FB9706	RBLN-A375WJQZY	AA		J	Ferrite Bead
FB9707	RBLN-A375WJQZY	AA		J	Ferrite Bead

NO.	PARTS CODE	PRICE RANK	NEW MARK	PART DELIVERY	DESCRIPTION
<b>[4] DUNTKF282FM06/07/11 (MAIN Unit)</b>					
FB9708	RBLN-A375WJQZY	AA		J	Ferrite Bead
FB9709	RBLN-A074WJZZY	AA		J	Ferrite Bead
FB9710	RBLN-A074WJZZY	AA		J	Ferrite Bead
FB9711	RBLN-A375WJQZY	AA		J	Ferrite Bead
FB9712	RBLN-A375WJQZY	AA		J	Ferrite Bead
IC1101	VHiR1173S18-1Y	AE		J	IC R1173S181B-E2-F
IC1102	VHiMM3443DF-1Y	AD		J	IC MM3443DFBE
IC1104	VHiTAR5SB33-1Y	AD		J	IC TAR5SB33(TE85L,F)
IC1107	VHiLV5893M+-1Y	AE		J	IC LV5893M-TE-L-E
IC1108	VHiLV5893M+-1Y	AE		J	IC LV5893M-TE-L-E
IC1301	VHiLA79200V-1Y	AF		J	IC LA79200V-TLM-E
IC1304	VHiAHC1G08GW-1Y	AD		J	IC 74AHC1G08GW/G,125
IC1601	VHiCM123408-1Y	AE		J	IC CM1234-08DE
IC1602	VHiCM123408-1Y	AE		J	IC CM1234-08DE
IC1603	VHiTC7SH17U-1Y	AC		J	IC TC7SH17FU(TE85L,F)
IC1605	VHiSi9287+-1Q	AP		J	IC Si9287ACNU
IC1606	VHiTC7SH17U-1Y	AC		J	IC TC7SH17FU(TE85L,F)
IC1607	VHiLCX125FT-1Y	AD		J	IC TC74LCX125FT(EL,K)
IC1801	VHiSi9287+-1Q	AP		J	IC Si9287ACNU
IC1802	VHiLVC2G14G-1Y	AD		J	IC 74LVC2G14GW,125
IC1803	VHiCM123408-1Y	AE		J	IC CM1234-08DE
IC1804	VHiCM123408-1Y	AE		J	IC CM1234-08DE
IC1809	VHiS24CS02JHES			J	IC S-24CS02AFJ-TB-G (RGB EDID)
IC2001	VHiS80927NM-1Y	AC		J	IC S-80927CNMC-G8XT2G
IC2002	RH-iXC786WJN4Q			J	IC R5F364A6NFB (MONITOR MICON)
IC2004	VHiS24CS08J-1Y	AE		J	IC S-24CS08AFJ-TB-1G
IC2007	VHiAHC1G08GW-1Y	AD		J	IC 74AHC1G08GW/G,125
IC2008	VHi7WH126FU-1Y	AE		J	IC TC7WH126FU(TE12L,F)
IC2601	VHiHC2G66DP-1Y	AD		J	IC 74HC2G66DP,125
IC2604	VHiHC2G66DP-1Y	AD		J	IC 74HC2G66DP,125
IC2701	VHiYDA148QZ-1Y	AL		J	IC YDA148-QZE2
IC8001	RH-iXC579WJQZQ	BL		J	IC MT5391UFMJ
IC8002	VHiBD6538G+-1Y	AD		J	IC BD6538G-TR
IC8152	RH-iXC768WJQZQ	AU		X	IC H5PS5162FFR-G7C
IC8153	RH-iXC768WJQZQ	AU		X	IC H5PS5162FFR-G7C
IC8453	RH-iXC894WJQZQ	AQ		X	IC H27U518S2CTP-BC
IC8454	VHiS24CS64A-1Y	AF		J	IC S-24CS64AOI-J8T1G
IC9001	VHiTC7W00U/-1Y	AE		J	IC TC7W00FU(TE12L,F)
IC9002	VHi7WH126FU-1Y	AE		J	IC TC7WH126FU(TE12L,F)
IC9003	VHiM3222EiP-1Y	AK		J	IC MAX3222EIPower
IC9004	VHiLCX157FT-1Y	AD		J	IC TC74LCX157FT(EKJ)
IC9301	VHiAHC1G08GW-1Y	AD		J	IC 74AHC1G08GW/G,125
IC9601	VHiAOZ1021A-1Y	AF		J	IC AOZ1021AI
IC9602	VHiLV5893M+-1Y	AE		J	IC LV5893M-TE-L-E
IC9603	VHiLV5893M+-1Y	AE		J	IC LV5893M-TE-L-E
IC9604	VHiMM3443DF-1Y	AD		J	IC MM3443DFBE
IC9605	VHiMM3141YN-1Y	AC		J	IC MM3141YNRE
IC9606	VHiLV5893M+-1Y	AE		J	IC LV5893M-TE-L-E
IC9701	VHiR1154H00-1Y	AE		J	IC R1154H001C-T1-F
IC9703	VHiTCR5SB33-1Y	AC		J	IC TCR5SB33(TE85L,F)
J501	QJAKGA079WJZZ	AD		J	Jack 7Pin (INPUT 3)
J502	QJAKGA131WJZZ	AG		J	Jack 7Pin
J503	QJAKFA061WJZZ	AE		J	Jack 4Pin (INPUT 2)
J504	QSODA035WJZZ	AD		J	Socket 7Pin
J505	QJAKFA061WJZZ	AE		J	Jack 4Pin
J507	QJAKGA132WJQZ	AF		J	Jack 8Pin
J508	QJAKGA131WJZZ	AG		J	Jack 7Pin
J1801	QJAKEA103WJZZ	AD		J	Jack 3Pin
J8001	QSOCZA172WJQZ	AD		J	Jack 4Pin
L501	VPMTNR15JR25NY	AB		J	Peaking 0.15uH
L502	VPMTNR15JR25NY	AB		J	Peaking 0.15uH
L503	VPMTNR15JR25NY	AB		J	Peaking 0.15uH
L504	VPMTNR15JR25NY	AB		J	Peaking 0.15uH
L505	VPMTNR15JR25NY	AB		J	Peaking 0.15uH
L506	VPMTNR15JR25NY	AB		J	Peaking 0.15uH
L507	RcLPA903WJZZY	AC		J	Coil CiLPA903WJ
L1102	RcLPA899WJZZY	AC		J	Coil CiLPA899WJ
L1103	RcLPA899WJZZY	AC		J	Coil CiLPA899WJ
L1301	VPCEM100MR70NY	AC		J	Peaking 10uH
L1601	RcLFA116WJZZY	AE		J	Coil CiLFA116WJ
L1602	RcLFA116WJZZY	AE		J	Coil CiLFA116WJ
L1603	RcLFA116WJZZY	AE		J	Coil CiLFA116WJ
L1604	RcLFA116WJZZY	AE		J	Coil CiLFA116WJ
L1802	RcLFA116WJZZY	AE		J	Coil CiLFA116WJ
L1803	RcLFA116WJZZY	AE		J	Coil CiLFA116WJ
L1804	RcLFA116WJZZY	AE		J	Coil CiLFA116WJ
L1805	RcLFA116WJZZY	AE		J	Coil CiLFA116WJ
L2613	RcLFA157WJZZY	AC		J	Coil CiLFA157WJ
L2614	RcLFA157WJZZY	AC		J	Coil CiLFA157WJ
L2615	RcLFA157WJZZY	AC		J	Coil CiLFA157WJ
L2616	RcLFA157WJZZY	AC		J	Coil CiLFA157WJ
L2617	RcLFA157WJZZY	AC		J	Coil CiLFA157WJ
L2618	RcLFA157WJZZY	AC		J	Coil CiLFA157WJ
L2701	RcLPA888WJZZY	AG		J	Coil CiLPA888WJ
L2702	RcLPA888WJZZY	AG		J	Coil CiLPA888WJ

NO.	PARTS CODE	PRICE RANK	NEW MARK	PART DELIVERY	DESCRIPTION
<b>[4] DUNTKF282FM06/07/11 (MAIN Unit)</b>					
L2703	RCiLPA888WJZZY	AG		J	Coil CiLPA888WJ
L2704	RCiLPA888WJZZY	AG		J	Coil CiLPA888WJ
L8001	RCiLFA154WJZZY	AC		J	Coil CiLFA154WJ
L9601	RCiLPA898WJZZY	AC		J	Coil CiLPA898WJ
L9602	RCiLPA895WJZZY	AD		J	Coil CiLPA895WJ
L9603	RCiLPA897WJZZY	AD		J	Coil CiLPA897WJ
L9604	RCiLPA897WJZZY	AD		J	Coil CiLPA897WJ
LUG1101	QLUGHA006WJZZY	AC		J	Lug
LUG1102	QLUGHA006WJZZY	AC		J	Lug
LUG1103	QLUGHA006WJZZY	AC		J	Lug
LUG1104	QLUGHA006WJZZY	AC		J	Lug
LUG1105	QLUGHA006WJZZY	AC		J	Lug
LUG1106	QLUGHA006WJZZY	AC		J	Lug
LUG1110	QLUGHA006WJZZY	AC		J	Lug
LUG1114	QLUGHA006WJZZY	AC		J	Lug
P2002	QPLGNA338WJZZY	AD		J	Plug 4Pin (KM)
P2003	QPLGNA330WJZZY	AD		J	Plug 10Pin (RA)
P2601	QCNCWA960WJQZY	AG		X	Plug 41Pin (LW)
P2602	QPLGNA349WJZZY	AE		J	Plug 15Pin (LP)
P2603	QPLGNA343WJZZY	AD		J	Plug 9Pin (LB)
P2701	QPLGNA160WJZZY	AD		J	Plug 4Pin (SP)
P9701	QPLGNA181WJZZY	AF		J	Plug 12Pin (PD)
Q519	VSKTC3875SG-1Y	AB		J	Transistor KTC3875SG
Q520	VSKTC3875SG-1Y	AB		J	Transistor KTC3875SG
Q1101	VSKTC3875SG-1Y	AB		J	Transistor KTC3875SG
Q1102	VSKTC3875SG-1Y	AB		J	Transistor KTC3875SG
Q1304	VSKRC404E+-1Y	AB		J	Transistor KRC404E-RTK
Q1305	VSKRC404E+-1Y	AB		J	Transistor KRC404E-RTK
Q1306	VSRT3Y97M+-1Y	AC		J	Transistor RT3Y970-T111-1
Q1309	VSKTC3875SG-1Y	AB		J	Transistor KTC3875SG
Q1311	VSRT3Y97M+-1Y	AC		J	Transistor RT3Y970-T111-1
Q1312	VSKRC404E+-1Y	AB		J	Transistor KRC404E-RTK
Q1609	VSKRC402E+-1Y	AB		J	Transistor KRC402E
Q1610	VSKTA1535T+-1Y	AC		J	Transistor KTA1535T-RTK/P
Q1804	VSKRC402E+-1Y	AB		J	Transistor KRC402E
Q1808	VSKTA1535T+-1Y	AC		J	Transistor KTA1535T-RTK/P
Q1812	VSRN4983///-1Y	AC		J	Transistor RN4983(TE85L,F)
Q2002	VSRN4901///-1Y	AC		J	Transistor RN4901(TE85L,F)
Q2003	VSRT1P141U/-1Y	AB		J	Transistor RT1P141U-T111-1
Q2004	VSRT1N141U/-1Y	AB		J	Transistor RT1N141U-T111-1
Q2006	VSRT1N141U/-1Y	AB		J	Transistor RT1N141U-T111-1
Q2603	VSKRC404E+-1Y	AB		J	Transistor KRC404E-RTK
Q2704	VSKRC404E+-1Y	AB		J	Transistor KRC404E-RTK
Q9001	VSRN1102///-1Y	AB		J	Transistor RN1102(TE85L,F)
Q9602	VSRT1N141U/-1Y	AB		J	Transistor RT1N141U-T111-1
Q9603	VSKTC3875SG-1Y	AB		J	Transistor KTC3875SG
Q9701	VSRN4982///-1Y	AB		J	Transistor RN4982(TE85L,F)
Q9702	VSRN4982///-1Y	AB		J	Transistor RN4982(TE85L,F)
Q9705	VS2SA1530AR-1Y	AB		J	Transistor 2SA1530A-T112-1R
Q9706	VS2SA1530AR-1Y	AB		J	Transistor 2SA1530A-T112-1R
Q9707	VSHN7G04FUA-1Y	AB		J	Transistor HN7G04FU-A(TE85L,F)
R509	VRS-CZ1JF221JY	AA		J	Resistor 220 1/16W Metal Oxide
R510	VRS-CZ1JF104JY	AA		J	Resistor 100k 1/16W Metal Oxide
R511	VRS-CZ1JF221JY	AA		J	Resistor 220 1/16W Metal Oxide
R512	VRS-CZ1JF104JY	AA		J	Resistor 100k 1/16W Metal Oxide
R514	VRS-CZ1JF102JY	AA		J	Resistor 1k 1/16W Metal Oxide
R515	VRS-TV1JD750JY	AA		J	Resistor 75 1/10W Metal Oxide
R526	VRS-CZ1JF102JY	AA		J	Resistor 1k 1/16W Metal Oxide
R535	VRS-CZ1JF221JY	AA		J	Resistor 220 1/16W Metal Oxide
R536	VRS-CZ1JF104JY	AA		J	Resistor 100k 1/16W Metal Oxide
R537	VRS-CZ1JF000JY	AA		J	Resistor 0 1/16W Metal Oxide
R538	VRS-CZ1JF000JY	AA		J	Resistor 0 1/16W Metal Oxide
R539	VRS-CZ1JF221JY	AA		J	Resistor 220 1/16W Metal Oxide
R540	VRS-CZ1JF104JY	AA		J	Resistor 100k 1/16W Metal Oxide
R543	VRS-CZ1JF103JY	AA		J	Resistor 10k 1/16W Metal Oxide
R544	VRS-CZ1JF103JY	AA		J	Resistor 10k 1/16W Metal Oxide
R545	VRS-CZ1JF102JY	AA		J	Resistor 1k 1/16W Metal Oxide
R546	VRS-CZ1JF103JY	AA		J	Resistor 10k 1/16W Metal Oxide
R547	VRS-CZ1JF103JY	AA		J	Resistor 10k 1/16W Metal Oxide
R549	VRS-CZ1JF103JY	AA		J	Resistor 10k 1/16W Metal Oxide
R552	VRS-CZ1JF221JY	AA		J	Resistor 220 1/16W Metal Oxide
R554	VRS-CZ1JF104JY	AA		J	Resistor 100k 1/16W Metal Oxide
R555	VRS-CZ1JF221JY	AA		J	Resistor 220 1/16W Metal Oxide
R558	VRS-CZ1JF104JY	AA		J	Resistor 100k 1/16W Metal Oxide
R559	VRS-CZ1JF000JY	AA		J	Resistor 0 1/16W Metal Oxide
R561	VRS-CZ1JF000JY	AA		J	Resistor 0 1/16W Metal Oxide
R569	VRS-TV1JD750JY	AA		J	Resistor 75 1/10W Metal Oxide
R572	VRS-CZ1JF102JY	AA		J	Resistor 1k 1/16W Metal Oxide
R573	VRS-CZ1JF104JY	AA		J	Resistor 100k 1/16W Metal Oxide
R574	VRS-TV1JD750JY	AA		J	Resistor 75 1/10W Metal Oxide
R579	VRS-CZ1JF221JY	AA		J	Resistor 220 1/16W Metal Oxide
R580	VRS-CZ1JF104JY	AA		J	Resistor 100k 1/16W Metal Oxide
R581	VRS-CZ1JF221JY	AA		J	Resistor 220 1/16W Metal Oxide
R582	VRS-CZ1JF104JY	AA		J	Resistor 100k 1/16W Metal Oxide
R588	VRS-CZ1JF104JY	AA		J	Resistor 100k 1/16W Metal Oxide

NO.	PARTS CODE	PRICE RANK	NEW MARK	PART DELIVERY	DESCRIPTION
<b>[4] DUNTKF282FM06/07/11 (MAIN Unit)</b>					
R589	VRS-CZ1JF104JY	AA		J	Resistor 100k 1/16W Metal Oxide
R590	VRS-CZ1JF102JY	AA		J	Resistor 1k 1/16W Metal Oxide
R591	VRS-TV1JD750JY	AA		J	Resistor 75 1/10W Metal Oxide
R592	VRS-CZ1JF104JY	AA		J	Resistor 100k 1/16W Metal Oxide
R596	VRS-TV1JD471JY	AA		J	Resistor 470 1/10W Metal Oxide
R597	VRS-TV1JD471JY	AA		J	Resistor 470 1/10W Metal Oxide
R601	VRS-CZ1JF470JY	AA		J	Resistor 47 1/16W Metal Oxide
R602	VRS-CZ1JF470JY	AA		J	Resistor 47 1/16W Metal Oxide
R1101	VRS-CZ1JF470JY	AA		J	Resistor 47 1/16W Metal Oxide
R1102	VRS-CZ1JF470JY	AA		J	Resistor 47 1/16W Metal Oxide
R1104	VRS-CZ1JF4R7JY	AA		J	Resistor 4.7 1/16W Metal Oxide
R1105	VRS-CZ1JF103JY	AA		J	Resistor 10k 1/16W Metal Oxide
R1106	VRS-CZ1JF4R7JY	AA		J	Resistor 4.7 1/16W Metal Oxide
R1107	VRS-CZ1JF000JY	AA		J	Resistor 0 1/16W Metal Oxide
R1108	VRS-CZ1JF390JY	AA		J	Resistor 39 1/16W Metal Oxide
R1109	VRS-CZ1JF331JY	AA		J	Resistor 330 1/16W Metal Oxide
R1113	VRS-CZ1JF123FY	AA		J	Resistor 12k 1/16W Metal Oxide
R1114	VRS-CZ1JF392JY	AA		J	Resistor 3.9k 1/16W Metal Oxide
R1115	VRS-CZ1JF101JY	AA		J	Resistor 100 1/16W Metal Oxide
R1118	VRS-CZ1JF272FY	AA		J	Resistor 2.7k 1/16W Metal Oxide
R1119	VRS-CZ1JF182JY	AA		J	Resistor 1.8k 1/16W Metal Oxide
R1120	VRS-CZ1JF222JY	AA		J	Resistor 2.2k 1/16W Metal Oxide
R1121	VRS-CZ1JF101JY	AA		J	Resistor 100 1/16W Metal Oxide
R1123	VRS-CZ1JF000JY	AA		J	Resistor 0 1/16W Metal Oxide
R1124	VRS-CZ1JF000JY	AA		J	Resistor 0 1/16W Metal Oxide
R1125	VRS-CZ1JF472JY	AA		J	Resistor 4.7k 1/16W Metal Oxide
R1127	VRS-CZ1JF000JY	AA		J	Resistor 0 1/16W Metal Oxide
R1128	VRS-CZ1JF103JY	AA		J	Resistor 10k 1/16W Metal Oxide
R1129	VRS-CZ1JF390JY	AA		J	Resistor 39 1/16W Metal Oxide
R1133	VRS-CZ1JF000JY	AA		J	Resistor 0 1/16W Metal Oxide
R1134	VRS-CY1JF000JY	AA		J	Resistor 0 1/16W Metal Oxide
R1135	VRS-CY1JF000JY	AA		J	Resistor 0 1/16W Metal Oxide
R1136	VRS-CZ1JF101JY	AA		J	Resistor 100 1/16W Metal Oxide
R1137	VRS-CZ1JF101JY	AA		J	Resistor 100 1/16W Metal Oxide
R1138	VRS-CZ1JF000JY	AA		J	Resistor 0 1/16W Metal Oxide
R1139	VRS-CZ1JF000JY	AA		J	Resistor 0 1/16W Metal Oxide
R1140	VRS-CZ1JF000JY	AA		J	Resistor 0 1/16W Metal Oxide
R1141	VRS-CY1JF000JY	AA		J	Resistor 0 1/16W Metal Oxide
R1142	VRS-CY1JF000JY	AA		J	Resistor 0 1/16W Metal Oxide
R1145	VRS-CZ1JF472JY	AA		J	Resistor 4.7k 1/16W Metal Oxide
R1146	VRS-CZ1JF103FY	AB		J	Resistor 10k 1/16W Metal Oxide
R1147	VRS-CZ1JF472JY	AA		J	Resistor 4.7k 1/16W Metal Oxide
R1148	VRS-CZ1JF103FY	AB		J	Resistor 10k 1/16W Metal Oxide
R1149	VRS-CZ1JF153JY	AA		J	Resistor 15k 1/16W Metal Oxide
R1150	VRS-CZ1JF393FY	AA		J	Resistor 39k 1/16W Metal Oxide
R1151	VRS-CZ1JF562JY	AA		J	Resistor 5.6k 1/16W Metal Oxide
R1152	VRS-CZ1JF000JY	AA		J	Resistor 0 1/16W Metal Oxide
R1153	VRS-CZ1JF103JY	AA		J	Resistor 10k 1/16W Metal Oxide
R1301	VRS-CJ1JF470JY	AA		J	Resistor 47 1/16W Metal Oxide
R1302	VRS-CG1JF202JY	AA		J	Resistor 2.0k 1/16W Metal Oxide
R1305	VRS-CZ1JF000JY	AA		J	Resistor 0 1/16W Metal Oxide
R1308	VRS-CZ1JF222JY	AA		J	Resistor 2.2k 1/16W Metal Oxide
R1310	VRS-CZ1JF102JY	AA		J	Resistor 1k 1/16W Metal Oxide
R1311	VRS-CZ1JF220JY	AA		J	Resistor 22 1/16W Metal Oxide
R1317	VRS-CZ1JF392JY	AA		J	Resistor 3.9k 1/16W Metal Oxide
R1318	VRS-CZ1JF392JY	AA		J	Resistor 3.9k 1/16W Metal Oxide
R1323	VRS-CZ1JF103JY	AA		J	Resistor 10k 1/16W Metal Oxide
R1328	VRS-CG1JF472JY	AA		J	Resistor 4.7k 1/16W Metal Oxide
R1329	VRS-CZ1JF153JY	AA		J	Resistor 15k 1/16W Metal Oxide
R1330	VRS-CZ1JF153JY	AA		J	Resistor 15k 1/16W Metal Oxide
R1333	VRS-CZ1JF223JY	AA		J	Resistor 22k 1/16W Metal Oxide
R1334	VRS-CZ1JF102JY	AA		J	Resistor 1k 1/16W Metal Oxide
R1335	VRS-CZ1JF562JY	AA		J	Resistor 5.6k 1/16W Metal Oxide
R1337	VRS-CZ1JF562JY	AA		J	Resistor 5.6k 1/16W Metal Oxide
R1338	VRS-CZ1JF472JY	AA		J	Resistor 4.7k 1/16W Metal Oxide
R1339	VRS-CZ1JF222JY	AA		J	Resistor 2.2k 1/16W Metal Oxide
R1340	VRS-CY1JF564JY	AA		J	Resistor 560k 1/16W Metal Oxide
R1342	VRS-CY1JF564JY	AA		J	Resistor 560k 1/16W Metal Oxide
R1345	VRS-CZ1JF153JY	AA		J	Resistor 15k 1/16W Metal Oxide
R1602	VRS-CZ1JF273JY	AA		J	Resistor 27k 1/16W Metal Oxide
R1603	VRS-CZ1JF000JY	AA		J	Resistor 0 1/16W Metal Oxide
R1606	VRS-CZ1JF103JY	AA		J	Resistor 10k 1/16W Metal Oxide
R1609	VRS-CZ1JF000JY	AA		J	Resistor 0 1/16W Metal Oxide
R1610	VRS-CZ1JF103JY	AA		J	Resistor 10k 1/16W Metal Oxide
R1615	VRS-CZ1JF473JY	AA		J	Resistor 47k 1/16W Metal Oxide
R1618	VRS-CZ1JF473JY	AA		J	Resistor 47k 1/16W Metal Oxide
R1620	VRS-CZ1JF473JY	AA		J	Resistor 47k 1/16W Metal Oxide
R1621	VRS-CZ1JF473JY	AA		J	Resistor 47k 1/16W Metal Oxide
R1638	VRS-CZ1JF103JY	AA		J	Resistor 10k 1/16W Metal Oxide
R1639	VRS-CZ1JF331JY	AA		J	Resistor 330 1/16W Metal Oxide
R1640	VRS-CZ1JF103JY	AA		J	Resistor 10k 1/16W Metal Oxide
R1641	VRS-CZ1JF100JY	AA		J	Resistor 10 1/16W Metal Oxide
R1642	VRS-CZ1JF100JY	AA		J	Resistor 10 1/16W Metal Oxide
R1644	VRS-CZ1JF100JY	AA		J	Resistor 10 1/16W Metal Oxide
R1645	VRS-CZ1JF100JY	AA		J	Resistor 10 1/16W Metal Oxide

NO.	PARTS CODE	PRICE RANK	NEW MARK	PART DELIVERY	DESCRIPTION
<b>[4] DUNTKF282FM06/07/11 (MAIN Unit)</b>					
R1646	VRS-CZ1JF472JY	AA		J	Resistor 4.7k 1/16W Metal Oxide
R1648	VRS-CZ1JF332JY	AA		J	Resistor 3.3k 1/16W Metal Oxide
R1651	VRS-CZ1JF473JY	AA		J	Resistor 47k 1/16W Metal Oxide
R1652	VRS-CZ1JF473JY	AA		J	Resistor 47k 1/16W Metal Oxide
R1653	VRS-CZ1JF473JY	AA		J	Resistor 47k 1/16W Metal Oxide
R1654	VRS-CZ1JF473JY	AA		J	Resistor 47k 1/16W Metal Oxide
R1655	VRS-CZ1JF100JY	AA		J	Resistor 10 1/16W Metal Oxide
R1656	VRS-CZ1JF100JY	AA		J	Resistor 10 1/16W Metal Oxide
R1657	VRS-CZ1JF100JY	AA		J	Resistor 10 1/16W Metal Oxide
R1658	VRS-CZ1JF100JY	AA		J	Resistor 10 1/16W Metal Oxide
R1660	VRS-CZ1JF222JY	AA		J	Resistor 2.2k 1/16W Metal Oxide
R1663	VRS-CZ1JF103JY	AA		J	Resistor 10k 1/16W Metal Oxide
R1665	VRS-CZ1JF103JY	AA		J	Resistor 10k 1/16W Metal Oxide
R1668	VRS-CZ1JF000JY	AA		J	Resistor 0 1/16W Metal Oxide
R1669	VRS-CZ1JF100JY	AA		J	Resistor 10 1/16W Metal Oxide
R1670	VRS-CZ1JF100JY	AA		J	Resistor 10 1/16W Metal Oxide
R1671	VRS-CZ1JF100JY	AA		J	Resistor 10 1/16W Metal Oxide
R1672	VRS-CZ1JF100JY	AA		J	Resistor 10 1/16W Metal Oxide
R1685	VRS-CZ1JF103JY	AA		J	Resistor 10k 1/16W Metal Oxide
R1686	VRS-CZ1JF332JY	AA		J	Resistor 3.3k 1/16W Metal Oxide
R1687	VRS-CZ1JF332JY	AA		J	Resistor 3.3k 1/16W Metal Oxide
R1688	VRS-CZ1JF332JY	AA		J	Resistor 3.3k 1/16W Metal Oxide
R1689	VRS-CZ1JF332JY	AA		J	Resistor 3.3k 1/16W Metal Oxide
R1690	VRS-CZ1JF000JY	AA		J	Resistor 0 1/16W Metal Oxide
R1694	VRS-CZ1JF000JY	AA		J	Resistor 0 1/16W Metal Oxide
R1695	VRS-CZ1JF000JY	AA		J	Resistor 0 1/16W Metal Oxide
R1801	VRS-CZ1JF000JY	AA		J	Resistor 0 1/16W Metal Oxide
R1806	VRS-CZ1JF000JY	AA		J	Resistor 0 1/16W Metal Oxide
R1807	VRS-CZ1JF000JY	AA		J	Resistor 0 1/16W Metal Oxide
R1811	VRS-CZ1JF473JY	AA		J	Resistor 47k 1/16W Metal Oxide
R1814	VRS-CZ1JF104JY	AA		J	Resistor 100k 1/16W Metal Oxide
R1815	VRS-CZ1JF104JY	AA		J	Resistor 100k 1/16W Metal Oxide
R1816	VRS-CZ1JF221JY	AA		J	Resistor 220 1/16W Metal Oxide
R1817	VRS-CZ1JF221JY	AA		J	Resistor 220 1/16W Metal Oxide
R1818	VRS-CZ1JF222JY	AA		J	Resistor 2.2k 1/16W Metal Oxide
R1819	VRS-CZ1JF222JY	AA		J	Resistor 2.2k 1/16W Metal Oxide
R1820	VRS-CZ1JF101JY	AA		J	Resistor 100 1/16W Metal Oxide
R1821	VRS-CZ1JF101JY	AA		J	Resistor 100 1/16W Metal Oxide
R1822	VRS-CZ1JF473JY	AA		J	Resistor 47k 1/16W Metal Oxide
R1824	VRS-CZ1JF473JY	AA		J	Resistor 47k 1/16W Metal Oxide
R1825	VRS-TV1JD750JY	AA		J	Resistor 75 1/10W Metal Oxide
R1826	VRS-TV1JD750JY	AA		J	Resistor 75 1/10W Metal Oxide
R1827	VRS-TV1JD750JY	AA		J	Resistor 75 1/10W Metal Oxide
R1828	VRS-CZ1JF330JY	AA		J	Resistor 33 1/16W Metal Oxide
R1838	VRS-CZ1JF330JY	AA		J	Resistor 33 1/16W Metal Oxide
R1842	VRS-CZ1JF000JY	AA		J	Resistor 0 1/16W Metal Oxide
R1846	VRS-CZ1JF000JY	AA		J	Resistor 0 1/16W Metal Oxide
R1847	VRS-CZ1JF473JY	AA		J	Resistor 47k 1/16W Metal Oxide
R1848	VRS-CZ1JF473JY	AA		J	Resistor 47k 1/16W Metal Oxide
R1850	VRS-CZ1JF473JY	AA		J	Resistor 47k 1/16W Metal Oxide
R1851	VRS-CZ1JF103JY	AA		J	Resistor 10k 1/16W Metal Oxide
R1852	VRS-CZ1JF331JY	AA		J	Resistor 330 1/16W Metal Oxide
R1853	VRS-CZ1JF103JY	AA		J	Resistor 10k 1/16W Metal Oxide
R1854	VRS-CZ1JF100JY	AA		J	Resistor 10 1/16W Metal Oxide
R1855	VRS-CZ1JF100JY	AA		J	Resistor 10 1/16W Metal Oxide
R1857	VRS-CZ1JF473JY	AA		J	Resistor 47k 1/16W Metal Oxide
R1858	VRS-CZ1JF473JY	AA		J	Resistor 47k 1/16W Metal Oxide
R1860	VRS-CZ1JF332JY	AA		J	Resistor 3.3k 1/16W Metal Oxide
R1864	VRS-CZ1JF473JY	AA		J	Resistor 47k 1/16W Metal Oxide
R1865	VRS-CZ1JF473JY	AA		J	Resistor 47k 1/16W Metal Oxide
R1866	VRS-CZ1JF473JY	AA		J	Resistor 47k 1/16W Metal Oxide
R1867	VRS-CZ1JF473JY	AA		J	Resistor 47k 1/16W Metal Oxide
R1868	VRS-CZ1JF100JY	AA		J	Resistor 10 1/16W Metal Oxide
R1869	VRS-CZ1JF100JY	AA		J	Resistor 10 1/16W Metal Oxide
R1870	VRS-CZ1JF100JY	AA		J	Resistor 10 1/16W Metal Oxide
R1871	VRS-CZ1JF100JY	AA		J	Resistor 10 1/16W Metal Oxide
R1872	VRS-CZ1JF222JY	AA		J	Resistor 2.2k 1/16W Metal Oxide
R1881	VRS-CZ1JF470JY	AA		J	Resistor 47 1/16W Metal Oxide
R1882	VRS-CZ1JF470JY	AA		J	Resistor 47 1/16W Metal Oxide
R1883	VRS-CZ1JF470JY	AA		J	Resistor 47 1/16W Metal Oxide
R1885	VRS-CZ1JF100JY	AA		J	Resistor 10 1/16W Metal Oxide
R1886	VRS-CZ1JF332JY	AA		J	Resistor 3.3k 1/16W Metal Oxide
R1888	VRS-CZ1JF100JY	AA		J	Resistor 10 1/16W Metal Oxide
R1889	VRS-CZ1JF100JY	AA		J	Resistor 10 1/16W Metal Oxide
R1899	VRS-CZ1JF473JY	AA		J	Resistor 47k 1/16W Metal Oxide
R1900	VRS-CZ1JF100JY	AA		J	Resistor 10 1/16W Metal Oxide
R1901	VRS-CZ1JF100JY	AA		J	Resistor 10 1/16W Metal Oxide
R1916	VRS-CZ1JF103JY	AA		J	Resistor 10k 1/16W Metal Oxide
R1917	VRS-CZ1JF332JY	AA		J	Resistor 3.3k 1/16W Metal Oxide
R1918	VRS-CZ1JF332JY	AA		J	Resistor 3.3k 1/16W Metal Oxide
R1919	VRS-CZ1JF332JY	AA		J	Resistor 3.3k 1/16W Metal Oxide
R1920	VRS-CZ1JF000JY	AA		J	Resistor 0 1/16W Metal Oxide
R2001	VRS-CZ1JF101JY	AA		J	Resistor 100 1/16W Metal Oxide
R2002	VRS-CZ1JF104JY	AA		J	Resistor 100k 1/16W Metal Oxide
R2003	VRS-CZ1JF102JY	AA		J	Resistor 1k 1/16W Metal Oxide

NO.	PARTS CODE	PRICE RANK	NEW MARK	PART DELIVERY	DESCRIPTION
<b>[4] DUNTKF282FM06/07/11 (MAIN Unit)</b>					
R2004	VRS-CZ1JF103JY	AA		J	Resistor 10k 1/16W Metal Oxide
R2006	VRS-CZ1JF223JY	AA		J	Resistor 22k 1/16W Metal Oxide
R2007	VRS-CZ1JF472JY	AA		J	Resistor 4.7k 1/16W Metal Oxide
R2008	VRS-CZ1JF102JY	AA		J	Resistor 1k 1/16W Metal Oxide
R2009	VRS-CZ1JF102JY	AA		J	Resistor 1k 1/16W Metal Oxide
R2010	VRS-CZ1JF333JY	AA		J	Resistor 33k 1/16W Metal Oxide
R2011	VRS-CZ1JF472JY	AA		J	Resistor 4.7k 1/16W Metal Oxide
R2012	VRS-CH1JF103JY	AA		J	Resistor 10k 1/16W Metal Oxide
R2014	VRS-CZ1JF472JY	AA		J	Resistor 4.7k 1/16W Metal Oxide
R2015	VRS-CZ1JF103JY	AA		J	Resistor 10k 1/16W Metal Oxide
R2016	VRS-CZ1JF103JY	AA		J	Resistor 10k 1/16W Metal Oxide
R2017	VRS-CZ1JF103JY	AA		J	Resistor 10k 1/16W Metal Oxide
R2018	VRS-CZ1JF103JY	AA		J	Resistor 10k 1/16W Metal Oxide
R2019	VRS-CZ1JF103JY	AA		J	Resistor 10k 1/16W Metal Oxide
R2020	VRS-CZ1JF103JY	AA		J	Resistor 10k 1/16W Metal Oxide
R2022	VRS-CZ1JF333JY	AA		J	Resistor 33k 1/16W Metal Oxide
R2023	VRS-CZ1JF473FY	AA		J	Resistor 47k 1/16W Metal Oxide
R2024	VRS-CZ1JF102JY	AA		J	Resistor 1k 1/16W Metal Oxide
R2025	VRS-CZ1JF103JY	AA		J	Resistor 10k 1/16W Metal Oxide
R2026	VRS-CZ1JF103JY	AA		J	Resistor 10k 1/16W Metal Oxide
R2028	VRS-CZ1JF103JY	AA		J	Resistor 10k 1/16W Metal Oxide
R2029	VRS-CZ1JF100JY	AA		J	Resistor 10 1/16W Metal Oxide
R2030	VRS-CZ1JF472JY	AA		J	Resistor 4.7k 1/16W Metal Oxide
R2031	VRS-CZ1JF103JY	AA		J	Resistor 10k 1/16W Metal Oxide
R2032	VRS-CZ1JF223JY	AA		J	Resistor 22k 1/16W Metal Oxide
R2033	VRS-CZ1JF101JY	AA		J	Resistor 100 1/16W Metal Oxide
R2034	VRS-CZ1JF000JY	AA		J	Resistor 0 1/16W Metal Oxide
R2036	VRS-CZ1JF105JY	AA		J	Resistor 1M 1/16W Metal Oxide
R2038	VRS-CZ1JF000JY	AA		J	Resistor 0 1/16W Metal Oxide
R2042	VRS-CH1JF101JY	AA		J	Resistor 100 1/16W Metal Oxide
R2044	VRS-CZ1JF100JY	AA		J	Resistor 10 1/16W Metal Oxide
R2047	VRS-CZ1JF101JY	AA		J	Resistor 100 1/16W Metal Oxide
R2048	VRS-CZ1JF472JY	AA		J	Resistor 4.7k 1/16W Metal Oxide
R2049	VRS-CZ1JF272FY	AA		J	Resistor 2.7k 1/16W Metal Oxide
R2050	VRS-CZ1JF101JY	AA		J	Resistor 100 1/16W Metal Oxide
R2051	VRS-CZ1JF100JY	AA		J	Resistor 10 1/16W Metal Oxide
R2052	VRS-CZ1JF100JY	AA		J	Resistor 10 1/16W Metal Oxide
R2057	VRS-CZ1JF103JY	AA		J	Resistor 10k 1/16W Metal Oxide
R2058	VRS-CZ1JF100JY	AA		J	Resistor 10 1/16W Metal Oxide
R2060	VRS-CZ1JF100JY	AA		J	Resistor 10 1/16W Metal Oxide
R2061	VRS-CZ1JF100JY	AA		J	Resistor 10 1/16W Metal Oxide
R2062	VRS-CZ1JF223JY	AA		J	Resistor 22k 1/16W Metal Oxide
R2063	VRS-CZ1JF223JY	AA		J	Resistor 22k 1/16W Metal Oxide
R2064	VRS-CZ1JF100JY	AA		J	Resistor 10 1/16W Metal Oxide
R2068	VRS-CZ1JF103JY	AA		J	Resistor 10k 1/16W Metal Oxide
R2070	VRS-CZ1JF100JY	AA		J	Resistor 10 1/16W Metal Oxide
R2071	VRS-CZ1JF100JY	AA		J	Resistor 10 1/16W Metal Oxide
R2072	VRS-CZ1JF104JY	AA		J	Resistor 100k 1/16W Metal Oxide
R2075	VRS-CZ1JF103JY	AA		J	Resistor 10k 1/16W Metal Oxide
R2077	VRS-CZ1JF101JY	AA		J	Resistor 100 1/16W Metal Oxide
R2078	VRS-CZ1JF103JY	AA		J	Resistor 10k 1/16W Metal Oxide
R2505	VRS-CZ1JF473JY	AA		J	Resistor 47k 1/16W Metal Oxide
R2506	VRS-CZ1JF473JY	AA		J	Resistor 47k 1/16W Metal Oxide
R2507	VRS-CZ1JF273JY	AA		J	Resistor 27k 1/16W Metal Oxide
R2601	VRS-CH1JF223JY	AA		J	Resistor 22k 1/16W Metal Oxide
R2602	VRS-CH1JF223JY	AA		J	Resistor 22k 1/16W Metal Oxide
R2603	VRS-CZ1JF223JY	AA		J	Resistor 22k 1/16W Metal Oxide
R2605	VRS-CZ1JF103JY	AA		J	Resistor 10k 1/16W Metal Oxide
R2619	VRS-CZ1JF000JY	AA		J	Resistor 0 1/16W Metal Oxide
R2620	VRS-CZ1JF000JY	AA		J	Resistor 0 1/16W Metal Oxide
R2621	VRS-CZ1JF105JY	AA		J	Resistor 1M 1/16W Metal Oxide
R2622	VRS-CZ1JF000JY	AA		J	Resistor 0 1/16W Metal Oxide
R2624	VRS-CZ1JF000JY	AA		J	Resistor 0 1/16W Metal Oxide
R2635	VRS-CZ1JF103JY	AA		J	Resistor 10k 1/16W Metal Oxide
R2636	VRS-CZ1JF105JY	AA		J	Resistor 1M 1/16W Metal Oxide
R2639	VRS-CZ1JF104JY	AA		J	Resistor 100k 1/16W Metal Oxide
R2641	VRS-CZ1JF000JY	AA		J	Resistor 0 1/16W Metal Oxide
R2642	VRS-CZ1JF000JY	AA		J	Resistor 0 1/16W Metal Oxide
R2643	VRS-CZ1JF000JY	AA		J	Resistor 0 1/16W Metal Oxide
R2644	VRS-CZ1JF000JY	AA		J	Resistor 0 1/16W Metal Oxide
R2651	VRS-CZ1JF103JY	AA		J	Resistor 10k 1/16W Metal Oxide
R2653	VRS-CZ1JF101JY	AA		J	Resistor 100 1/16W Metal Oxide
R2655	VRS-CZ1JF103JY	AA		J	Resistor 10k 1/16W Metal Oxide
R2656	VRS-CZ1JF000JY	AA		J	Resistor 0 1/16W Metal Oxide
R2715	VRS-CZ1JF224FY	AA		J	Resistor 220k 1/16W Metal Oxide
R2717	VRS-CZ1JF273FY	AA		J	Resistor 27k 1/16W Metal Oxide
R2719	VRS-CZ1JF562JY	AA		J	Resistor 5.6k 1/16W Metal Oxide
R2726	VRS-CZ1JF000JY	AA		J	Resistor 0 1/16W Metal Oxide
R2731	VRS-CZ1JF000JY	AA		J	Resistor 0 1/16W Metal Oxide
R2741	VRS-CZ1JF753JY	AA		J	Resistor 75k 1/16W Metal Oxide
R2742	VRS-CZ1JF203JY	AA		J	Resistor 20k 1/16W Metal Oxide
R2744	VRS-CZ1JF220JY	AA		J	Resistor 22 1/16W Metal Oxide
R2752	VRS-CZ1JF224FY	AA		J	Resistor 220k 1/16W Metal Oxide
R2753	VRS-CZ1JF683FY	AA		J	Resistor 68k 1/16W Metal Oxide
R2754	VRS-CZ1JF223FY	AA		J	Resistor 22k 1/16W Metal Oxide

NO.	PARTS CODE	PRICE RANK	NEW MARK	PART DELIVERY	DESCRIPTION
<b>[4] DUNTKF282FM06/07/11 (MAIN Unit)</b>					
R8001	VRS-CZ1JF101JY	AA		J	Resistor 100 1/16W Metal Oxide
R8002	VRS-CZ1JF103JY	AA		J	Resistor 10k 1/16W Metal Oxide
R8003	VRS-CZ1JF101FY	AA		J	Resistor 100 1/16W Metal Oxide
R8004	VRS-CZ1JF390FY	AA		J	Resistor 39 1/16W Metal Oxide
R8005	VRS-CZ1JF512FY	AA		J	Resistor 5.1k 1/16W Metal Oxide
R8006	VRS-CZ1JF000JY	AA		J	Resistor 0 1/16W Metal Oxide
R8007	VRS-CZ1JF000JY	AA		J	Resistor 0 1/16W Metal Oxide
R8008	VRS-CZ1JF561JY	AA		J	Resistor 560 1/16W Metal Oxide
R8009	VRS-CZ1JF472JY	AA		J	Resistor 4.7k 1/16W Metal Oxide
R8010	VRS-CZ1JF000JY	AA		J	Resistor 0 1/16W Metal Oxide
R8011	VRS-CZ1JF105JY	AA		J	Resistor 1M 1/16W Metal Oxide
R8012	VRS-CZ1JF000JY	AA		J	Resistor 0 1/16W Metal Oxide
R8013	VRS-CZ1JF000JY	AA		J	Resistor 0 1/16W Metal Oxide
R8016	VRS-CZ1JF000JY	AA		J	Resistor 0 1/16W Metal Oxide
R8018	VRS-CZ1JF000JY	AA		J	Resistor 0 1/16W Metal Oxide
R8020	VRS-CZ1JF000JY	AA		J	Resistor 0 1/16W Metal Oxide
R8024	VRS-CZ1JF560JY	AA		J	Resistor 56 1/16W Metal Oxide
R8025	VRS-CZ1JF560JY	AA		J	Resistor 56 1/16W Metal Oxide
R8026	VRS-CZ1JF560JY	AA		J	Resistor 56 1/16W Metal Oxide
R8027	VRS-CZ1JF560JY	AA		J	Resistor 56 1/16W Metal Oxide
R8028	VRS-CZ1JF560JY	AA		J	Resistor 56 1/16W Metal Oxide
R8029	VRS-CZ1JF560JY	AA		J	Resistor 56 1/16W Metal Oxide
R8031	VRS-CZ1JF303JY	AA		J	Resistor 30k 1/16W Metal Oxide
R8032	VRS-CZ1JF303JY	AA		J	Resistor 30k 1/16W Metal Oxide
R8033	VRS-CZ1JF303JY	AA		J	Resistor 30k 1/16W Metal Oxide
R8034	VRS-CZ1JF303JY	AA		J	Resistor 30k 1/16W Metal Oxide
R8035	VRS-CZ1JF303JY	AA		J	Resistor 30k 1/16W Metal Oxide
R8036	VRS-CZ1JF303JY	AA		J	Resistor 30k 1/16W Metal Oxide
R8037	VRS-CZ1JF303JY	AA		J	Resistor 30k 1/16W Metal Oxide
R8038	VRS-CZ1JF303JY	AA		J	Resistor 30k 1/16W Metal Oxide
R8039	VRS-CZ1JF102JY	AA		J	Resistor 1k 1/16W Metal Oxide
R8046	VRS-CZ1JF472JY	AA		J	Resistor 4.7k 1/16W Metal Oxide
R8047	VRS-CZ1JF472JY	AA		J	Resistor 4.7k 1/16W Metal Oxide
R8048	VRS-CZ1JF472JY	AA		J	Resistor 4.7k 1/16W Metal Oxide
R8049	VRS-CZ1JF472JY	AA		J	Resistor 4.7k 1/16W Metal Oxide
R8051	VRS-CZ1JF472JY	AA		J	Resistor 4.7k 1/16W Metal Oxide
R8052	VRS-CZ1JF472JY	AA		J	Resistor 4.7k 1/16W Metal Oxide
R8054	VRS-CZ1JF103JY	AA		J	Resistor 10k 1/16W Metal Oxide
R8056	VRS-CZ1JF472JY	AA		J	Resistor 4.7k 1/16W Metal Oxide
R8058	VRS-CZ1JF472JY	AA		J	Resistor 4.7k 1/16W Metal Oxide
R8060	VRS-CZ1JF472JY	AA		J	Resistor 4.7k 1/16W Metal Oxide
R8061	VRS-CZ1JF472FY	AA		J	Resistor 4.7k 1/16W Metal Oxide
R8062	VRS-CZ1JF472FY	AA		J	Resistor 4.7k 1/16W Metal Oxide
R8063	VRS-CZ1JF472JY	AA		J	Resistor 4.7k 1/16W Metal Oxide
R8065	VRS-CZ1JF330JY	AA		J	Resistor 33 1/16W Metal Oxide
R8072	VRS-CZ1JF180JY	AA		J	Resistor 18 1/16W Metal Oxide
R8073	VRS-CZ1JF180JY	AA		J	Resistor 18 1/16W Metal Oxide
R8074	VRS-CZ1JF180JY	AA		J	Resistor 18 1/16W Metal Oxide
R8075	VRS-CZ1JF180JY	AA		J	Resistor 18 1/16W Metal Oxide
R8076	VRS-CZ1JF180JY	AA		J	Resistor 18 1/16W Metal Oxide
R8077	VRS-CZ1JF180JY	AA		J	Resistor 18 1/16W Metal Oxide
R8079	VRS-CZ1JF750JY	AA		J	Resistor 75 1/16W Metal Oxide
R8151	VRS-CZ1JF000JY	AA		J	Resistor 0 1/16W Metal Oxide
R8152	VRS-CZ1JF000JY	AA		J	Resistor 0 1/16W Metal Oxide
R8153	VRS-CZ1JF000JY	AA		J	Resistor 0 1/16W Metal Oxide
R8154	VRS-CZ1JF000JY	AA		J	Resistor 0 1/16W Metal Oxide
R8157	VRS-CZ1JF101JY	AA		J	Resistor 100 1/16W Metal Oxide
R8158	VRS-CZ1JF101JY	AA		J	Resistor 100 1/16W Metal Oxide
R8181	VRS-CG1JF100JY	AA		J	Resistor 10 1/16W Metal Oxide
R8182	VRS-CG1JF100JY	AA		J	Resistor 10 1/16W Metal Oxide
R8183	VRS-CG1JF100JY	AA		J	Resistor 10 1/16W Metal Oxide
R8184	VRS-CG1JF100JY	AA		J	Resistor 10 1/16W Metal Oxide
R8185	VRS-CG1JF100JY	AA		J	Resistor 10 1/16W Metal Oxide
R8186	VRS-CG1JF100JY	AA		J	Resistor 10 1/16W Metal Oxide
R8451	VRS-CZ1JF470JY	AA		J	Resistor 47 1/16W Metal Oxide
R8453	VRS-CZ1JF472FY	AA		J	Resistor 4.7k 1/16W Metal Oxide
R8455	VRS-CZ1JF472FY	AA		J	Resistor 4.7k 1/16W Metal Oxide
R8458	VRS-CH1JF000JY	AA		J	Resistor 0 1/16W Metal Oxide
R8459	VRS-CH1JF000JY	AA		J	Resistor 0 1/16W Metal Oxide
R8462	VRS-CZ1JF000JY	AA		J	Resistor 0 1/16W Metal Oxide
R8463	VRS-CZ1JF000JY	AA		J	Resistor 0 1/16W Metal Oxide
R8474	VRS-CZ1JF470JY	AA		J	Resistor 47 1/16W Metal Oxide
R8475	VRS-CZ1JF470JY	AA		J	Resistor 47 1/16W Metal Oxide
R9001	VRS-TV1JD101JY	AA		J	Resistor 100 1/10W Metal Oxide
R9002	VRS-CZ1JF103JY	AA		J	Resistor 10k 1/16W Metal Oxide
R9004	VRS-CZ1JF182JY	AA		J	Resistor 1.8k 1/16W Metal Oxide
R9008	VRS-CZ1JF472JY	AA		J	Resistor 4.7k 1/16W Metal Oxide
R9009	VRS-CZ1JF472JY	AA		J	Resistor 4.7k 1/16W Metal Oxide
R9010	VRS-CZ1JF182JY	AA		J	Resistor 1.8k 1/16W Metal Oxide
R9011	VRS-CZ1JF182JY	AA		J	Resistor 1.8k 1/16W Metal Oxide
R9012	VRS-CZ1JF182JY	AA		J	Resistor 1.8k 1/16W Metal Oxide
R9013	VRS-CG1JF472JY	AA		J	Resistor 4.7k 1/16W Metal Oxide
R9014	VRS-CZ1JF103JY	AA		J	Resistor 10k 1/16W Metal Oxide
R9015	VRS-CZ1JF103JY	AA		J	Resistor 10k 1/16W Metal Oxide
R9018	VRS-CZ1JF103JY	AA		J	Resistor 10k 1/16W Metal Oxide

NO.	PARTS CODE	PRICE RANK	NEW MARK	PART DELIVERY	DESCRIPTION
<b>[4] DUNTKF282FM06/07/11 (MAIN Unit)</b>					
R9020	VRS-TV1JD101JY	AA		J	Resistor 100 1/10W Metal Oxide
R9021	VRS-TV1JD101JY	AA		J	Resistor 100 1/10W Metal Oxide
R9023	VRS-CZ1JF000JY	AA		J	Resistor 0 1/16W Metal Oxide
R9025	VRS-CZ1JF472JY	AA		J	Resistor 4.7k 1/16W Metal Oxide
R9026	VRS-CZ1JF472JY	AA		J	Resistor 4.7k 1/16W Metal Oxide
R9027	VRS-CZ1JF472JY	AA		J	Resistor 4.7k 1/16W Metal Oxide
R9028	VRS-CZ1JF472JY	AA		J	Resistor 4.7k 1/16W Metal Oxide
R9301	VRS-CZ1JF473JY	AA		J	Resistor 47k 1/16W Metal Oxide
R9302	VRS-CZ1JF332JY	AA		J	Resistor 3.3k 1/16W Metal Oxide
R9305	VRS-CZ1JF472JY	AA		J	Resistor 4.7k 1/16W Metal Oxide
R9308	VRS-CZ1JF472JY	AA		J	Resistor 4.7k 1/16W Metal Oxide
R9319	VRS-CZ1JF472JY	AA		J	Resistor 4.7k 1/16W Metal Oxide
R9326	VRS-CZ1JF102JY	AA		J	Resistor 1k 1/16W Metal Oxide
R9601	VRS-CZ1JF103FY	AB		J	Resistor 10k 1/16W Metal Oxide
R9603	VRS-CZ1JF272FY	AA		J	Resistor 2.7k 1/16W Metal Oxide
R9605	VRS-CZ1JF562JY	AA		J	Resistor 5.6k 1/16W Metal Oxide
R9606	VRS-CZ1JF390JY	AA		J	Resistor 39 1/16W Metal Oxide
R9607	VRS-CZ1JF471JY	AA		J	Resistor 470 1/16W Metal Oxide
R9608	VRS-CZ1JF472JY	AA		J	Resistor 4.7k 1/16W Metal Oxide
R9609	VRS-CZ1JF222JY	AA		J	Resistor 2.2k 1/16W Metal Oxide
R9610	VRS-CZ1JF682JY	AA		J	Resistor 6.8k 1/16W Metal Oxide
R9611	VRS-CZ1JF473FY	AA		J	Resistor 47k 1/16W Metal Oxide
R9612	VRS-CZ1JF472JY	AA		J	Resistor 4.7k 1/16W Metal Oxide
R9613	VRS-CZ1JF103FY	AB		J	Resistor 10k 1/16W Metal Oxide
R9614	VRS-CZ1JF103FY	AB		J	Resistor 10k 1/16W Metal Oxide
R9616	VRS-CZ1JF123FY	AA		J	Resistor 12k 1/16W Metal Oxide
R9617	VRS-CZ1JF561JY	AA		J	Resistor 560 1/16W Metal Oxide
R9618	VRS-CZ1JF272FY	AA		J	Resistor 2.7k 1/16W Metal Oxide
R9619	VRS-CZ1JF472JY	AA		J	Resistor 4.7k 1/16W Metal Oxide
R9622	VRS-CZ1JF103FY	AB		J	Resistor 10k 1/16W Metal Oxide
R9623	VRS-CZ1JF273FY	AA		J	Resistor 27k 1/16W Metal Oxide
R9624	VRS-CZ1JF472JY	AA		J	Resistor 4.7k 1/16W Metal Oxide
R9625	VRS-CZ1JF103FY	AB		J	Resistor 10k 1/16W Metal Oxide
R9629	VRS-CZ1JF390JY	AA		J	Resistor 39 1/16W Metal Oxide
R9630	VRS-TW2HF1R0JY	AA		J	Resistor 1 1/2W Metal Oxide
R9631	VRS-TW2HF1R0JY	AA		J	Resistor 1 1/2W Metal Oxide
R9633	VRS-CZ1JF390JY	AA		J	Resistor 39 1/16W Metal Oxide
R9634	VRS-CZ1JF4R7JY	AA		J	Resistor 4.7 1/16W Metal Oxide
R9701	VRS-CZ1JF223JY	AA		J	Resistor 22k 1/16W Metal Oxide
R9702	VRS-CZ1JF103JY	AA		J	Resistor 10k 1/16W Metal Oxide
R9703	VRS-CZ1JF103JY	AA		J	Resistor 10k 1/16W Metal Oxide
R9704	VRS-CZ1JF472JY	AA		J	Resistor 4.7k 1/16W Metal Oxide
R9705	VRS-CZ1JF102JY	AA		J	Resistor 1k 1/16W Metal Oxide
R9706	VRS-CZ1JF150JY	AA		J	Resistor 15 1/16W Metal Oxide
R9707	VRS-CZ1JF153JY	AA		J	Resistor 15k 1/16W Metal Oxide
R9708	VRS-CZ1JF103FY	AB		J	Resistor 10k 1/16W Metal Oxide
R9709	VRS-CZ1JF472JY	AA		J	Resistor 4.7k 1/16W Metal Oxide
R9710	VRS-CZ1JF102JY	AA		J	Resistor 1k 1/16W Metal Oxide
R9711	VRS-CZ1JF102JY	AA		J	Resistor 1k 1/16W Metal Oxide
R9736	VRS-CZ1JF103JY	AA		J	Resistor 10k 1/16W Metal Oxide
R9740	VRS-CZ1JF273JY	AA		J	Resistor 27k 1/16W Metal Oxide
R9741	VRS-CZ1JF473JY	AA		J	Resistor 47k 1/16W Metal Oxide
R9744	VRS-CZ1JF222JY	AA		J	Resistor 2.2k 1/16W Metal Oxide
R9745	VRS-CZ1JF472JY	AA		J	Resistor 4.7k 1/16W Metal Oxide
R9746	VRS-CY1JF000JY	AA		J	Resistor 0 1/16W Metal Oxide
RDA8001	PRDARA795WJFW	AK		X	Heat Sink
SC1601	QSOCZA149WJQZY	AF		J	Socket 23Pin
SC1602	QSOCZA171WJZZY	AF		J	Socket 23Pin
SC1801	QSOCZA171WJZZY	AF		J	Socket 23Pin
SC1802	QSOCZA171WJZZY	AF		J	Socket 23Pin
SC1804	QSOCNA816WJZZ	AG		X	Socket 17Pin
SC9001	QSOCNA818WJZZ	AH		X	Socket 11Pin
TH2001	VHHM1103J03-1Y	AC		J	Thermistor
TU1102	RTUDAA043WJQZ	AZ		X	Tuner
VA8001	RH-VXA074WJZZY	AB		J	Varistor AVRL101A1R1NTB
VA8002	RH-VXA074WJZZY	AB		J	Varistor AVRL101A1R1NTB
X2002	RFILZA023WJQZY	AD		J	Crystal Filter
X8001	RCRSCA205WJQZY	AD		J	Crystal
N	PSPAZC305WJKZ			X	Spacer
<b>[5] DUNTKF096FM01 (R/C, LED Unit)</b>					
C101	VCKYCY1HF103ZY	AA		J	Capacitor 0.01 50V Ceramic
C102	VCEASX1CN106MY	AC		J	Capacitor 10 16V Electrolytic
C103	VCEASY1CN107MY	AC		J	Capacitor 100 16V Electrolytic
C104	VCKYTV1CF225ZY	AB		J	Capacitor 2.2 16V Ceramic
D102	RH-PX0421CEZZY	AD		J	Diode CL-165HR/YG-D-T
D103	RH-PX0421CEZZY	AD		J	Diode CL-165HR/YG-D-T
D104	RH-EXA092WJZZY	AB		J	Diode UDZSFVTE-1712B
IC101	VHIGA1S100W-1Y	AE		J	IC GA1A1S100WP
P102	QPLGNA330WJZZY	AD		J	Plug 10Pin (RA)
Q102	VS2SC3928AR-1Y	AB		J	Transistor 2SC3928A-T112-1R
Q103	VS2SC3928AR-1Y	AB		J	Transistor 2SC3928A-T112-1R
Q104	VS2SC3928AR-1Y	AB		J	Transistor 2SC3928A-T112-1R
Q105	VS2SC3928AR-1Y	AB		J	Transistor 2SC3928A-T112-1R
R103	VRS-CY1JF161JY	AA		J	Resistor 160 1/16W Metal Oxide

NO.	PARTS CODE	PRICE RANK	NEW MARK	PART DELIVERY	DESCRIPTION
<b>[5] DUNTKF096FM01 (R/C, LED Unit)</b>					
R105	VRS-CJ1JF103JY	AA		J	Resistor 10k 1/16W Metal Oxide
R106	VRS-CY1JF223JY	AA		J	Resistor 22k 1/16W Metal Oxide
R107	VRS-CY1JF393JY	AA		J	Resistor 39k 1/16W Metal Oxide
R110	VRS-CY1JF103JY	AA		J	Resistor 10k 1/16W Metal Oxide
R113	VRS-CY1JF000JY	AA		J	Resistor 0 1/16W Metal Oxide
R114	VRS-CY1JF161JY	AA		J	Resistor 160 1/16W Metal Oxide
R115	VRS-CY1JF821JY	AA		J	Resistor 820 1/16W Metal Oxide
R116	VRS-CY1JF273JY	AA		J	Resistor 27k 1/16W Metal Oxide
R120	VRS-CY1JF101JY	AA		J	Resistor 100 1/16W Metal Oxide
RMC101	RRMUA053WJZZ	AE		J	Remote Receiver
SLD101	PSLDPA076WJFW	AD		J	Case Shield
<b>[6] DUNTKE266FM02 (KEY Unit)</b>					
D151	RH-EX0646GEZZY	AA		J	Diode MTZJT-7215B
D152	RH-EX0646GEZZY	AA		J	Diode MTZJT-7215B
D155	RH-EX0646GEZZY	AA		J	Diode MTZJT-7215B
P151	QPLGNA059WJZZ	AC		J	Plug 5Pin (KM)
R151	VRD-RA2BE822JY	AA		J	Resistor 8.2k 1/8W Carbon
R152	VRD-RA2BE123JY	AA		J	Resistor 12k 1/8W Carbon
R153	VRD-RA2BE822JY	AA		J	Resistor 8.2k 1/8W Carbon
R154	VRD-RA2BE123JY	AA		J	Resistor 12k 1/8W Carbon
S151	QSW-K0003AJZZ+	AB		J	Switch CH-UP
S152	QSW-K0003AJZZ+	AB		J	Switch CH-DOWN
S153	QSW-K0003AJZZ+	AB		J	Switch INPUT
S154	QSW-K0003AJZZ+	AB		J	Switch VOL-UP
S155	QSW-K0003AJZZ+	AB		J	Switch VOL-DOWN
S156	QSW-K0003AJZZ+	AB		J	Switch MENU
S157	QSW-K0003AJZZ+	AB		J	Switch POWER

[7] CABINET PARTS (LC-60E77UN/C6077UN)

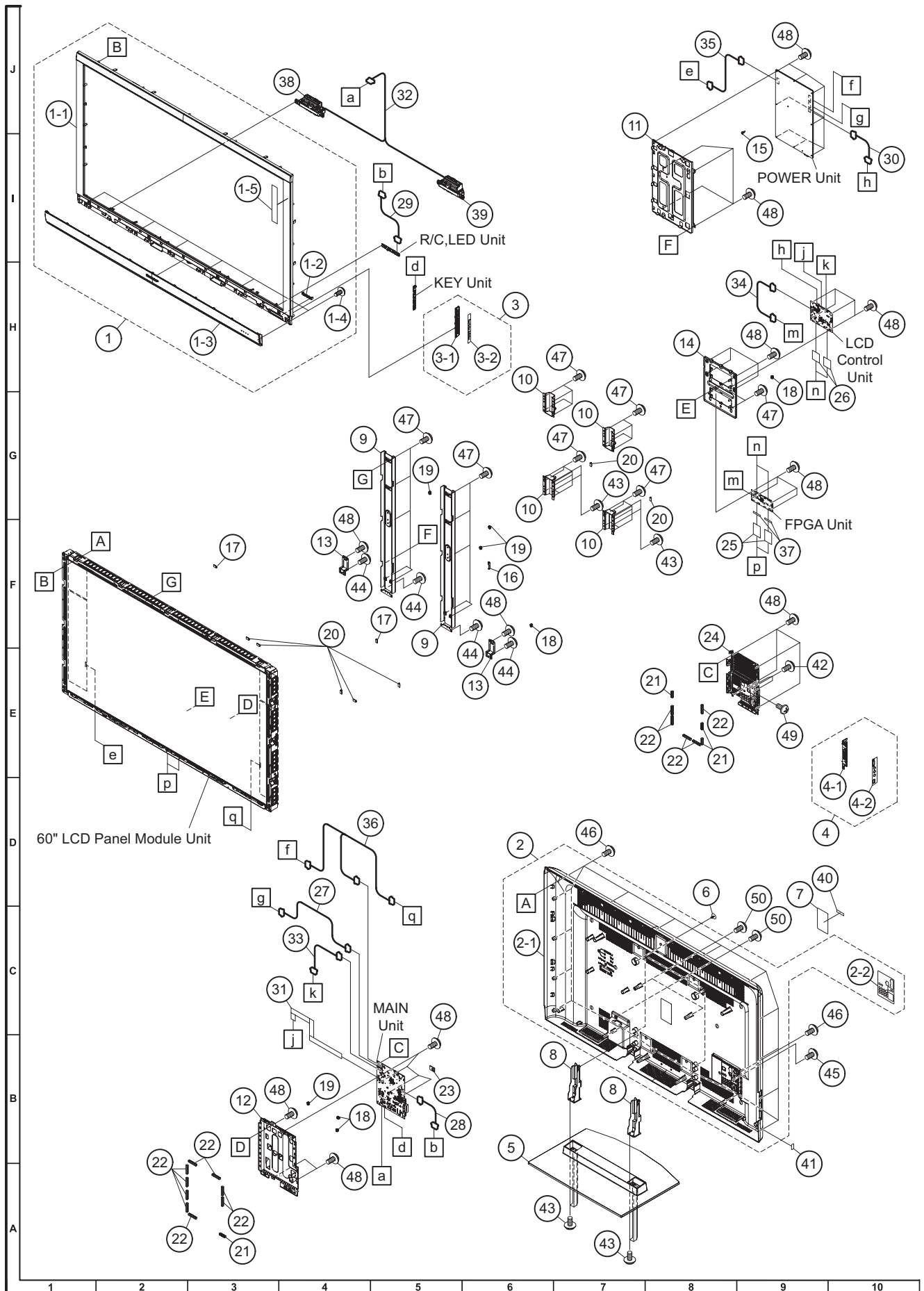

NO.	PARTS CODE	PRICE RANK	NEW MARK	PART DELIVERY	DESCRIPTION
<b>[7] CABINET PARTS (LC-60E77UN/C6077UN)</b>					
1	CCABAC403WJ31	BP	N	X	Front Cabinet Ass'y (LC-60E77UN)
1	CCABAC403WJ33		N	X	Front Cabinet Ass'y (LC-C6077UN)
1-1	Not Available	-	N	-	Front Cabinet
1-2	Not Available	-	-	-	LED Cover
1-3	Not Available	-	N	-	Front Decoration (LC-60E77UN)
1-3	Not Available	-	N	-	Front Decoration (LC-C6077UN)
1-4	XEBS740P10000	AB		J	Screw, x6
1-5	TLABZC260WJN1	AE		X	POP Label
2	CCABBB623WJ31	BN	N	X	Rear Cabinet Ass'y
2-1	Not Available	-	N	-	Rear Cabinet
2-2	HINDPD461WJSA	AD	N	X	Terminal Label
3	CCOVAC952WJ01	AF		X	KEY Button Cover Ass'y
3-1	Not Available	-	N	-	KEY Button Cover
3-2	Not Available	-	N	-	Control Button Cover
4	CCOVAC951WJ02	AF	N	X	Side Terminal Cover Ass'y
4-1	Not Available	-	N	-	Side Terminal Cover
4-2	Not Available	-	N	-	Side Terminal Label
5	CDAi-A582WJ02	BE	N	X	Stand Unit
6	GCOVAC576WJKZ	AC		J	VESA Cover, x4
7	HINDPD458WJSA	AB	N	X	Model Label (LC-60E77UN)
7	HINDPD513WJSA	AB	N	X	Model Label (LC-C6077UN)
8	LANGFA678WJFW	AH	N	X	Stand Support, x2
9	LANGKC425WJFW	AN	N	X	Support Angle, x2
10	LANGKC426WJM1	AG	N	X	VESA Angle, x4
11	LANGKC427WJFW	AK	N	X	POWER PWB Angle
12	LANGKC428WJFW	AK	N	X	MAIN PWB Angle
13	LANGKC429WJFW	AC	N	X	Panel Lug, x2
14	LANGKC430WJFW	AG	N	X	Control PWB Angle
15	LHLDFA028WJKZ	AC		J	POWER PWB Spacer
16	LHLDWA074WJKZ	AD		J	Wire Holder
17	LHLDWA133WJKZ	AC		J	Wire Holder, x2
18	LHLDWA143WJKZ	AC		J	Wire Holder, x4
19	LHLDWA151WJKZ	AB		J	Wire Holder, x4
20	LHLDWA175WJUJ	AC		J	Wire Holder, x7
21	PMLT-A593WJZZ	AC		X	Gasket (8x35x7t), x4
22	PMLT-A594WJZZ	AD		X	Gasket (8x50x7t), x14
23	PMLT-A597WJQZ	AF		X	Gasket (Tuner)
24	PSLDMB629WJFW	AM		X	MAIN PWB Shield
25	QCNW-H089WJQZ	AG	N	J	Connecting Cord (FFC2), x2
26	QCNW-J071WJQZ	AF	N	J	Connecting Cord (FFC1), x2
27	QCNW-J810WJQZ	AG	N	X	Connecting Cord (PD)
28	QCNW-J812WJQZ	AD	N	X	Connecting Cord (KM)
29	QCNW-J813WJQZ	AF	N	X	Connecting Cord (RA)
30	QCNW-J814WJQZ	AD	N	X	Connecting Cord (PL)
31	QCNW-J815WJQZ	AU	N	X	Connecting Cord (LW)
32	QCNW-J816WJPZ	AG	N	X	Connecting Cord (SP)
33	QCNW-J817WJQZ	AF	N	X	Connecting Cord (LP)
34	QCNW-J925WJQZ	AF	N	X	Connecting Cord
35	QCNW-K069WJQZ	AG	N	X	Connecting Cord (LA2)
36	QCNW-K070WJQZ	AM	N	X	Connecting Cord (LA)
37	RCORFA061WJZZ	AG		J	Core, x2
38	RSP-ZA391WJZZ	AP		J	Speaker-L
39	RSP-ZA392WJZZ	AP		J	Speaker-R
40	Not Available	-	-	-	Back Serial Label
41	Not Available	-	N	-	Side Serial Label
42	XBPS830P06000	AA		J	Screw (for HDMI), x3
43	XBPS950P12KS0	AA		X	Screw (for Stand), x14
44	XEBS740P10000	AB		J	Screw (for PANEL-Front Cabinet), x4
45	XEBS930P10000	AA		J	Screw (for S-Video)
46	XEBS940P16000	AB		J	Screw (for Rear Cabinet), x18
47	XHBS840P08000	AA	N	X	Screw (for BL/VESA), x32
48	XHPS830P06WS0	AA		J	Screw (for Chassis), x37
49	XIPSN20P04000	AA		J	Screw (for Side HDMI), x2
50	XHPS830P10WS0	AA		J	Screw (for Chassis), x3

**[8] LCD PANEL MODULE Assembly (LC-60E77UN/C6077UN)**

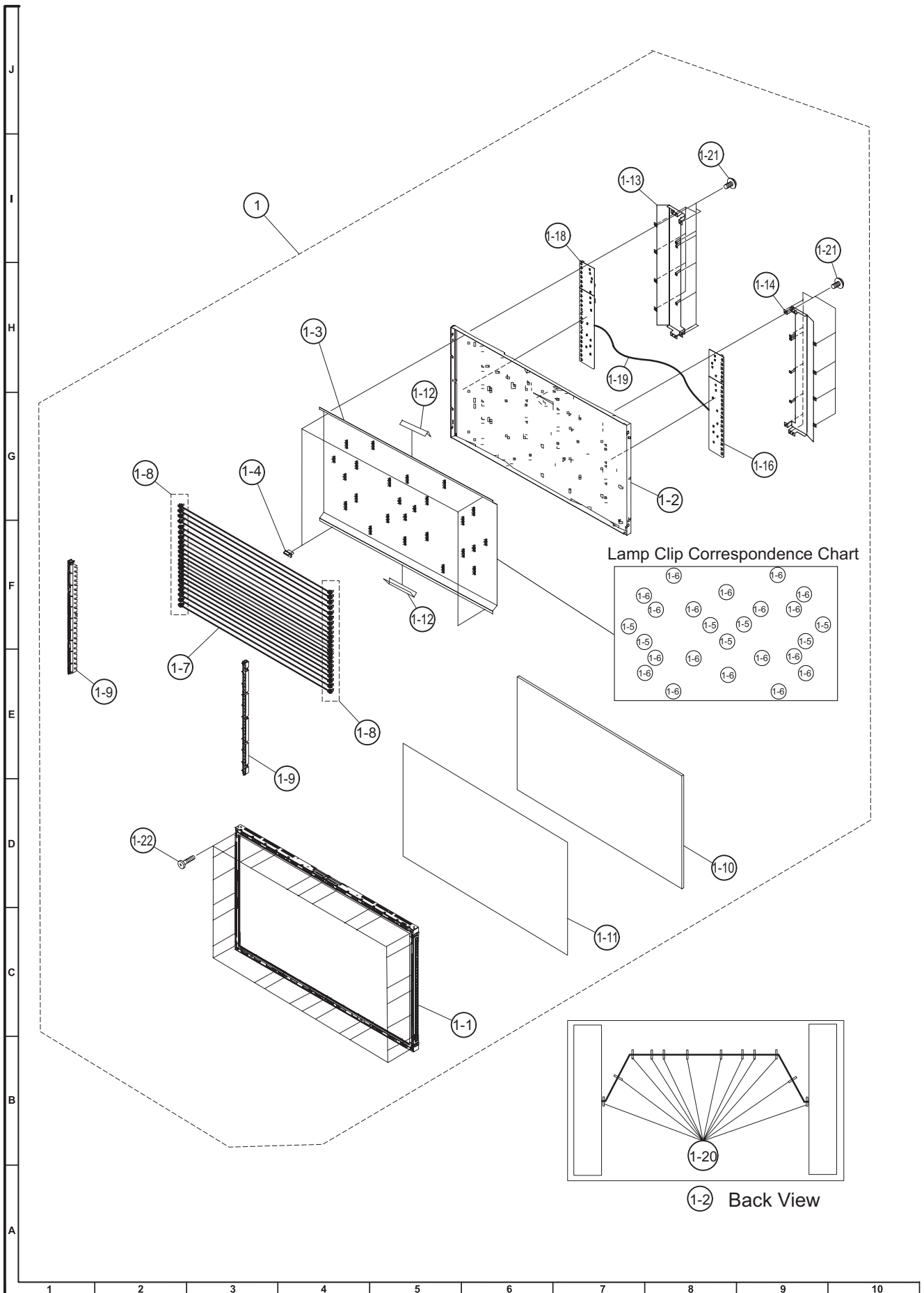

NO.	PARTS CODE	PRICE RANK	NEW MARK	PART DELIVERY	DESCRIPTION
<b>[8] LCD PANEL MODULE Assembly (LC-60E77UN/C6077UN)</b>					
1	R1LK600D3GW10Z	ER	N	X	60" LCD Panel Module Unit
1-1	Not Available	-		-	Bezel Ass'y
1-2	CCHSM0074TP02	BQ		X	BL Chassis Ass'y
1-3	PREFL2819TPZZ	AX		X	Reflector Sheet
1-4	LHLDZA963WJKZ	AA		X	Holder, x4
1-5	LHLDZ4187TPZZ	AA		X	Lamp Clip, x7
1-6	LHLDZ4188TPZZ	AA		X	Lamp Clip, x18
1-7	RLMP-0755TPZZ	AP		X	Lamp, x22
1-8	QSOFC0008TPZZ	AD		X	Socket, x44
1-9	LHLDZ4185TPZZ	AH		X	Lamp Holder, x2
1-10	PSLDK3150TPZZ	BD		X	Diffusion Plate
1-11	PSLDK3151TPZZ	BB		X	Micro Lens Sheet
1-12	PTPEH1708TPZZ	AB		X	Both - Side Adhesive Tape, x2
1-13	PCOVP2719TPZZ	AL		X	INVERTER Cover-R
1-14	PCOVP2720TPZZ	AL		X	INVERTER Cover-L
1-16	RDENC2613TPZZ	BN		X	INVERTER-1 Unit
1-18	RDENC2615TPZZ	BN		X	INVERTER-2 Unit
1-19	QCWN2391TPZZ	AK		X	Harness
1-20	LHLDWA043WJKZ	AA		X	Harness Holder, x12
1-21	LX-HZ2203TPZZ	AA		X	Screw, x24 (for fixing INVERTER Cover)
1-22	LX-HZA042WJF8	AA		X	Screw, x28 (for fixing Bezel Ass'y)

[9] CABINET PARTS (LC-65E77UM/C6577UM)

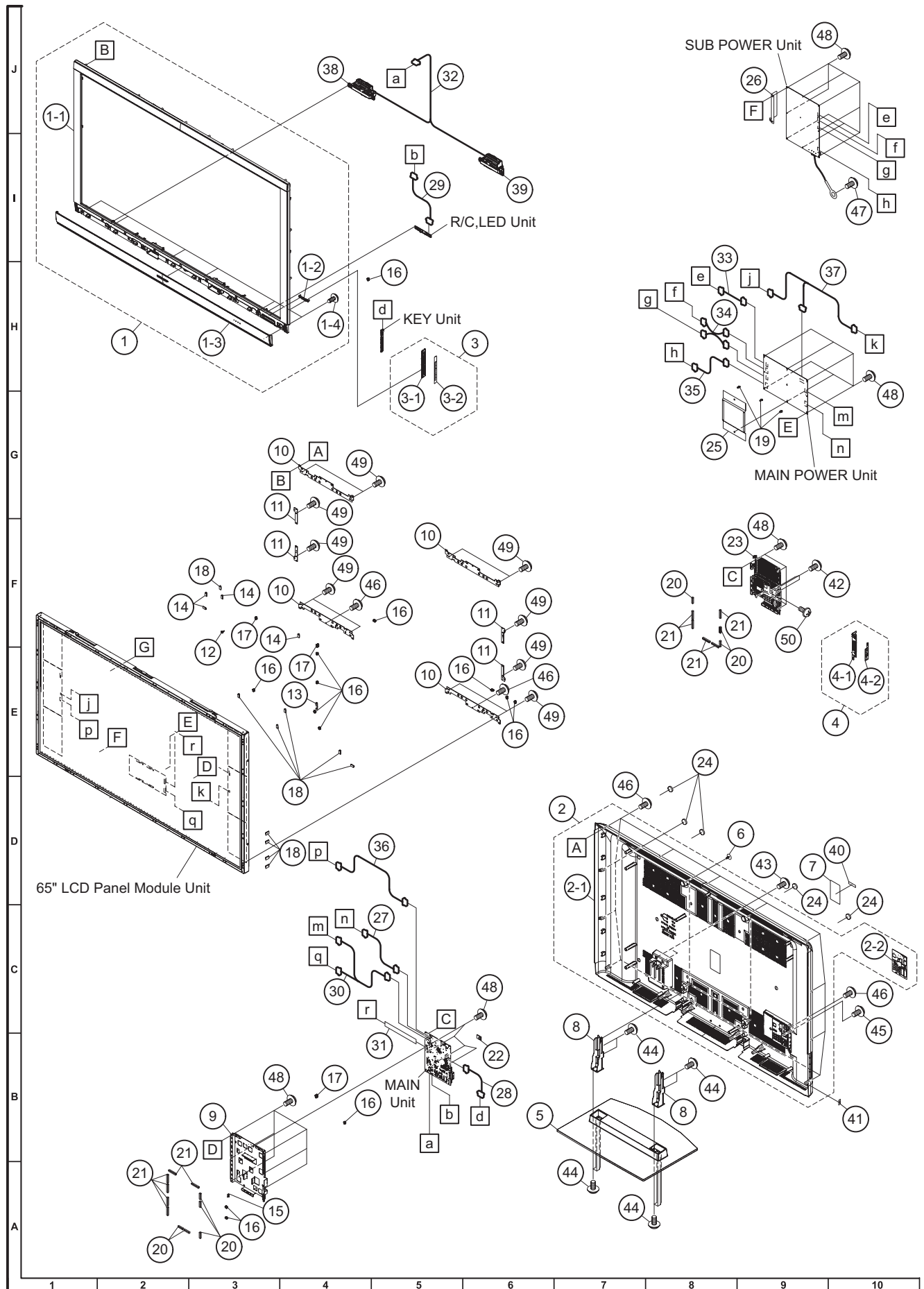

NO.	PARTS CODE	PRICE RANK	NEW MARK	PART DELIVERY	DESCRIPTION
<b>[9] CABINET PARTS (LC-65E77UM/C6577UM)</b>					
1	CCABAC404WJ31	BN	N	X	Front Cabinet Ass'y (LC-65E77UM)
1	CCABAC404WJ32	BN	N	X	Front Cabinet Ass'y (LC-C6577UM)
1-1	Not Available	-	N	-	Front Cabinet
1-2	Not Available	-	-	-	LED Cover
1-3	Not Available	-	N	-	Front Decoration (LC-65E77UM)
1-3	Not Available	-	N	-	Front Decoration (LC-C6577UM)
1-4	XEBS740P10000	AB	-	J	Screw, x4
2	CCABBB624WJ31	BN	N	X	Rear Cabinet Ass'y
2-1	Not Available	-	N	-	Rear Cabinet
2-2	HINDPD461WJSA	AD	-	X	Terminal Label
3	CCOVAC952WJ01	AF	-	X	KEY Button Cover Ass'y
3-1	Not Available	-	N	-	KEY Button Cover
3-2	Not Available	-	N	-	Control Button Cover
4	CCOVAC951WJ02	AF	N	X	Side Terminal Cover Ass'y
4-1	Not Available	-	N	-	Side Terminal Cover
4-2	Not Available	-	N	-	Side Terminal Label
5	CDAi-A582WJ01	BE	N	X	Stand Unit
6	GCOVAC531WJUJ	AA	-	X	VESA Cover, x4
7	HINDPD471WJSA	AB	N	X	Model Label (LC-65E77UM)
7	HINDPD509WJSA	AB	N	X	Model Label (LC-C6577UM)
8	LANGFA678WJFW	AH	N	X	Stand Support, x2
9	LANGKC436WJFW	AK	N	X	MAIN PWB Angle
10	LANGKC438WJFW	AE	N	X	Corner Lug, x4
11	LANGKC439WJFW	AB	N	X	Side Lug, x4
12	LHLDFA036WJKZ	AB	-	J	Wire Holder (PWB Holder)
13	LHLDWA074WJKZ	AD	-	J	Wire Holder
14	LHLDWA133WJKZ	AC	-	J	Wire Holder, x4
15	LHLDWA135WJKZ	AB	-	J	Wire Holder
16	LHLDWA143WJKZ	AC	-	J	Wire Holder, x13
17	LHLDWA151WJKZ	AB	-	J	Wire Holder, x3
18	LHLDWA175WJUJ	AC	-	J	Wire Holder, x9
19	LHLDZA587WJKZ	AC	-	J	Spacer (for POWER), x3
20	PMLT-A593WJZZ	AC	-	X	Gasket (8x35x7t), x8
21	PMLT-A594WJZZ	AD	-	X	Gasket (8x50x7t), x11
22	PMLT-A597WJQZ	AF	-	X	Gasket (Tuner)
23	PSLDMB629WJFW	AM	-	X	MAIN PWB Shield
24	PSPAGA386WJ00	AA	-	X	Spacer, x5
25	PZETJA005WJKA	AF	N	X	POWER 2 Barrier
26	PZETJA006WJKA	AC	N	X	POWER 1 Barrier
27	QCNW-J818WJQZ	AE	N	X	Connecting Cord (PD)
28	QCNW-J820WJQZ	AE	N	X	Connecting Cord (KM)
29	QCNW-J821WJQZ	AF	N	X	Connecting Cord (RA)
30	QCNW-J822WJQZ	AM	N	X	Connecting Cord (PL)
31	QCNW-J823WJQZ	AQ	N	X	Connecting Cord (LW)
32	QCNW-J824WJQZ	AG	N	X	Connecting Cord (SP)
33	QCNW-K073WJQZ	AG	N	X	Connecting Cord (PP1)
34	QCNW-K074WJQZ	AP	N	X	Connecting Cord (PP2)
35	QCNW-K075WJQZ	AH	N	X	Connecting Cord (PQ)
36	QCNW-K077WJQZ	AG	N	X	Connecting Cord (LB)
37	QCNW-K106WJQZ	AM	N	X	Connecting Cord
38	RSP-ZA391WJZZ	AP	-	J	Speaker-L
39	RSP-ZA392WJZZ	AP	-	J	Speaker-R
40	Not Available	-	-	-	Back Serial Label
41	Not Available	-	N	-	Side Serial Label
42	XBPS830P06000	AA	-	J	Screw (for HDMI), x3
43	XBPS930P08JS0	AB	-	J	Screw (for AC-INVERTER), x2
44	XBPS950P12KS0	AA	-	X	Screw (for Stand), x14
45	XEBS930P10000	AA	-	J	Screw (for S-Video)
46	XEBS940P16000	AB	-	J	Screw (for Rear Cabinet), x18
47	XHPS740P08JS0	AC	N	J	Screw (for Ground)
48	XHPS830P06WS0	AA	-	J	Screw (for Chassis), x28
49	XHPS840P08WS0	AB	-	J	Screw (for Lug), x12
50	XIPSN20P04000	AA	-	J	Screw (for Side HDMI), x2

[10] LCD PANEL MODULE Assembly (LC-65E77UM/C6577UM)

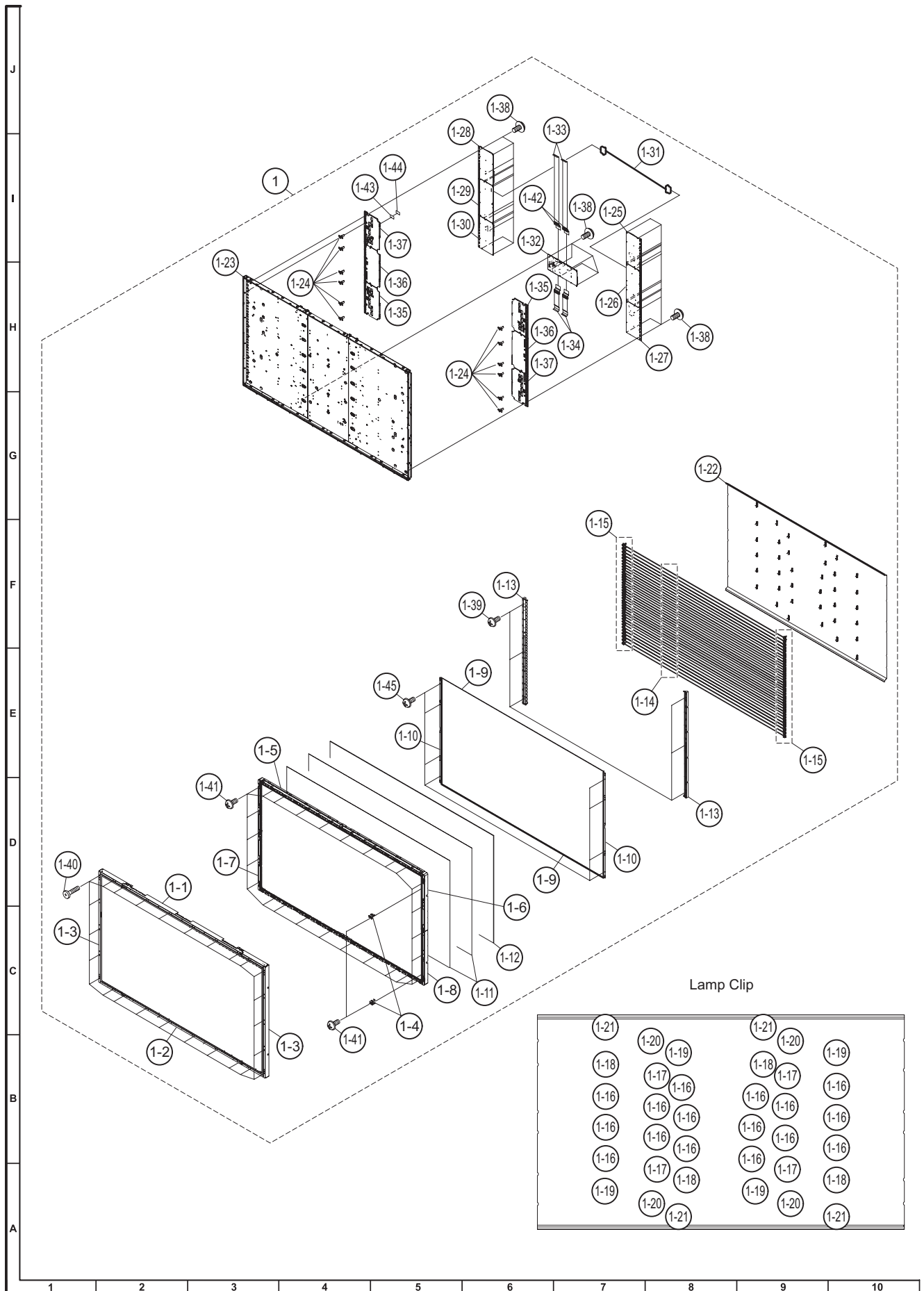

NO.	PARTS CODE	PRICE RANK	NEW MARK	PART DELIVERY	DESCRIPTION
<b>[10] LCD PANEL MODULE Assembly (LC-65E77UM/C6577UM)</b>					
1	R1LK645D3LW20Z	FK	N	X	65"LCD Panel Module Unit (LK645D3LW20Z)
1-1	CANGK4045TP06	AV		X	Bezel Ass'y (Top)
1-2	CANGK4045TP07	AV		X	Bezel Ass'y (Bottom)
1-3	CANGK4044TP03	AX		X	Bezel Ass'y, x2 (L, R)
1-4	CGiDM0004TP01	AB		X	Panel Guide Ass'y, x2
1-5	CHLDZ3789TP01	AP		X	Panel Chassis Ass'y (Top-L)
1-6	CHLDZ3790TP01	AP		X	Panel Chassis Ass'y (Top-R)
1-7	CHLDZ3790TP02	AP		X	Panel Chassis Ass'y (Bottom-L)
1-8	CHLDZ3789TP02	AP		X	Panel Chassis Ass'y (Bottom-R)
1-9	CFiX-0001TP01	AM		X	Sheet Suppression Angle (Top, Bottom), x2
1-10	CFiX-0002TP03	AP		X	Sheet Suppression Angle (L, R), x2
1-11	PSHEPA995WJZZ	BC		X	Lens Sheet, x2
1-12	PCOVUA191WJZZ	BF		X	Diffusion Plate
1-13	LHLDZ3762TPZZ	AK		X	Lamp Holder, x2
1-14	RLMPLA040WJN1	AR		X	Lamp, x36
1-15	QSOCFA007WJZZ	AB		X	Socket, x72
1-16	LHLDZ3769TPZZ	AA		X	Lamp Clip A, x16
1-17	LHLDZ3770TPZZ	AA		X	Lamp Clip B, x4
1-18	LHLDZ3771TPZZ	AA		X	Lamp Clip C, x4
1-19	LHLDZ3772TPZZ	AA		X	Lamp Clip D, x4
1-20	LHLDZ3773TPZZ	AA		X	Lamp Clip E, x4
1-21	LHLDZ3774TPZZ	AA		X	Lamp Clip F, x4
1-22	PMiR-A165WJZZ	BB		X	Reflected Sheet
1-23	CCHSM036TP03	BW		X	BL Chassis Ass'y
1-24	LHLDZA885WJKZ	AA		X	Inverter Spacer, x12
1-25	RUNTKA335WJN1	BE		X	INVERTER-1 Unit
1-26	RUNTKA336WJN1	BB		X	INVERTER-2 Unit
1-27	RUNTKA337WJN1	BE		X	INVERTER-3 Unit
1-28	RUNTKA338WJN1	BE		X	INVERTER-4 Unit
1-29	RUNTKA339WJN1	BG		X	INVERTER-5 Unit
1-30	RUNTKA340WJN1	BE		X	INVERTER-6 Unit
1-31	QCNWN2393TPZZ	AL		X	Harness
1-32	CPWBX4137TPXA	BY		X	LCD Control Unit
1-33	QPWBM0927TPZZ	AT		X	FPC, x2 (Top)
1-34	QPWBM0928TPZZ	AH		X	FPC, x2 (Bottom)
1-35	PCOVWA065WJKZ	AF		X	GKB Cover-1, x2
1-36	PCOVWA066WJKZ	AF		X	GKB Cover-2, x2
1-37	PCOVWA067WJKZ	AF		X	GKB Cover-3, x2
1-38	LX-HZA045WJF7	AA		X	Screw, x34 (for Inverter, x29/LCD Control, x5)
1-39	LX-HZA059WJF7	AA		X	Screw, x6 (for Lamp Holder)
1-40	LX-HZA063WJF8	AA		X	Screw, x26 (for Bezel - BL Chassis)
1-41	LX-HZ2066TPZZ	AA		X	Screw, x28 (for Panel Guide, x2/Bezel - Panel Chassis, x26)
1-42	RCORFA061WJZZ			X	Ferrite Core, x2
1-43	PSPA2C234WJKZ			X	radiator Sheet, x2 (White)
1-44	PSPA2C305WJKZ			X	radiator Sheet, x2 (Pink)
1-45	LX-HZA053WJF7			X	Screw, x8 (for Sheet Suppression Angle (L, R))

**[11] SUPPLIED ACCESSORIES**

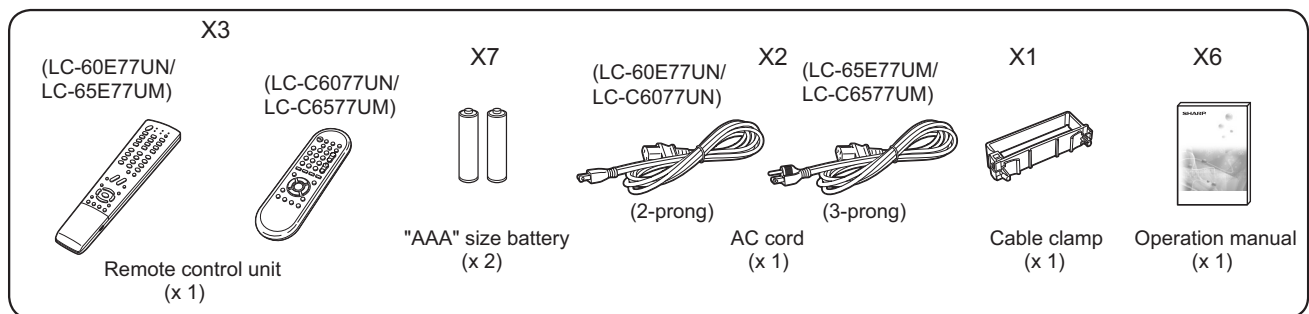

NO.	PARTS CODE	PRICE RANK	NEW MARK	PART DELIVERY	DESCRIPTION
<b>[11] SUPPLIED ACCESSORIES</b>					
X1	LHLDWA168WJZZ	AE	N	J	Cable clamp
X2	QACCD A072WJPZ	AM	N	X	AC Cord (LC-60E77UN/C6077UN)
X2	QACCD A057WJPZ	AV		J	AC Cord (LC-65E77UM/C6577UM)
X3	RRMCGA759WJSA	AR		X	Remote control Unit (LC-60E77UN/65E77UM)
X3	RRMCGA667WJSA	AH		X	Remote control Unit (LC-C6077UN/C6577UM)
X4	TCADEA243WJZZ	AB		X	Enquete Card
X5	TGAN-A845WJN1	AB		X	Extend warranty
X6	TINS-E339WJZZ	AH	N	X	Operation manual (LC-60E77UN/65E77UM)
X6	TINS-E444WJZZ	AH	N	X	Operation manual (E) (LC-C6077UN/C6577UM)
X6	TINS-E445WJZZ	AH	N	X	Operation manual (S) (LC-C6077UN/C6577UM)
X7	Not Available	-		-	"AAA" size battery
X8	TCAUHA352WJZZ	AB		X	Caution Card (LC-C6077UN/C6577UM)

[12] PACKING PARTS (NOT REPLACEMENT ITEM)

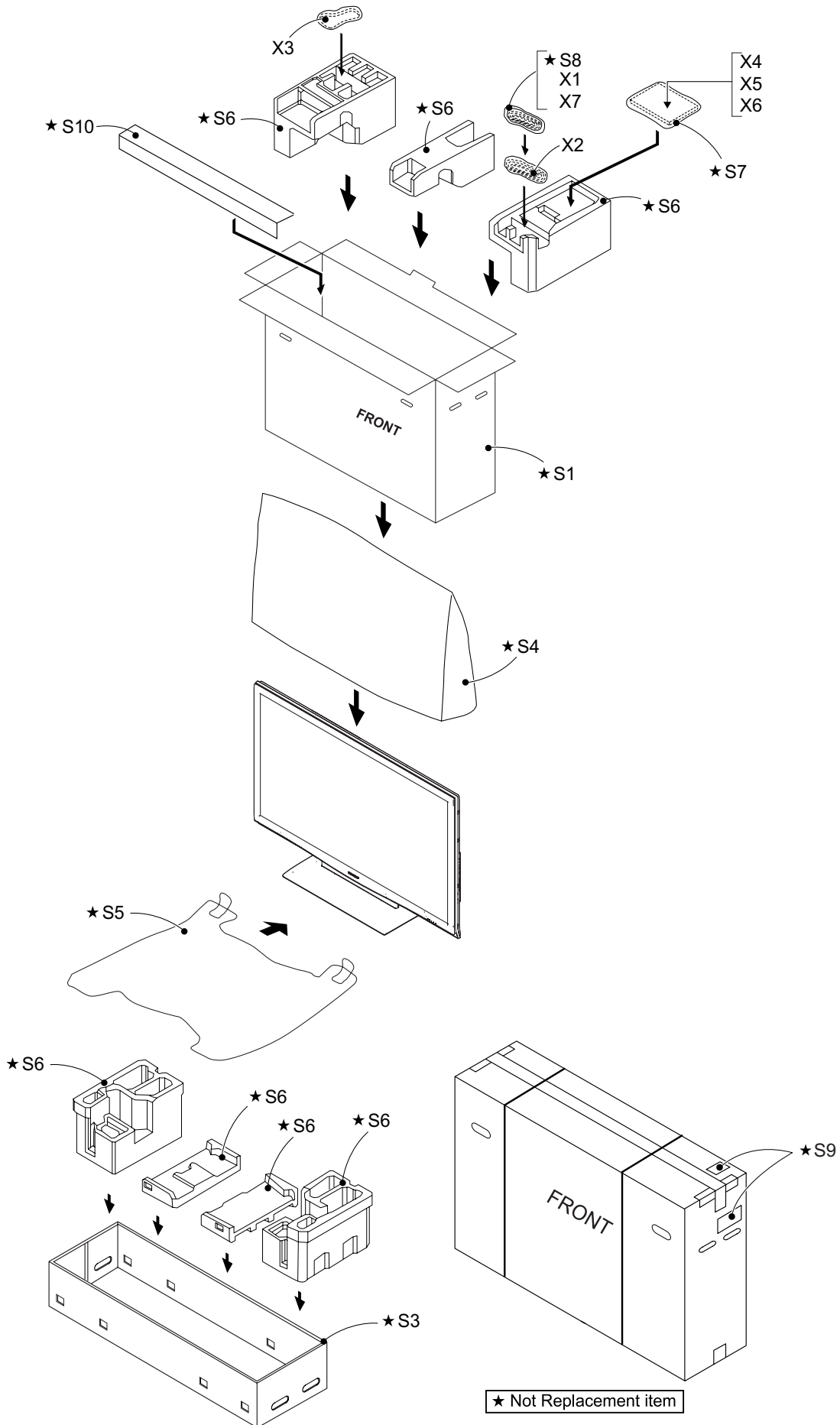

NO.	PARTS CODE	PRICE RANK	NEW MARK	PART DELIVERY	DESCRIPTION
<b>[12] PACKING PARTS (NOT REPLACEMENT ITEM)</b>					
S1	SPAKCF070WJZZ	-	N	-	Packing Case (LC-60E77UN)
S1	SPAKCF071WJZZ	-	N	-	Packing Case (LC-65E77UM)
S1	SPAKCF294WJZZ	-	N	-	Packing Case (LC-C6077UN)
S1	SPAKCF290WJZZ	-	N	-	Packing Case (LC-C6577UM)
S3	SPAKCF063WJZZ	-	N	-	Packing Case Bottom (LC-60E77UN/C6077UN)
S3	SPAKCF065WJZZ	-	N	-	Packing Case Bottom (LC-65E77UM/C6577UM)
S4	SPAKPB427WJZZ	-	N	-	Wrapping Paper (LC-60E77UN/C6077UN)
S4	SPAKPA962WJZZ	-	N	-	Wrapping Paper (LC-65E77UM/C6577UM)
S5	SPAKPB428WJZZ	-	N	-	Wrapping Paper
S6	SPAKXC634WJZZ	-	N	-	packing ADD (LC-60E77UN/C6077UN)
S6	SPAKXC635WJZZ	-	N	-	packing ADD (LC-65E77UM/C6577UM)
S7	SSAKA0101GJZZ	-	-	-	Polyethylene Bag
S8	SSAKA032WJZZ	-	-	-	Polyethylene Bag
S9	TLABKA009WJZZ	-	-	-	Case No. Label
S10	SPAKSA017WJZZ	-	-	-	C-PAD (LC-60E77UN/C6077UN)
<b>[13] SERVICE JIGS (USE FOR SERVICING)</b>					
N	QCNW-C222WJQZ	AW		J	Connecting Cord (L=1000mm 80Pins), x2
N					LCD Control - LCD Panel
N	QCNW-F676WJQZ	BH		J	Connecting Cord (L=1000mm 41Pins)
N					MAIN - LCD Control (LW)
N	QCNW-H184WJQZ	AX		J	Connecting Cord (L=1000mm 12Pins)
N					MAIN - POWER (PD)
N	QCNW-G401WJQZ	AP		J	Connecting Cord (L=1000mm 4-5Pins)
N					MAIN - KEY (KM)
N	QCNW-H762WJQZ	AV		J	Connecting Cord (L=1000mm 10Pins)
N					MAIN - R/C, LED (RA)
N	QCNW-H649WJPZ	AP		J	Connecting Cord (L=1000mm 4Pins)
N					MAIN - SPEAKER (SP)
N	QCNW-J279WJQZ	AY		J	Connecting Cord (L=1000mm 15Pins) (LC-60E77UN/C6077UN)
N					MAIN - LCD Control (LP)
N	QCNW-K277WJQZ		N	J	Connecting Cord (L=1000mm 9-10-14Pins) (LC-60E77UN/C6077UN)
N					MAIN (LB) - POWER (LA1) - INVERTER (LA)
N	QCNW-G405WJQZ	AP		J	Connecting Cord (L=1000mm 4Pins) (LC-60E77UN/C6077UN)
N					MAIN - LCD Control (PL)
N	QCNW-K077WJQZ		N	J	Connecting Cord (L=1370mm 9Pins) (LC-65E77UM/C6577UN)
N					MAIN - INVERTER (LB)
N	QCNW-H017WJQZ	AM		J	Connecting Cord (L=1000mm 3Pins) (LC-65E77UM/C6577UN)
N					MAIN POWER - SUB POWER (PP1) (PP2)
N	QCNW-H018WJQZ	AK		J	Connecting Cord (L=1000mm 2Pins) (LC-65E77UM/C6577UN)
N					MAIN POWER - SUB POWER (PP3)
N	QCNW-K276WJQZ		N	J	Connecting Cord (L=1000mm 12Pin-MAIN 15Pins/SUB POWER 4Pin (FR)) (LC-65E77UM/C6577UM)

# SHARP

**COPYRIGHT © 2009 BY SHARP CORPORATION**

ALL RIGHTS RESERVED.

No Part of this publication may be reproduced, stored in a retrieval system, or transmitted in any form or by any means, electronic, mechanical, photocopying, recording, or otherwise, without prior written permission of the publisher.